

Version : 2.0

TECHNICAL SPECIFICATION
MODEL NO. : PD057VU9

The content of this information is subject to be changed without notice.
Please contact PVI or its agent for further information.

Customer's Confirmation

Customer _____

Date _____

By _____

PVI's Confirmation

申峰坤

Confirmed By _____

吳昌霖

Prepared By _____

Revision History

Rev.	Issued Date	Eng.	Revised Contents																																				
0.1	May. 12, 2008	吳昌霖	Preliminary																																				
0.2	May. 21, 2008	吳昌霖	Delete 5-2 LED Backlight driving add Note5-5 : Connector type SM08B-SRSS-TB Modify 9.Block Diagram data · CLK · Hsync · Vsync · DE change from 15Ω to 100Ω DPSH · DPSV change from 10KΩ to 47KΩ DE pull low change from 4.7KΩ to 47KΩ Modify Note 7-2 and figure of LED light bar $P_{LED} = V_{LED1} \times I_{LED1} + V_{LED2} \times I_{LED2} + V_{LED3} \times I_{LED3} + V_{LED4} \times I_{LED4}$ Add 13-1 Luminance Uniformity 80% (Typ.) 70% (Min.)																																				
0.3	Jul. 10, 2008	吳昌霖	Modify pixel arrangement Before : <div style="border: 1px solid black; display: inline-block; padding: 2px; margin: 5px;"> <table border="1" style="border-collapse: collapse; text-align: center;"> <tr> <td style="width: 20px; height: 20px;">R</td> <td style="width: 20px; height: 20px;">G</td> <td style="width: 20px; height: 20px;">B</td> </tr> </table> </div> After : <div style="border: 1px solid black; display: inline-block; padding: 2px; margin: 5px;"> <table border="1" style="border-collapse: collapse; text-align: center;"> <tr> <td style="width: 20px; height: 20px;">B</td> <td style="width: 20px; height: 20px;">G</td> <td style="width: 20px; height: 20px;">R</td> </tr> </table> </div> Add Back Light Power Consumption---page 8 Add total Power Consumption---page 9 Add optical parameter---page 18	R	G	B	B	G	R																														
R	G	B																																					
B	G	R																																					
0.4	Nov. 17, 2008	吳昌霖	Modify 4.Mechanical Drawing of TFT-LCD Module Modify 6.Absolute Maximum Ratings Before : <p>6.Absolute Maximum Ratings: GND=0V, Ta=25°C</p> <table border="1" style="width: 100%; border-collapse: collapse; text-align: center;"> <thead> <tr> <th>Parameters</th> <th>Symbol</th> <th>Condition</th> <th>MAX.</th> <th>Unit</th> <th>Remark</th> </tr> </thead> <tbody> <tr> <td>Input Voltage</td> <td>V_i</td> <td>Ta=25°C</td> <td>-0.3~+4</td> <td>V</td> <td>Note6-1</td> </tr> <tr> <td>+3.3V supply voltage</td> <td>V_{CC}</td> <td>Ta=25°C</td> <td>0~+3.6</td> <td>V</td> <td></td> </tr> </tbody> </table> <p style="font-size: small;">Note6-1: CK, R0~R5, G0~G5, B0~B5, Hsync, Vsync, ENAB, R/L, U/D, V/Q</p> After : <p>6.Absolute Maximum Ratings: GND=0V, Ta=25°C</p> <table border="1" style="width: 100%; border-collapse: collapse; text-align: center;"> <thead> <tr> <th>Parameters</th> <th>Symbol</th> <th>Condition</th> <th>MAX.</th> <th>Unit</th> <th>Remark</th> </tr> </thead> <tbody> <tr> <td>Input Voltage</td> <td>V_i</td> <td>Ta=25°C</td> <td>-0.3 to $V_{CC}+0.3$</td> <td>V</td> <td>Note6-1</td> </tr> <tr> <td>+3.3V supply voltage</td> <td>V_{CC}</td> <td>Ta=25°C</td> <td>-0.3~+6.5</td> <td>V</td> <td></td> </tr> </tbody> </table> <p style="font-size: small;">Note6-1 : CK, R0~R5, G0~G5, B0~B5, Hsync, Vsync, ENAB, R/L, U/D, V/Q</p> Add Note 7-3 : Checkered flag pattern---page 9 Add LED life time---page 18 Add Note 13-6---page21 a. This lifetime is the estimated value, and is not guarantee value. b. The “LED Life time “ is defined as the module brightness decrease to 50% original Brightness that the ambient temperature is 25°C and $I_{LED} = 25mA$. c. Estimated luminance lifetime is not the value for LCD module but the value for LED elementary substance.	Parameters	Symbol	Condition	MAX.	Unit	Remark	Input Voltage	V_i	Ta=25°C	-0.3~+4	V	Note6-1	+3.3V supply voltage	V_{CC}	Ta=25°C	0~+3.6	V		Parameters	Symbol	Condition	MAX.	Unit	Remark	Input Voltage	V_i	Ta=25°C	-0.3 to $V_{CC}+0.3$	V	Note6-1	+3.3V supply voltage	V_{CC}	Ta=25°C	-0.3~+6.5	V	
Parameters	Symbol	Condition	MAX.	Unit	Remark																																		
Input Voltage	V_i	Ta=25°C	-0.3~+4	V	Note6-1																																		
+3.3V supply voltage	V_{CC}	Ta=25°C	0~+3.6	V																																			
Parameters	Symbol	Condition	MAX.	Unit	Remark																																		
Input Voltage	V_i	Ta=25°C	-0.3 to $V_{CC}+0.3$	V	Note6-1																																		
+3.3V supply voltage	V_{CC}	Ta=25°C	-0.3~+6.5	V																																			

Rev.	Issued Date	Eng.	Revised Contents																																																																																																								
0.5	Dec. 1, 2008	吳昌霖	<p>Modify Note 5-4</p> <p>Before :</p> <p>Note 5-4 : The following table is the coordinates per pixel :</p> <div style="text-align: center;"> <p>C(0, 0)</p> <table border="1"> <tr> <td>B</td> <td>G</td> <td>R</td> </tr> </table> </div> <table border="1"> <tr> <td>C(0, 0)</td> <td>C(1, 0)</td> <td>...</td> <td>C(X, 0)</td> <td>...</td> <td>C(638, 0)</td> <td>C(639, 0)</td> </tr> <tr> <td>C(0, 1)</td> <td>C(1, 1)</td> <td>...</td> <td>C(X, 1)</td> <td>...</td> <td>C(638, 1)</td> <td>C(639, 1)</td> </tr> <tr> <td>⋮</td> <td>⋮</td> <td>⋮</td> <td>⋮</td> <td>⋮</td> <td>⋮</td> <td>⋮</td> </tr> <tr> <td>C(0, Y)</td> <td>C(1, Y)</td> <td>...</td> <td>C(X, Y)</td> <td>...</td> <td>C(638, Y)</td> <td>C(639, Y)</td> </tr> <tr> <td>⋮</td> <td>⋮</td> <td>⋮</td> <td>⋮</td> <td>⋮</td> <td>⋮</td> <td>⋮</td> </tr> <tr> <td>C(0, 478)</td> <td>C(1, 478)</td> <td>...</td> <td>C(X, 478)</td> <td>...</td> <td>C(638, 478)</td> <td>C(639, 478)</td> </tr> <tr> <td>C(0, 479)</td> <td>C(1, 479)</td> <td>...</td> <td>C(X, 479)</td> <td>...</td> <td>C(638, 479)</td> <td>C(639, 479)</td> </tr> </table> <p>After :</p> <p>Note 5-4 : The following table is the coordinates per pixel : (refer to Note 5-3)</p> <div style="text-align: center;"> <p>C(0, 0)</p> <table border="1"> <tr> <td>R</td> <td>G</td> <td>B</td> </tr> </table> </div> <table border="1"> <tr> <td>C(0, 0)</td> <td>C(1, 0)</td> <td>...</td> <td>C(X, 0)</td> <td>...</td> <td>C(638, 0)</td> <td>C(639, 0)</td> </tr> <tr> <td>C(0, 1)</td> <td>C(1, 1)</td> <td>...</td> <td>C(X, 1)</td> <td>...</td> <td>C(638, 1)</td> <td>C(639, 1)</td> </tr> <tr> <td>⋮</td> <td>⋮</td> <td>⋮</td> <td>⋮</td> <td>⋮</td> <td>⋮</td> <td>⋮</td> </tr> <tr> <td>C(0, Y)</td> <td>C(1, Y)</td> <td>...</td> <td>C(X, Y)</td> <td>...</td> <td>C(638, Y)</td> <td>C(639, Y)</td> </tr> <tr> <td>⋮</td> <td>⋮</td> <td>⋮</td> <td>⋮</td> <td>⋮</td> <td>⋮</td> <td>⋮</td> </tr> <tr> <td>C(0, 478)</td> <td>C(1, 478)</td> <td>...</td> <td>C(X, 478)</td> <td>...</td> <td>C(638, 478)</td> <td>C(639, 478)</td> </tr> <tr> <td>C(0, 479)</td> <td>C(1, 479)</td> <td>...</td> <td>C(X, 479)</td> <td>...</td> <td>C(638, 479)</td> <td>C(639, 479)</td> </tr> </table> <p>Add LED voltage---page9 LED voltage(typ.)=29.7V Add total power consumption(typ.)=3.32W---page10</p> <p>Modify 11-3-3 Common item of Fixed mode and DE mode---page19</p> <p>Before :</p>	B	G	R	C(0, 0)	C(1, 0)	...	C(X, 0)	...	C(638, 0)	C(639, 0)	C(0, 1)	C(1, 1)	...	C(X, 1)	...	C(638, 1)	C(639, 1)	⋮	⋮	⋮	⋮	⋮	⋮	⋮	C(0, Y)	C(1, Y)	...	C(X, Y)	...	C(638, Y)	C(639, Y)	⋮	⋮	⋮	⋮	⋮	⋮	⋮	C(0, 478)	C(1, 478)	...	C(X, 478)	...	C(638, 478)	C(639, 478)	C(0, 479)	C(1, 479)	...	C(X, 479)	...	C(638, 479)	C(639, 479)	R	G	B	C(0, 0)	C(1, 0)	...	C(X, 0)	...	C(638, 0)	C(639, 0)	C(0, 1)	C(1, 1)	...	C(X, 1)	...	C(638, 1)	C(639, 1)	⋮	⋮	⋮	⋮	⋮	⋮	⋮	C(0, Y)	C(1, Y)	...	C(X, Y)	...	C(638, Y)	C(639, Y)	⋮	⋮	⋮	⋮	⋮	⋮	⋮	C(0, 478)	C(1, 478)	...	C(X, 478)	...	C(638, 478)	C(639, 478)	C(0, 479)	C(1, 479)	...	C(X, 479)	...	C(638, 479)	C(639, 479)
B	G	R																																																																																																									
C(0, 0)	C(1, 0)	...	C(X, 0)	...	C(638, 0)	C(639, 0)																																																																																																					
C(0, 1)	C(1, 1)	...	C(X, 1)	...	C(638, 1)	C(639, 1)																																																																																																					
⋮	⋮	⋮	⋮	⋮	⋮	⋮																																																																																																					
C(0, Y)	C(1, Y)	...	C(X, Y)	...	C(638, Y)	C(639, Y)																																																																																																					
⋮	⋮	⋮	⋮	⋮	⋮	⋮																																																																																																					
C(0, 478)	C(1, 478)	...	C(X, 478)	...	C(638, 478)	C(639, 478)																																																																																																					
C(0, 479)	C(1, 479)	...	C(X, 479)	...	C(638, 479)	C(639, 479)																																																																																																					
R	G	B																																																																																																									
C(0, 0)	C(1, 0)	...	C(X, 0)	...	C(638, 0)	C(639, 0)																																																																																																					
C(0, 1)	C(1, 1)	...	C(X, 1)	...	C(638, 1)	C(639, 1)																																																																																																					
⋮	⋮	⋮	⋮	⋮	⋮	⋮																																																																																																					
C(0, Y)	C(1, Y)	...	C(X, Y)	...	C(638, Y)	C(639, Y)																																																																																																					
⋮	⋮	⋮	⋮	⋮	⋮	⋮																																																																																																					
C(0, 478)	C(1, 478)	...	C(X, 478)	...	C(638, 478)	C(639, 478)																																																																																																					
C(0, 479)	C(1, 479)	...	C(X, 479)	...	C(638, 479)	C(639, 479)																																																																																																					

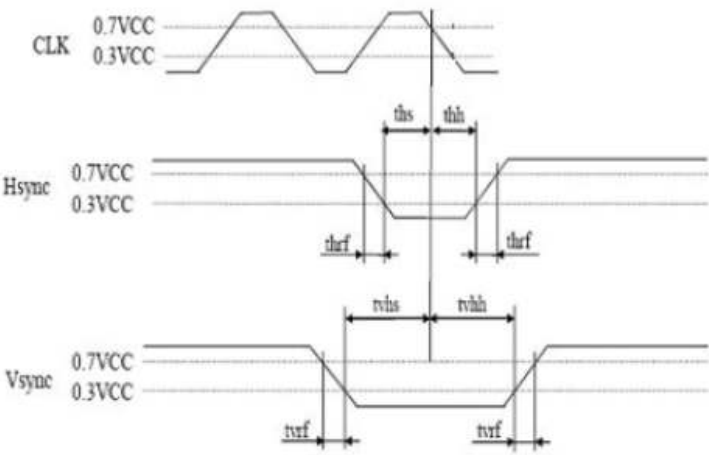
Rev.	Issued Date	Eng.	Revised	Contents
1.0	Dec. 1, 2008	吳昌霖	After :	
	Feb. 19, 2009			Modify 13. Optical Characteristics Luminance Uniformity change from 70%(min.) to 72%(min.). Modify Note 13-5 Luminance Uniformity define from 9 point to 5 point Delete Cross talk specifications Delete Note 13-7 Cross talk definition
2.0	May. 21, 2010	吳昌霖	Revise Packing Drawing	

TECHNICAL SPECIFICATION

CONTENTS

NO.	ITEM	PAGE
-	Cover	1
-	Revision History	2
-	Contents	5
1	Application	6
2	Features	6
3	Mechanical Specifications	6
4	Mechanical Drawing of TFT-LCD module	7
5	Input / Output Terminals	8
6	Absolute Maximum Ratings	10
7	Electrical Characteristics	10
8	Pixel Arrangement	11
9	Block Diagram	12
10	Display Color and Gray Scale Reference	13
11	Interface Timing	14
12	Power On Sequence	20
13	Optical Characteristics	20
14	Handling Cautions	24
15	Reliability Test	25
16	Packing Diagram	26

1. Application

This data sheet applies to a color TFT LCD module, PD057VU9.

PD057VU9 module applies to industrial use (must use Analog to Digital driving board), which requires high quality flat panel display. If you must use in severe reliability environment, please don't extend over PVI's reliability test conditions.

2. Features

- . VGA (640*480 pixels) resolution
- . Amorphous silicon TFT LCD panel with LED backlight
- . Pixel in stripe configuration
- . Thin and light weight
- . High contrast
- . High brightness
- . Display Colors : 262,144 colors
- . TTL interface

3. Mechanical Specifications

Parameter	Specifications	Unit
Screen Size	5.7 (diagonal)	inch
Display Format	640×(R,G,B)×480	dot
Display Colors	262,144	
Active Area	116.16 (H)×87.12 (V)	mm
Pixel Pitch	0.1815(H)×0.1815(V)	mm
Pixel Configuration	Stripe	
Outline Dimension	135.0 (W)×104.6(H)×10.4 (D) (typ.)	mm
Weight	162±10	g
Back-light	36-LED	
Surface treatment	Hard Coating + EWV film Pencil Hardness : 3H	
Display mode	Normally white	
Gray scale inversion direction	6 o'clock (ref to Note13-1)	

5. Input / Output Terminals

5-1) TFT-LCD Panel Driving

Connector type : Kyocera Elco corp. 08-6260-033-340-829+ · PIN No 33 pins

Pin No	Symbol	Description	Remark
1	GND	GND	Note 5-1
2	CLK	Dot Clock	
3	Hsync	Horizontal synchronous signal	
4	Vsync	Vertical synchronous signal	
5	GND	GND	Note 5-1
6	R0	RED data signal (LSB)	Least signification bit
7	R1	RED data signal	
8	R2	RED data signal	
9	R3	RED data signal	
10	R4	RED data signal	
11	R5	RED data signal (MSB)	Most signification bit
12	GND	GND	Note 5-1
13	G0	GREEN data signal (LSB)	Least signification bit
14	G1	GREEN data signal	
15	G2	GREEN data signal	
16	G3	GREEN data signal	
17	G4	GREEN data signal	
18	G5	GREEN data signal (MSB)	Most signification bit
19	GND	GND	Note 5-1
20	B0	Blue data signal (LSB)	Least signification bit
21	B1	Blue data signal	
22	B2	Blue data signal	
23	B3	Blue data signal	
24	B4	Blue data signal	
25	B5	Blue data signal (MSB)	Most signification bit
26	GND	GND	Note 5-1
27	DE	Selection of DE / Fixed mode	Low or Open : Fixed mode Data enable signal : DE mode Note 5-2
28	V _{CC}	+3.3V power supply	Note 5-1
29	V _{CC}	+3.3V power supply	
30	DPSH	Selection of Horizontal scan direction	High : Reverse scan Low or Open : Normal scan Note 5-3
31	DPSV	Selection of Vertical scan direction	High or Open : Normal scan Low : Reverse scan Note 5-3
32	N.C.	---	Keep this pin Open
33	GND	GND	Note 5-1

Note 5-1 : All GND and VCC terminals should be used without any non-connected lines.

Note 5-2 :

The horizontal display start timing is settled in accordance with rising of DE signal. In case DE is fixed "Low". Don't keep DE "High" during operation.

Note 5-3 : The definitions of DPSH & DPSV

Meaning of C(X,Y) and D(X,Y)

C(X,Y) : The coordinates of the display position (ref to Note 5-4)

D(X,Y) : The data number of input signal for LCD panel signal processing board

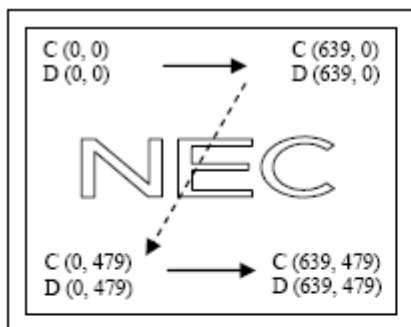

Figure1. DPSH=Low or Open (Normal scan)

DPSV=High or Open (Normal scan)

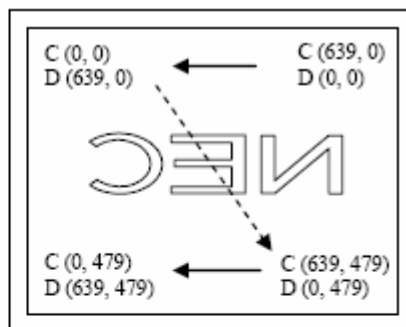

Figure2. DPSH=High (Reverse scan)

DPSV=High or Open (Normal scan)

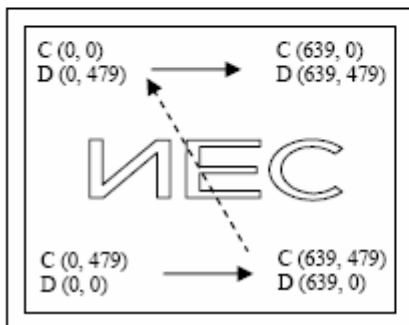

Figure3. DPSH=Low or Open (Normal scan)

DPSV=Low (Reverse scan)

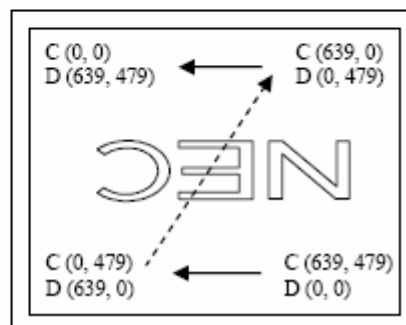

Figure4. DPSH=High (Reverse scan)

DPSV=Low (Reverse scan)

Note 5-4 : The following table is the coordinates per pixel : (refer to Note 5-3)

C(0,0)						
R	G	B				
C(0, 0)	C(1, 0)	. . .	C(X, 0)	. . .	C(638, 0)	C(639, 0)
C(0, 1)	C(1, 1)	. . .	C(X, 1)	. . .	C(638, 1)	C(639, 1)
.
.
.
C(0, Y)	C(1, Y)	. . .	C(X, Y)	. . .	C(638, Y)	C(639, Y)
.
.
.
C(0, 478)	C(1, 478)	. . .	C(X, 478)	. . .	C(638, 478)	C(639, 478)
C(0, 479)	C(1, 479)	. . .	C(X, 479)	. . .	C(638, 479)	C(639, 479)

Note 5-5 : Connector type SM08B-SRSS-TB

6.Absolute Maximum Ratings:

GND=0V, Ta=25°C

Parameters	Symbol	Condition	MAX.	Unit	Remark
Input Voltage	V_i	Ta=25°C	-0.3 to $V_{CC}+0.3$	V	Note6-1
+3.3V supply voltage	V_{CC}	Ta=25°C	-0.3~+6.5	V	
Storage temperature	Tst	-	-40~+80	°C	
Operating temperature	Top	-	-30~+80	°C	

Note6-1:CK,R0~R5,G0~G5,B0~B5,Hsync,Vsync,ENAB,R/L,U/D,V/Q

7.Electrical Characteristics

7-1) Recommended Operating Conditions:

GND=0V, Ta=25°C

Item	Symbol	Min.	Typ.	Max.	Unit	Remark
+3.3V Supply Voltage	V_{CC}	+3.0	+3.3	+3.6	V	
Permissive input ripple voltage	V_{RF}	-	-	100	mVp-p	$V_{CC}=3.3V$
Input voltage(Low)	V_{IL}	0	-	0.3 V_{CC}	V	
Input voltage(High)	V_{IH}	0.7 V_{CC}	-	V_{CC}	V	

7-2) Recommended Driving Condition for LED Back Light

Ta=25°C

Parameter	Symbol	Min.	Typ.	Max.	Unit	Remark
LED voltage	V_{LED}	-	29.7	(34.2)	V	$I_{LED}= 25mA$
LED current	I_{LED}	-	25	-	mA	Note 7-1
Back Light Power Consumption	P_{LED}	-	2.97	3.42	mW	Note 7-2

Note 7-1 : The LED driving condition is defined for each LED module. (9 LED Serial)

Note 7-2 : $P_{LED} = V_{LED1} \times I_{LED1} + V_{LED2} \times I_{LED2} + V_{LED3} \times I_{LED3} + V_{LED4} \times I_{LED4}$

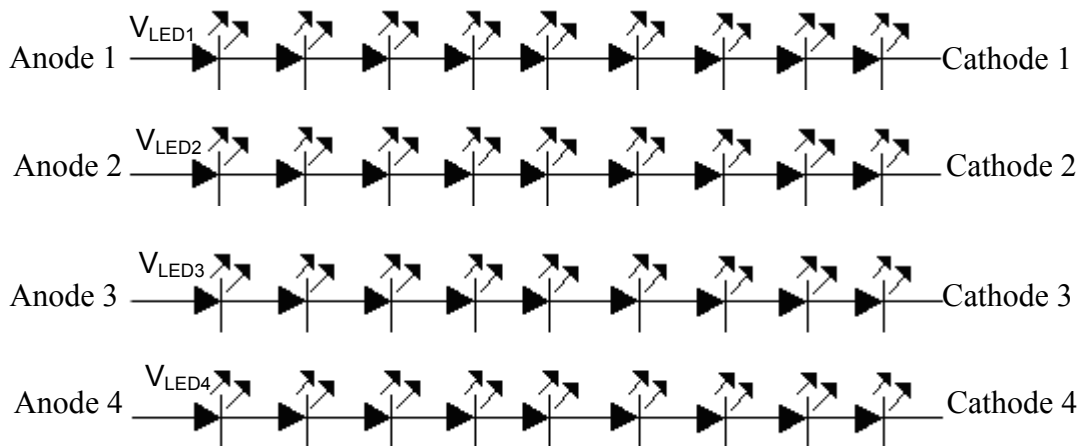

7-3) Power Consumption

Parameters	Symbol	Typ.	Max.	Unit	Remark
+3.3V Current Dissipation	I _{CC}	106 (Note 7-3)	159	mA	
LCD Panel Power Consumption	-	0.35	0.52	W	Note 7-4
Total Power Consumption	-	3.32	3.94	W	

Note 7-3 : Checkered flag pattern

Note 7-4 : The power consumption for back light is not included.

8. Pixel Arrangement

The LCD module pixel arrangement is stripe configuration.

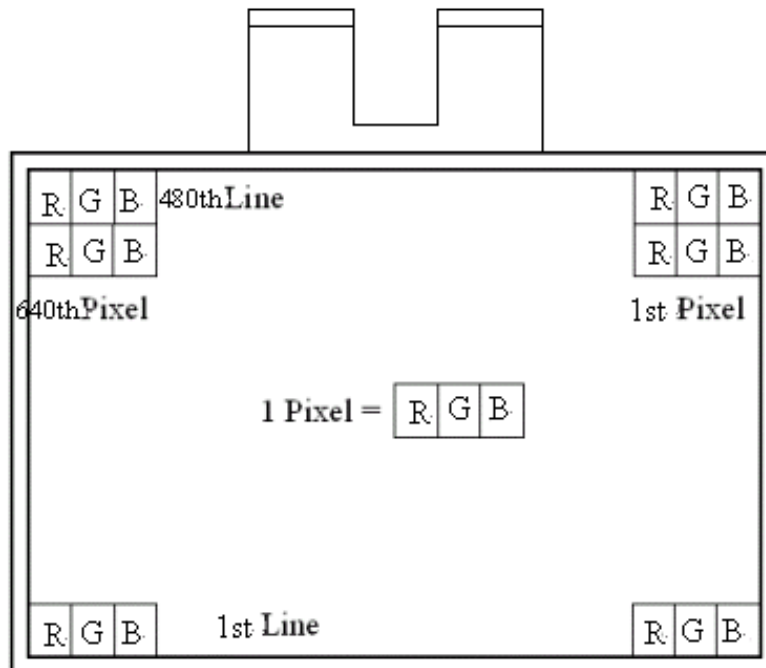

9. Block Diagram

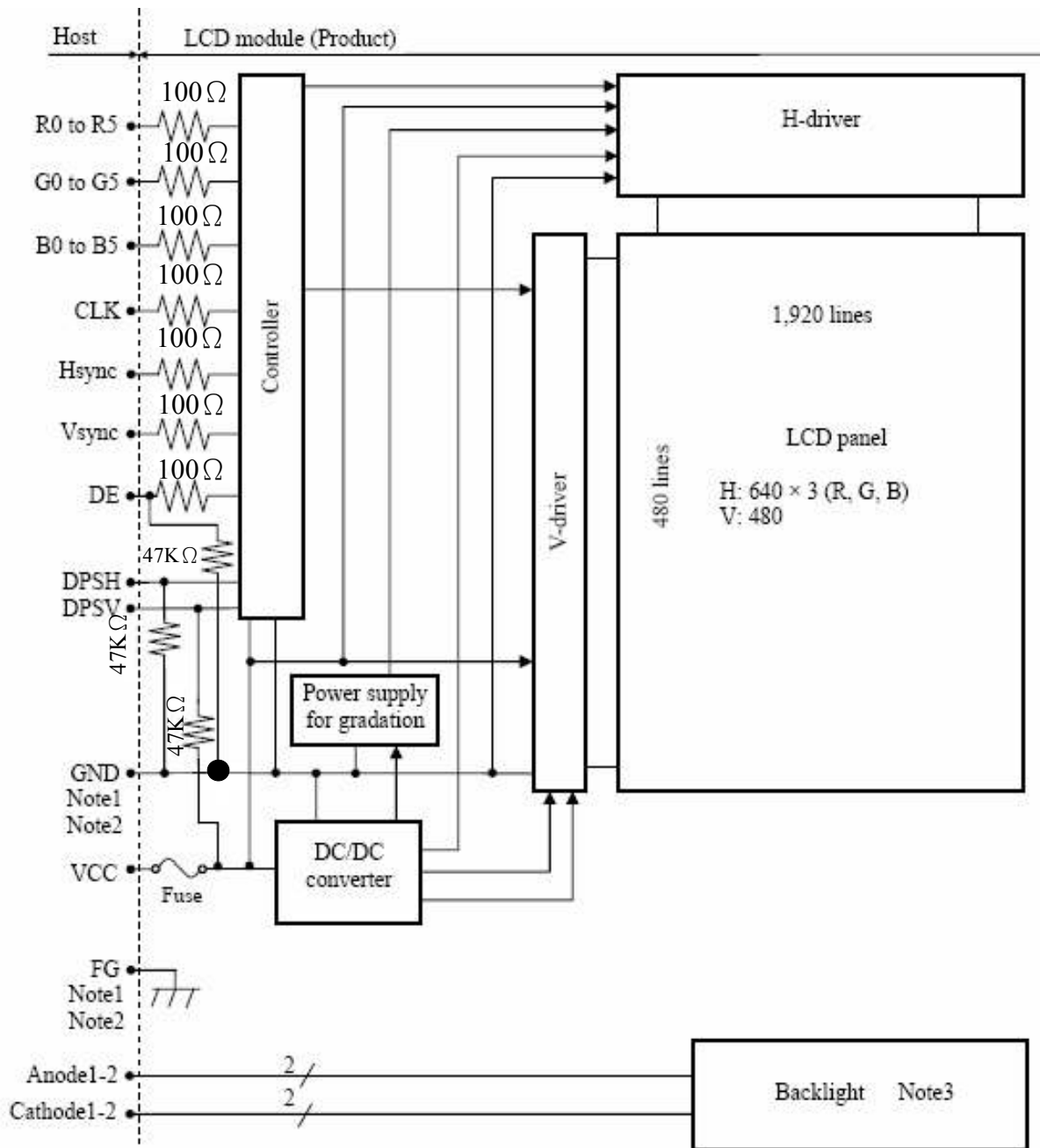

10. Display Color and Gray Scale Reference

Color		Input Color Data																	
		Red						Green						Blue					
		R5	R4	R3	R2	R1	R0	G5	G4	G3	G2	G1	G0	B5	B4	B3	B2	B1	B0
Basic Colors	Black	0	0	0	0	0	0	0	0	0	0	0	0	0	0	0	0	0	0
	Red (63)	1	1	1	1	1	1	0	0	0	0	0	0	0	0	0	0	0	0
	Green (63)	0	0	0	0	0	0	1	1	1	1	1	1	0	0	0	0	0	0
	Blue (63)	0	0	0	0	0	0	0	0	0	0	0	0	1	1	1	1	1	1
	Cyan	0	0	0	0	0	0	1	1	1	1	1	1	1	1	1	1	1	1
	Magenta	1	1	1	1	1	1	0	0	0	0	0	0	1	1	1	1	1	1
	Yellow	1	1	1	1	1	1	1	1	1	1	1	1	0	0	0	0	0	0
	White	1	1	1	1	1	1	1	1	1	1	1	1	1	1	1	1	1	1
Red	Red (00)	0	0	0	0	0	0	0	0	0	0	0	0	0	0	0	0	0	0
	Red (01)	0	0	0	0	0	1	0	0	0	0	0	0	0	0	0	0	0	0
	Red (02)	0	0	0	0	1	0	0	0	0	0	0	0	0	0	0	0	0	0
	Darker																		
	↓	↓	↓	↓	↓	↓	↓	↓	↓	↓	↓	↓	↓	↓	↓	↓	↓	↓	↓
	Brighter																		
	Red (61)	1	1	1	1	0	1	0	0	0	0	0	0	0	0	0	0	0	0
	Red (62)	1	1	1	1	1	0	0	0	0	0	0	0	0	0	0	0	0	0
	Red (63)	1	1	1	1	1	1	0	0	0	0	0	0	0	0	0	0	0	0
Green	Green (00)	0	0	0	0	0	0	0	0	0	0	0	0	0	0	0	0	0	0
	Green (01)	0	0	0	0	0	0	0	0	0	0	0	1	0	0	0	0	0	0
	Green (02)	0	0	0	0	0	0	0	0	0	0	1	0	0	0	0	0	0	0
	Darker																		
	↓	↓	↓	↓	↓	↓	↓	↓	↓	↓	↓	↓	↓	↓	↓	↓	↓	↓	↓
	Brighter																		
	Green (61)	0	0	0	0	0	0	1	1	1	1	0	1	0	0	0	0	0	0
	Green (62)	0	0	0	0	0	0	1	1	1	1	1	0	0	0	0	0	0	0
	Green (63)	0	0	0	0	0	0	1	1	1	1	1	1	0	0	0	0	0	0
Blue	Blue (00)	0	0	0	0	0	0	0	0	0	0	0	0	0	0	0	0	0	0
	Blue (01)	0	0	0	0	0	0	0	0	0	0	0	0	0	0	0	0	0	1
	Blue (02)	0	0	0	0	0	0	0	0	0	0	0	0	0	0	0	0	1	0
	Darker																		
	↓	↓	↓	↓	↓	↓	↓	↓	↓	↓	↓	↓	↓	↓	↓	↓	↓	↓	↓
	Brighter																		
	Blue (61)	0	0	0	0	0	0	0	0	0	0	0	0	1	1	1	1	0	1
	Blue (62)	0	0	0	0	0	0	0	0	0	0	0	0	1	1	1	1	1	0
	Blue (63)	0	0	0	0	0	0	0	0	0	0	0	0	1	1	1	1	1	1

11. Interface Timing

11-1) Timing Parameters

11-1-1 Fixed mode :

Parameter		Symbol	min.	typ.	max.	Unit	Remarks		
CLK	Frequency	1/tc	22.66	25.175	27.69	MHz	39.72ns (typ.)		
	Duty	tcd	0.4	0.5	0.6	-	-		
	Rise time, Fall time	terf	-	-	10	ns			
DATA (R0-R5) (G0-G5) (B0-B5)	CLK-DATA	Setup time	tds	10	-	-	ns	-	
		Hold time	tdh	10	-	-	ns		
	Rise time, Fall time	tdrf	-	-	10	ns			
Hsync	Cycle	th	30.0	31.778	33.6	μs	31.468kHz (typ.)		
			800			CLK	-		
	Display period	thd	640			CLK			
	Front-porch	thf	16			CLK			
	Pulse width	thp	10	96	-	CLK			
	Back-porch	thb	-	48	134	CLK			
	Total of pulse width and back-porch	thp + thb	144			CLK			
	CLK- Hsync	Setup time	ths	10	-	-		ns	-
		Hold time	thh	10	-	-		ns	
	Rise time, Fall time	thrf	-	-	10	ns			
Vsync	Cycle	tv	16.1	16.683	17.2	ms		59.94Hz (typ.)	
			525			H	-		
	Display period	tvd	480			H			
	Front-porch	tvf	12			H			
	Pulse width	tvp	1	3	-	H			
	Back-porch	tvb	-	32	34	H			
	Total of pulse width and back-porch	tvp + tvb	35			H			
	Hsync-Vsync	Setup time	tvhs	10	-	-		ns	-
		Hold time	tvhh	10	-	-		ns	
Rise time, Fall time	tvrf	-	-	10	ns				

Note 11-1 : Definition of parameters is as follows.

$$tc = 1\text{CLK}, tcd = tch/tc, th = 1H$$

Note 11-2 : Keep tvp + tvb and thp + thb within the table

11-1-2 DE mode :

Parameter		Symbol	min.	typ.	max.	Unit	Remarks	
CLK	Frequency	1/tc	22.66	25.175	27.69	MHz	39.72ns (typ.)	
	Duty	tcd	0.4	0.5	0.6	-	-	
	Rise time, Fall time	tcrf	-	-	10	ns	-	
DATA (R0-R5) (G0-G5) (B0-B5)	CLK-DATA	Setup time	tds	10	-	-	ns	-
		Hold time	tdh	10	-	-	ns	
	Rise time, Fall time	tdrf	-	-	10	ns		
DE	Horizontal	Cycle	th	30.0	31.778	33.6	μs	31.468kHz (typ.)
			-	800	-	CLK	-	
		Display period	thd	640			CLK	-
	Vertical (One frame)	Cycle	tv	16.1	16.683	17.2	ms	59.94Hz (typ.)
			-	525	-	H	-	
		Display period	tvd	480			H	-
	CLK-DE	Setup time	tdes	10	-	-	ns	-
		Hold time	tdeh	10	-	-	ns	
		Rise time, Fall time	tderf	-	-	10	ns	

Note 11-3 : Definition of parameters is as follows.

$t_c = 1\text{CLK}$, $t_{cd} = t_{ch}/t_c$, $t_h = 1H$

Note 11-4 : Hsync signal (CN1-Pin No.3) and Vsync signal (CN1-Pin No.4) are not used inside the product at DE mode, but do not keep these pins open to avoid noise problem.

Note 11-5 : Vertical cycle (tv) should be specified in integral multiple of Horizontal cycle (th).

11-2) Outline of input signal timings

●Horizontal signal

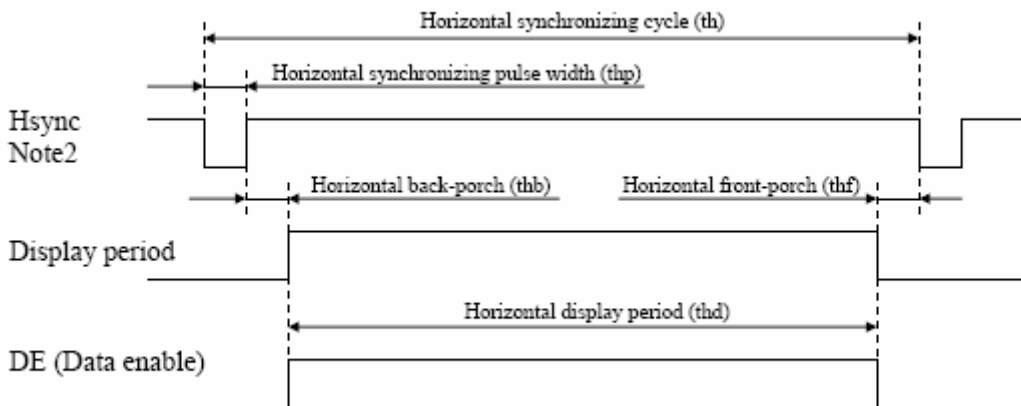

●Vertical signal

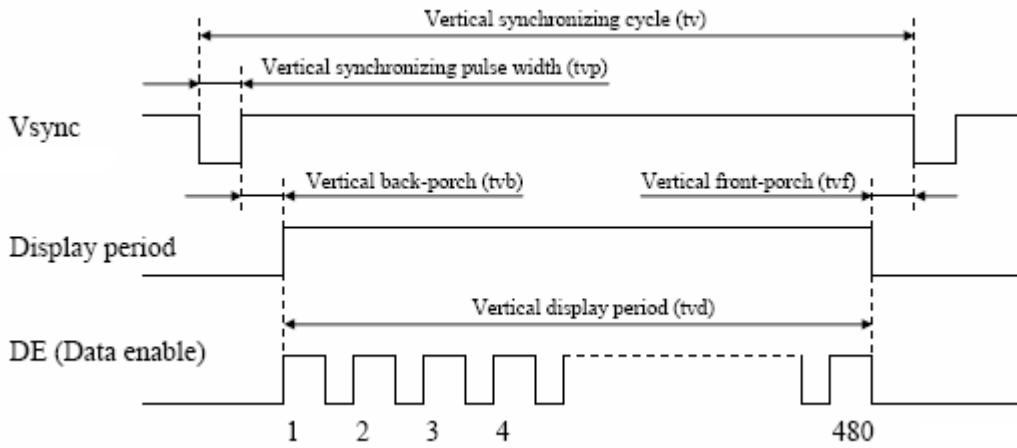

Note 11-6 : This diagram indicates virtual signal for set up to timing.

Note 11-7 : Fixed mode cannot be used while working of DE mode.

11-3) Input signal timing chart

11-3-1 Fixed mode :

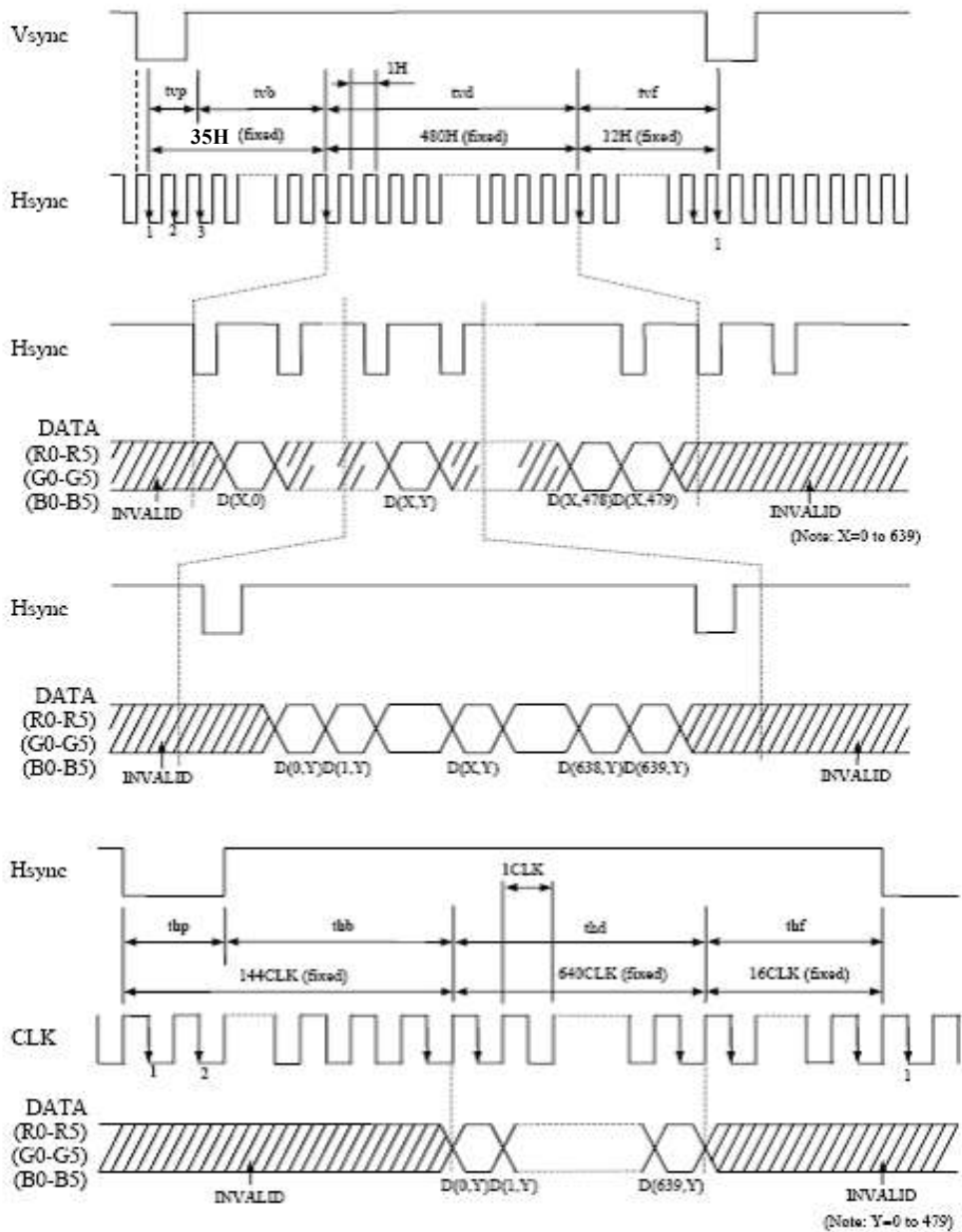

11-3-2 DE mode :

Horizontal timing

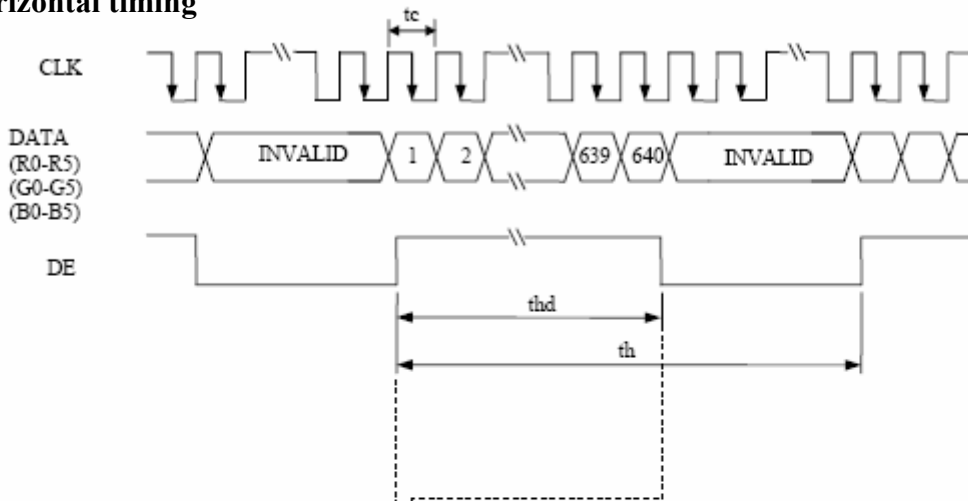

Vertical timing

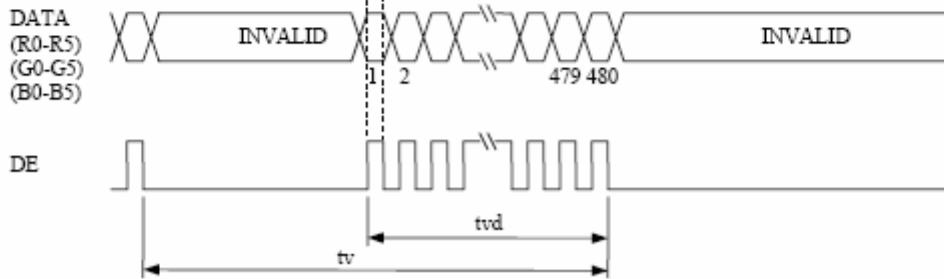

11-3-3 Common item of Fixed mode and DE mode :

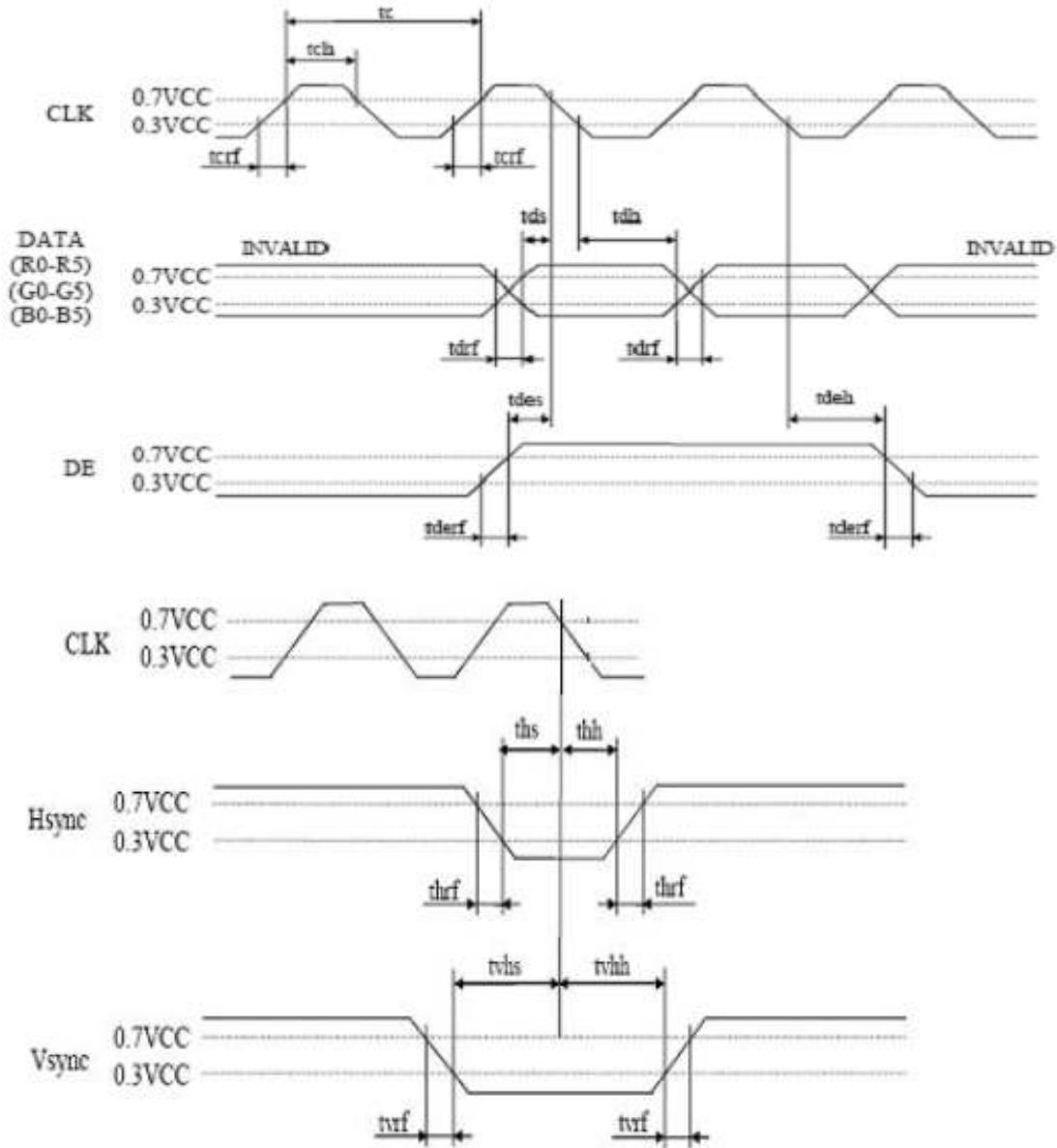

12. Power On Sequence

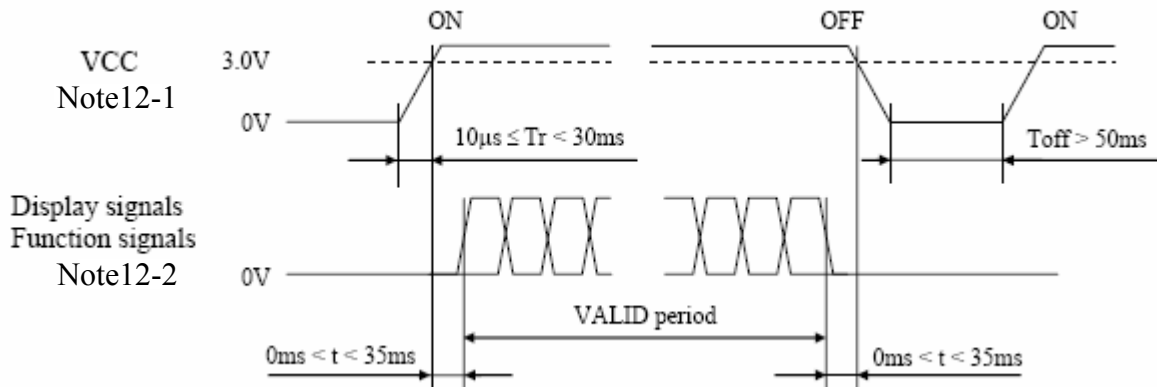

Note12-1 : In terms of voltage variation (voltage drop) while VCC rising edge is below 3.0V, a protection circuit may work, and then this product may not work.

Note12-2 : Display signals (CLK, Hsync, Vsync, DE, DATA (R0 to R5, G0 to G5, B0 to B5)) and function signals (DPSH, DPSV) must be Low or High-impedance, exclude the VALID period (See above sequence diagram), in order to avoid that internal circuits is damaged. If some of display and function signals of this product are cut while this product is working, even if the signal input to it once again, it might not work normally. VCC should be cut when the display and function signals are stopped.

13. Optical Characteristics

13-1) Specification:

Ta=25°C

Parameter		Symbol	Condition	MIN.	TYP.	MAX.	Unit	Remarks
Viewing Angle	Horizontal	θ	CR \geq 10	70	80	-	deg	Note 13-1
	Vertical	θ (to 6 o'clock)		70	80	-	deg	
		θ (to 12 o'clock)		70	80	-	deg	
Contrast Ratio		CR	At optimized viewing angle	550	850	-	-	Note 13-2
Response time	Rise	Tr	$\theta = 0^\circ$	-	3	5	ms	Note 13-3
	Fall	Tf		-	15	21		
Brightness		-	$\theta = 0^\circ / \varphi = 0$	600	800	-	cd/m ²	Note 13-4
Luminance Uniformity		U%		72	80	-	%	Note 13-5
White Chromaticity		x		0.25	0.30	0.35	-	
		y		0.30	0.35	0.40	-	
LED Life Time		-		50000	-	-	hrs	Note 13-6

Note 13-1 : The definitions of viewing angles are as follow

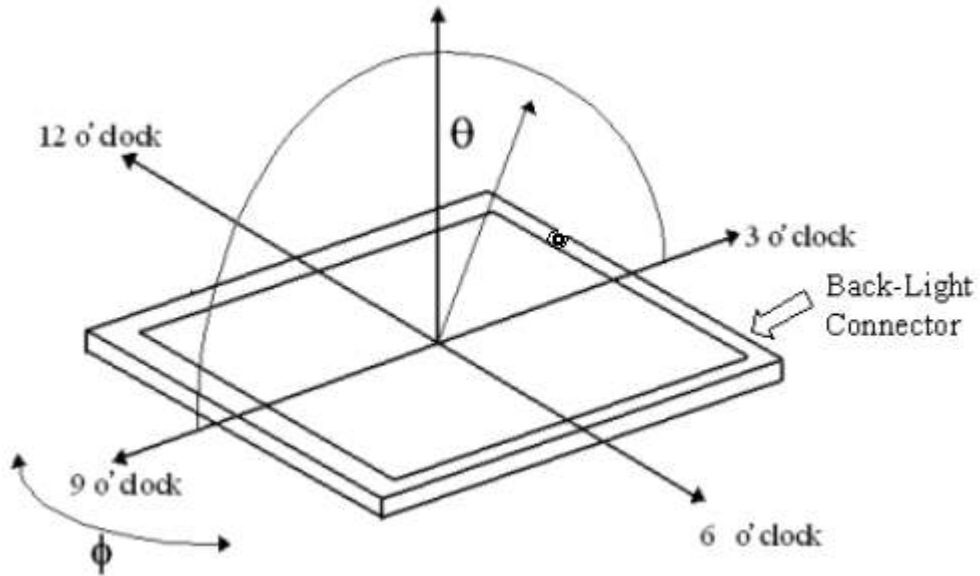

Note 13-2 : The definition of contrast ratio $CR = \frac{\text{Luminance at White Pattern}}{\text{Luminance at Black Pattern}}$

Note 13-3 : Definition of Response Time T_r and T_f :

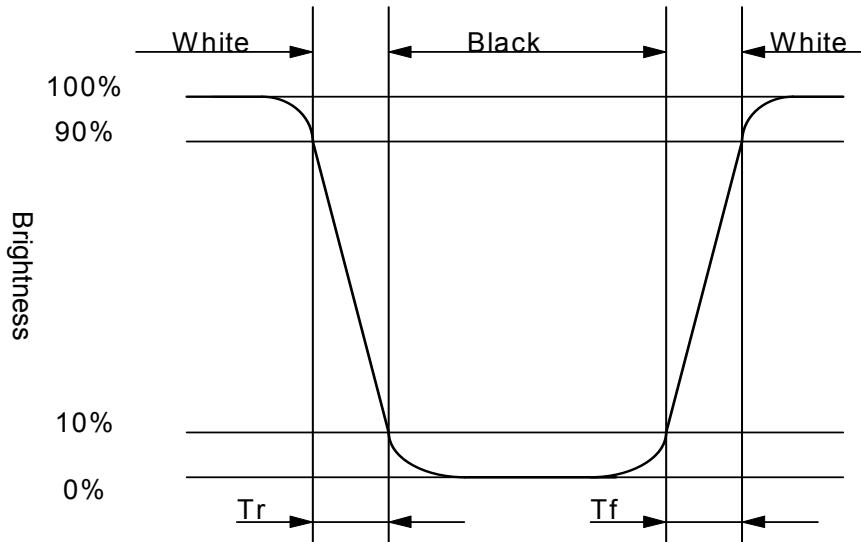

Note 13-4 : All optical measurements shall be performed after backlight being turned-on for 30 mins. The optical characteristics shall be measured in dark room (ambient illumination on panel surface less than 1 Lux). The measuring configuration shows as following figure.

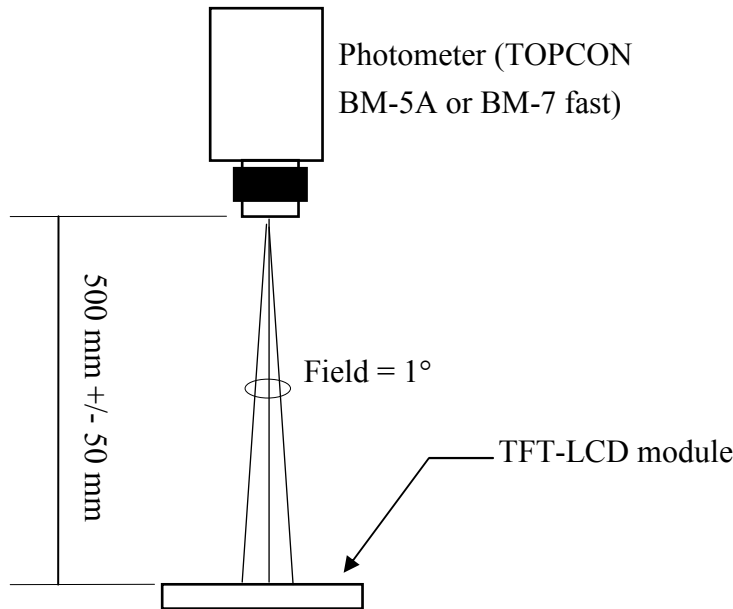

Optical characteristics measuring configuration

Note 13-5 : The uniformity of LCD is defined as

$$U = \frac{\text{The Minimum Brightness of the 5 testing Points}}{\text{The Maximum Brightness of the 5 testing Points}}$$

Luminance meter: BM-5A or BM-7 fast (TOPCON)

Measurement distance: 500 mm +/- 50 mm

Ambient illumination: < 1 Lux

Measuring direction: Perpendicular to the surface of module

The test pattern is white

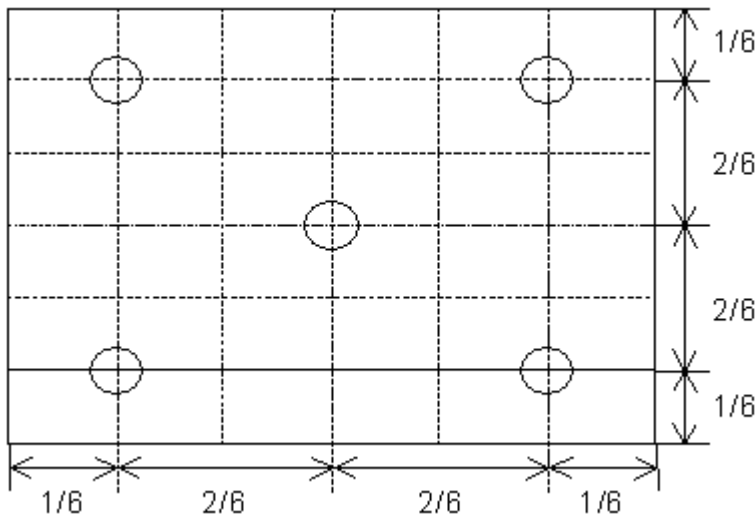

Note 13-6 :

- a. This lifetime is the estimated value, and is not guarantee value.
- b. The “LED Life time “ is defined as the module brightness decrease to 50% original Brightness that the ambient temperature is 25°C and $I_{LED} = 25mA$.
- c. Estimated luminance lifetime is not the value for LCD module but the value for LED elementary substance.

14. Handling Cautions

14-1) Mounting of module

- a) Please power off the module when you connect the input/output connector.
- b) Polarizer which is made of soft material and susceptible to flaw must be handled carefully.
- c) Protective film (Laminator) is applied on surface to protect it against scratches and dirt.
- d) Please follow the tear off direction as figure 14-1 to remove the protective film as slowly as possible, so that electrostatic charge can be minimized.

14-2) Precautions in mounting

- a) When metal part of the TFT-LCD module (shielding lid and rear case) is soiled, wipe it with soft dry cloth.
- b) Wipe off water drops or finger grease immediately. Long contact with water may cause discoloration or spots.
- c) TFT-LCD module uses glass which breaks or cracks easily if dropped or bumped on hard surface. Please handle with care.
- d) Since CMOS LSI is used in the module. So take care of static electricity and earth yourself when handling.

14-3) Adjusting module

- a) Adjusting volumes on the rear face of the module have been set optimally before shipment.
- b) Therefore, do not change any adjusted values. If adjusted values are changed, the specifications described may not be satisfied.

14-4) Others

- a) Do not expose the module to direct sunlight or intensive ultraviolet rays for many hours.
- b) Store the module at a room temperature place.
- c) The voltage of beginning electric discharge may over the normal voltage because of leakage current from approach conductor by to draw lump read lead line around.
- d) If LCD panel breaks, it is possibly that the liquid crystal escapes from the panel. Avoid putting it into eyes or mouth. When liquid crystal sticks on hands, clothes or feet. Wash it out immediately with soap.
- e) Observe all other precautionary requirements in handling general electronic components.
- f) Please adjust the voltage of common electrode as material of attachment by 1 module.

14-5) Polarizer mark

The polarizer mark is to describe the direction of wide view angle film how to match up with the rubbing direction.

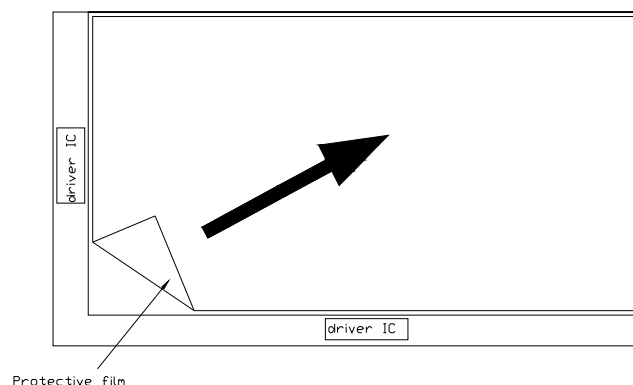

Figure 14-1 the way to peel off protective film

15. Reliability Test

No	Test Item	Test Condition	Remark
1	High Temperature Operation Test	Ta = +80°C, 240 hrs Display data is black.	No display malfunctions
2	High Temperature & High Humidity Operation Test	Ta = +60°C, 90%RH, 500 hrs Display data is black.	
3	Heat Cycling Test (operating)	-30°C → +80°C, 50 Cycles, 4hours/cycle 1 hour 1 hour Display data is black.	
4	Thermal Cycling Test (non-operating)	-40°C → +80°C, 100 Cycles, 1hour/cycle 30 min 30 min Temperature transition time is within 5 minutes.	
5	Electrostatic Discharge Test (non-operating)	150pF · 150Ω ±10KV 10 times/point 1 sec interval 9 points/panel face	
6	Vibration Test (non-operating)	5~100Hz, 19.6m/s ² 1minute/cycle X, Y, Z directions 120 times each directions	No display malfunctions No physical damages
7	Shock Test (non-operating)	Gravity : 539m/s ² * 11ms Direction: ±X, ±Y, ±Z 5 times for each direction	

Ta: ambient temperature

Note: The protective film must be removed before temperature test

[Criteria]

In the standard conditions, there is not display function NG issue occurred. (Including : line defect, no image) All the cosmetic specification is judged before the reliability stress.

16. Packing Diagram

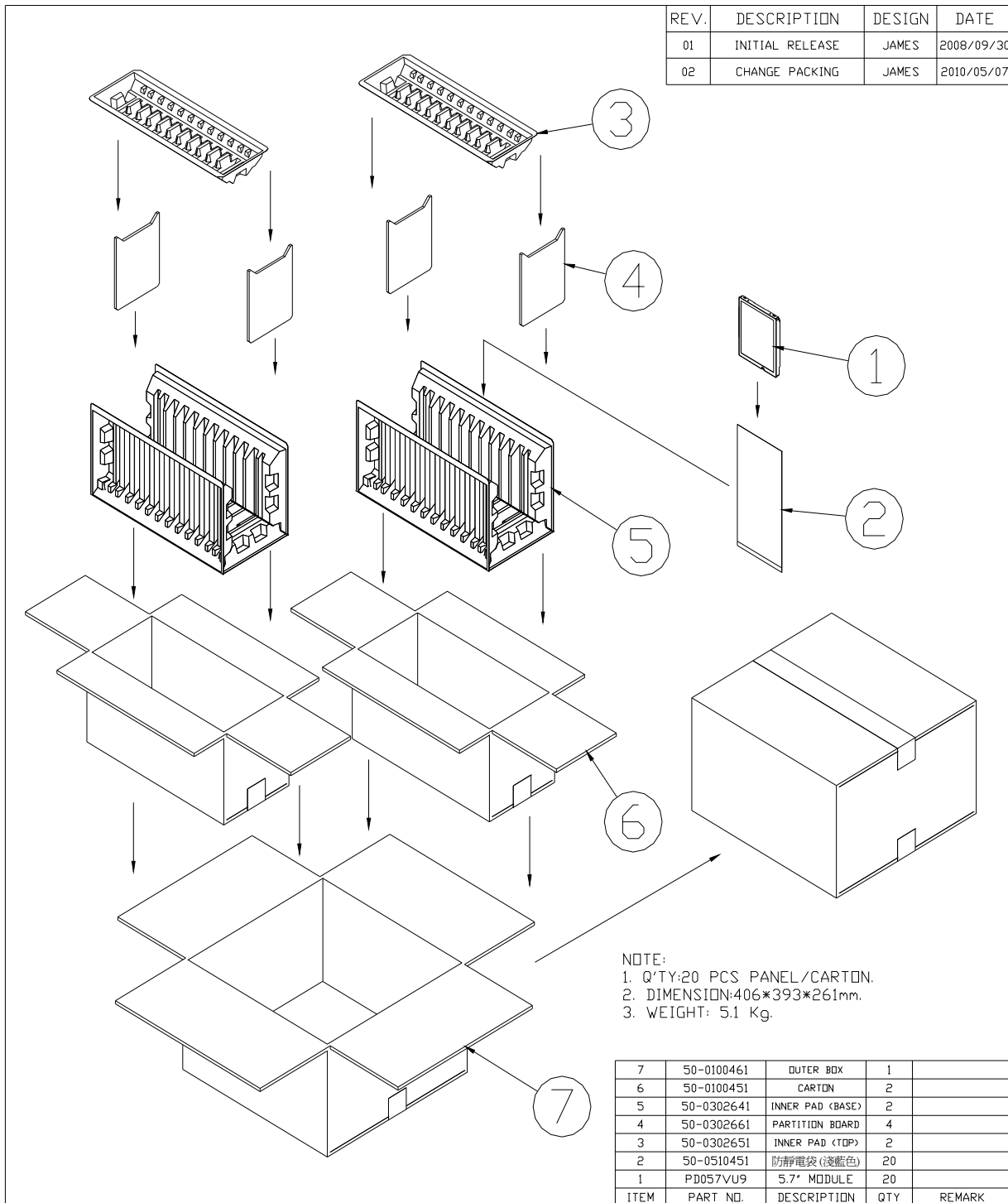

NOTE:
 1. Q'TY:20 PCS PANEL/CARTON.
 2. DIMENSION:406*393*261mm.
 3. WEIGHT: 5.1 Kg.

ITEM	PART NO.	DESCRIPTION	QTY	REMARK
7	50-0100461	OUTER BOX	1	
6	50-0100451	CARTON	2	
5	50-0302641	INNER PAD (BASE)	2	
4	50-0302661	PARTITION BOARD	4	
3	50-0302651	INNER PAD (TOP)	2	
2	50-0510451	防静电袋 (浅蓝色)	20	
1	PD057VU9	5.7" MODULE	20	

MTL.SPEC.		UNSPECIFIED TOL. ANGLE ROUGHNESS		REMARK		元太科技股份有限公司 Prime View International Co.,Ltd.	
APPROVE	PATRICK LIN	SCALE	UNIT	SHEET	DWG.TITLE		
CHECK	PATRICK LIN			1 OF 1	5.7"MODULE FOR NEC PACKING DRAW		
DESIGN	JAMES	MTL.NO. PD057VU9			DWG.NO.		REV. A4 02 SIZE