

AZ DISPLAYS, INC.

SPECIFICATIONS FOR LIQUID CRYSTAL DISPLAY

PART NUMBER:

AGM1264K

DATE:

July 12, 2005

AZ DISPLAYS, INC.

1.0 INTRODUCTION

This document specifies the outside dimensions, optical characteristics, electrical characteristics, interface, controller commands, etc. of the LCD module.

1.1 FEATURES

- (1) Compact integral COG display module
- (2) Low power consumption.
- (3) 128x164 dots FSTN LCD module.
- (4) Positive Transflective mode
- (5) S6B0724 controller /driver

2.0 CLASSIFICATION OF MODULE

AGM 1264K

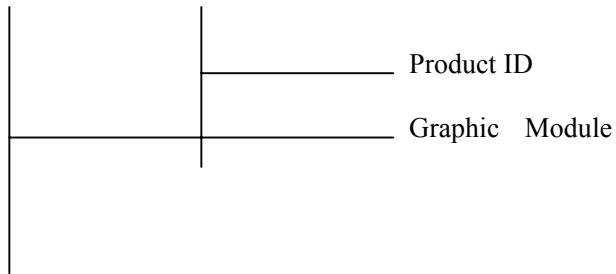

3.0 Dimensional Diagram

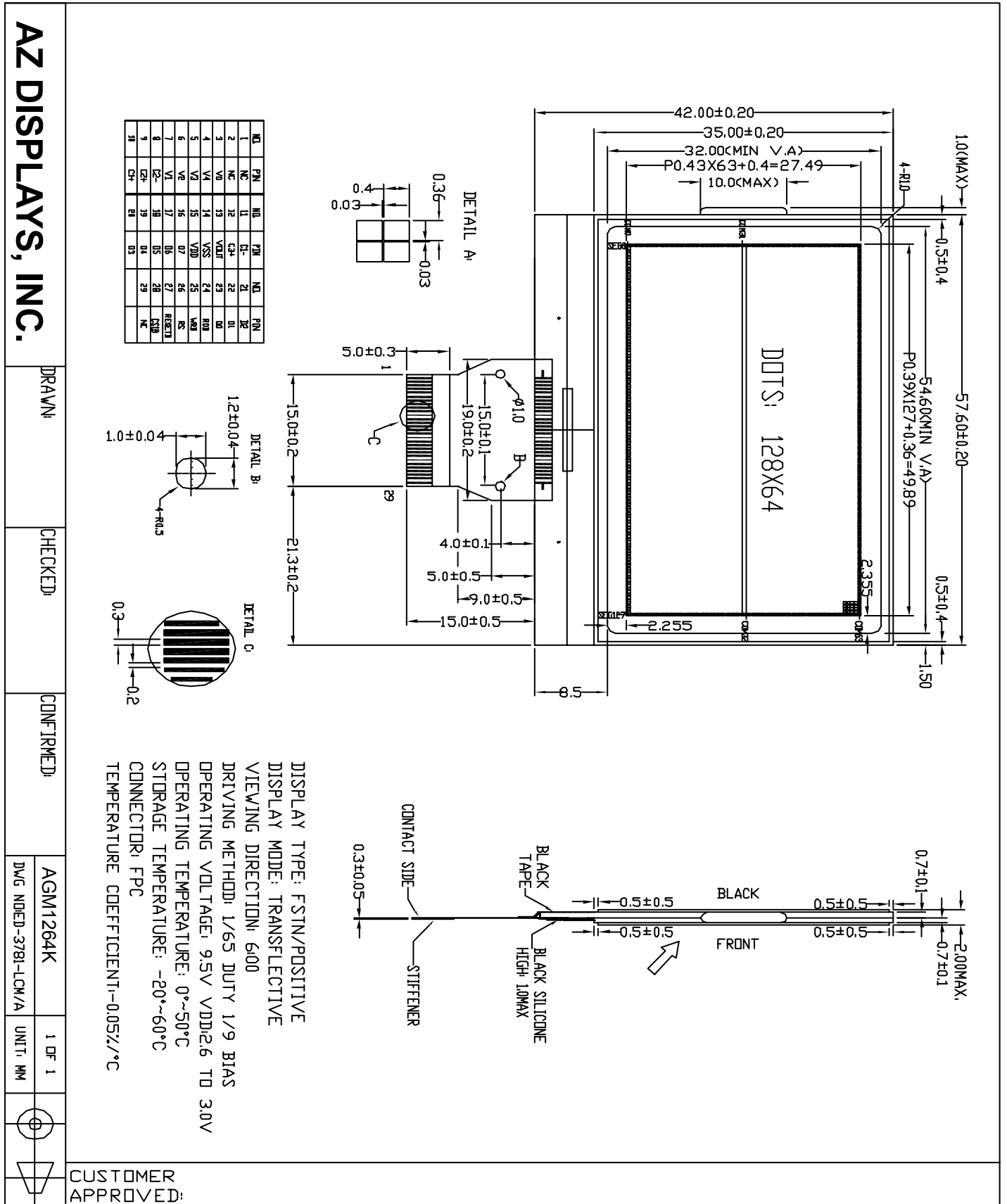

NO.	PN	NO.	PN	NO.	PN
1	NC	11	DE	21	BN
2	NC	12	CA	22	DE
3	VA	13	VDD	23	DE
4	VA	14	VSS	24	RO
5	VE	15	VDD	25	VA
6	VE	16	07	26	RS
7	VA	17	06	27	RES1
8	CA	18	05	28	RES2
9	CA	19	04	29	NC
10	CA	20	03		

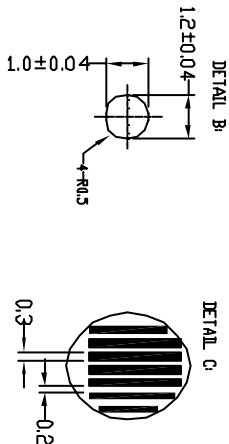

DISPLAY TYPE: FSTN/POSITIVE
 DISPLAY MODE: TRANSPARENT
 VIEWING DIRECTION: 6:00
 DRIVING METHOD: 1/65 DUTY 1/9 BIAS
 OPERATING VOLTAGE: 9.5V VDD:2.6 TO 3.0V
 OPERATING TEMPERATURE: 0°~50°C
 STORAGE TEMPERATURE: -20°~60°C
 CONNECTOR: FPC
 TEMPERATURE COEFFICIENT: -0.05%/°C

4.0 GENERAL SPECIFICATION

1. Overall Module Size	57.6mm(W) x 42.0mm(H) x max 2.0 mm(D)
2. Dot Size	0.36mm(W) x 0.40mm(H)
3. Dot Pitch	0.39mm(W) x 0.43mm(H)
4. Duty	1/65 DUTY ,1/9 BIAS
5. Controller IC	S6B0724
6. LCD Fluid Options	FSTN
7. Polarizer Options	Transflective,
8. Backlight Options	None
9. Temperature Range Options	Operate Tmp (0°C ~ 50°C), Store Tmp (-20°C ~ 60°C)
10. View Angle	6 Clock
11.Active Area	49.89 x 27.49mm
12. View Size	54.6 x 35.0mm

5.0 ABSOLUTE MAXIMUM RATINGS

Item	Symbol	Min	Typ	Max	Unit
Operating temperature (Standard)	Top	0	25	50	°C
Storage temperature (Standard)	Tst	-20	-	60	°C
Input voltage	VI	VSS	-	Vdd	V
Supply voltage for logic	Vdd- Vss	VSS-0.3	-	7.0	V
Supply voltage for LCD drive	Vdd- V _{LCD}	VSS-0.3	9.5	17.0	V

Be sure to be grounded when handling.

6.0 ELECTRICAL CHARACTERISTICS

Ta = 0~45 C, VDD = 2.7~3.6 V, VSS = 0

Item	Symbol	Condition	Min	Typ	Max	Unit	Terminal
Power Supply Voltage	VDD		2.4	3.0	3.6	V	VDD 1*
	VO		9.0	9.5	10.0	V	VO 2*
Power Supply Current	I _{dd}	V _{dd} =3.3V	-	380	650	μA	
Input voltage (high)	V _{ih}	H level	0.8*VDD	-	VDD	V	3*
Input voltage (low)	V _{il}	L level	VSS	-	0.2*VDD	V	
Output Voltage (high)	VOH	I _{OH} = -0.5MA	0.8*VDD	-	VDD	V	4*
Output Voltage (low)	VOL	I _{OL} = -0.5mA	VSS	-	0.2*VDD	V	

1* A spike in voltage may affect other parameters during access from the MPU

2* When external power supply is applied

3* CS1, CS2, RS, DB0 thru DB7, E_RDB, RW_WRB, RESET, MS, C68, PS, INTR, HPMB, CLS, CL, M,FR, DISP pins

4* DB0 thru DB7, M, FR, DISP, CL

7.0 OPTICAL CHARACTERISTICS

ITEM	SYMBOL	CONDITION	MIN.	TYP.	MAX.	UNIT
Viewing Angle	θ (BK-FT)	Cr>2.0 Ta=25 C	-10	/	40	DEG
	Φ (R-L)		-40	/	40	DEG
Contrast Ratio (MAX)	Cr(Max)	θ=0, Φ=0	-	6.0	-	
Response Time (rise)	T _{on}	θ=0, Φ=0 V _{lcd} =9.5 v Ta=25 C	/	/	250	ms
Response Time (fall)	T _{off}		/	/	268	ms

8. AC Characteristics

(1) System buses Read/Write characteristics 1(For the 8080 Series MPU)

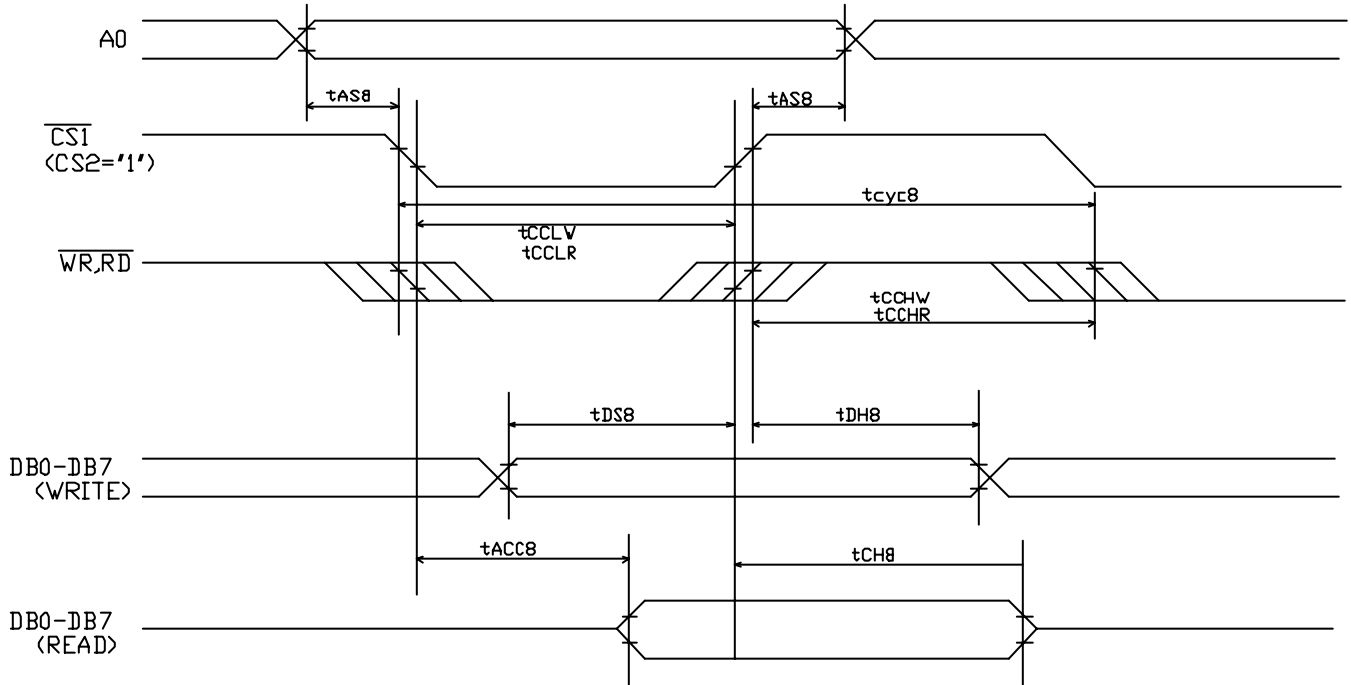

Symbol	Parameter	Min.	Typ.	Max.	Unit	Condition
T _{AH8}	Address hold time	0			ns	A0
T _{AS8}	Address setup time	0			ns	A0
T _{CYC8}	System cycle time	300			ns	
T _{CCLW}	Control L pulse width(WR)	60			ns	/WR
T _{CCLR}	Control L pulse width(RD)	120			ns	/RD
T _{CCHW}	Control H pulse width(WR)	60			ns	/WR
T _{CCHR}	Control H pulse width(RD)	60			ns	/RD
T _{DS8}	Data setup time	40			ns	D0 T0 D7
T _{DH8}	Data hold time	15			ns	D0 T0 D7
T _{ACC8}	RD access time			140	ns	C _L =100pF
T _{CH8}	Output disable time	10		100	ns	C _L =100pF

(2) System buses Read/Write characteristics 2(For the 6800 Series MPU)

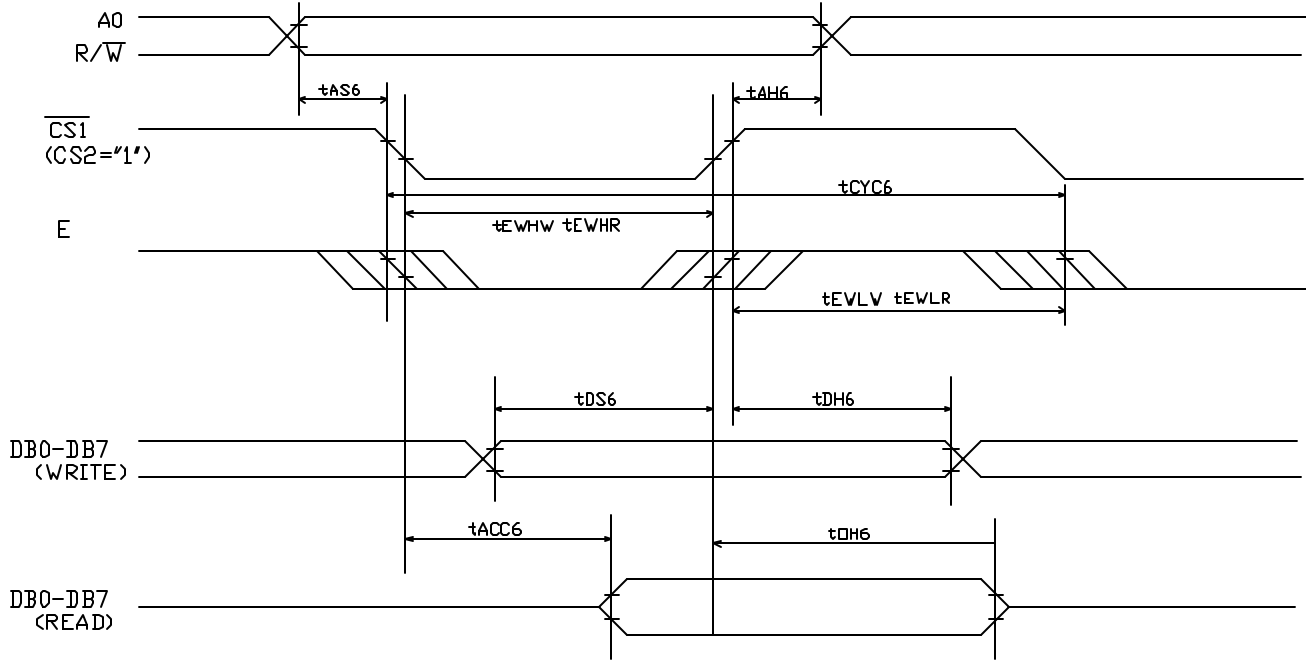

Symbol	Parameter	Min.	Typ.	Max.	Unit	Condition
T_{CYC6}	System cycle time	300			ns	
T_{AS6}	Address setup time	0			ns	A0
T_{AH6}	Address hold time	0			ns	A0
T_{DS6}	Data setup time	40			ns	D0 T0 D7
T_{DH6}	Data hold time	15			ns	D0 T0 D7
T_{OH6}	Output disable time	10		100	ns	$C_L=100pF$
T_{ACC6}	Access time			140	ns	$C_L=100pF$
T_{EWHR}	Enable H pulse width(Read)	120			ns	
T_{EWHW}	Enable H pulse width(Write)	60			ns	
T_{EWLR}	Enable L pulse width(Read)	60			ns	
T_{EWLW}	Enable L pulse width(Write)	60			ns	

(3) Display control timing

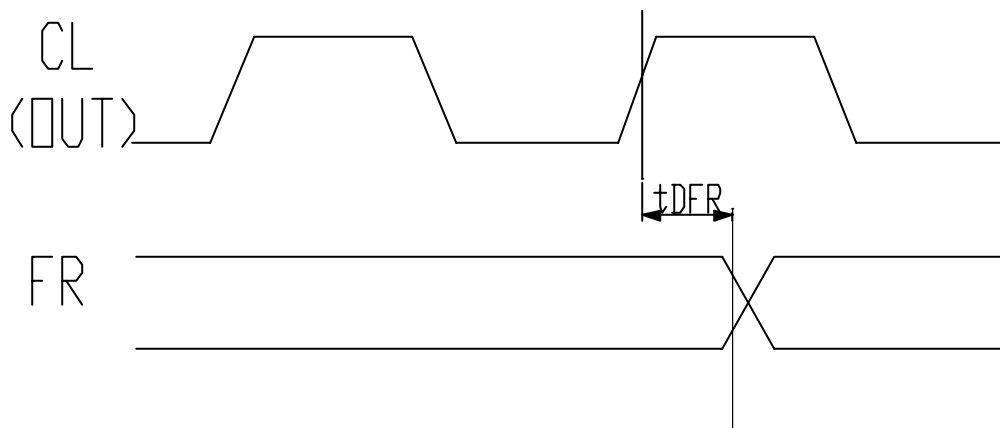

Symbol	Parameter	Min.	Typ.	Max.	Unit	Condition
TDFR	FR delay time		20	80	ns	CL=50pF

(4) Reset timing

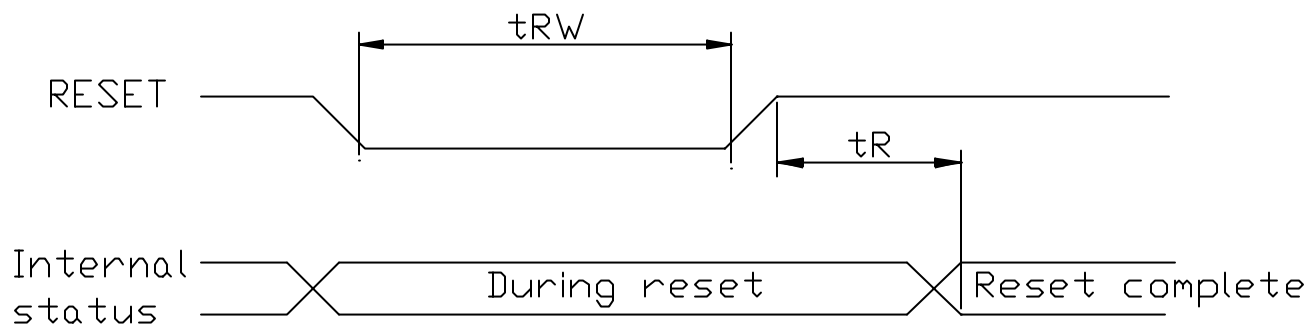

Symbol	Parameter	Min.	Typ.	Max.	Unit	Condition
TR	Reset time			1.0	μs	
TW	Reset low pulse width	1.0			μs	

(5) Instruction Table

Command	Code											Function
	A0	RD	WR	D7	D6	D5	D4	D3	D2	D1	D0	
1.Display ON/OFF	0	1	0	1	0	1	0	1	1	1	D	Turns on LCD panel when goes high, and turns off when goes low
2.Set Display Start Line	0	1	0	0	1	Display start address					Specifies RAM display line for COM0	
3.Set Page Address	0	1	0	1	0	1	1	Page address				Sets the display RAM page in Page Address register
4.Set Column Address 4 higher bits	0	1	0	0	0	0	1	Higher column address				Sets 4 higher bits of column address of display RAM in register
4.Set Column Address 4 lower bits	0	1	0	0	0	0	0	Lower column address				Sets 4 higher bits of column address of display RAM in register
5.Read Status	0	0	1	Status				0	0	0	0	Reads the status information
6.Write Display Data	1	1	0	Write data								Writes data in display RAM
7.Read Display Data	1	0	1	Read data								Reads data from display RAM
8.ADC select	0	1	0	1	0	1	0	0	0	0	D	Sets the display RAM address SEG output correspondence
9.Normal/Reverse Display	0	1	0	1	0	1	0	0	1	1	D	Normal indication when low, but full indication when high
10.Entire Display ON/OFF	0	1	0	1	0	1	0	0	1	0	0 1	Selects normal display (0) or Entire Display ON (1)
11.Set LCD Bias	0	1	0	1	0	1	0	0	0	1	D	Sets LCD drive voltage bias ratio
12.Read-Modify-Write	0	1	0	1	1	1	0	0	0	0	0	Increments Column Address counter during each write
13.END	0	1	0	1	1	1	0	1	1	1	0	Releases the Read-Modify-Write
14.Reset	0	1	0	1	1	1	0	0	0	1	0	Resets internal functions
15.Common output mode select	0	1	0	1	1	0	0	D	*	*	*	Selects COM output scan direction.* Invalid data
16.Set Power Control	0	1	0	0	0	1	0	1	Operation status			Selects the power circuit operation mode
17.V0 voltage regulator internal resistor ratio set	0	1	0	0	0	1	0	0	Resistor ratio			Select internal resistor ratio (Rb/Ra) mode
18.Electronic volume mode set	0	1	0	1	0	0	0	0	0	0	1	Set the V0 output voltage electronic volume register
Electronic volume Register set	0	1	0	*	*	Electronic control value						

19.Set static indicator ON/OFF Set Static indicator register	0	1	0	1	0	1	0	1	1	0	D	Set static indicator On/Off 0:OFF 1:ON
	0	1	0	*	*	*	*	*	*	*	Mode	Set the flashing mode
20.Power Save	-	-	-	-	-	-	-	-	-	-	-	Compound command of display OFF and entire display ON
21.NOP	0	1	0	1	1	1	0	0	0	1	1	Command for non-operation
22.Test Command	0	1	0	1	1	1	1	*	*	*	*	IC Test command. Do not use!
23.Test Mode Reset	0	1	0	1	1	1	1	0	0	0	0	Command of test mode reset

9. OPTICAL MEASUREMENT SYSTEM

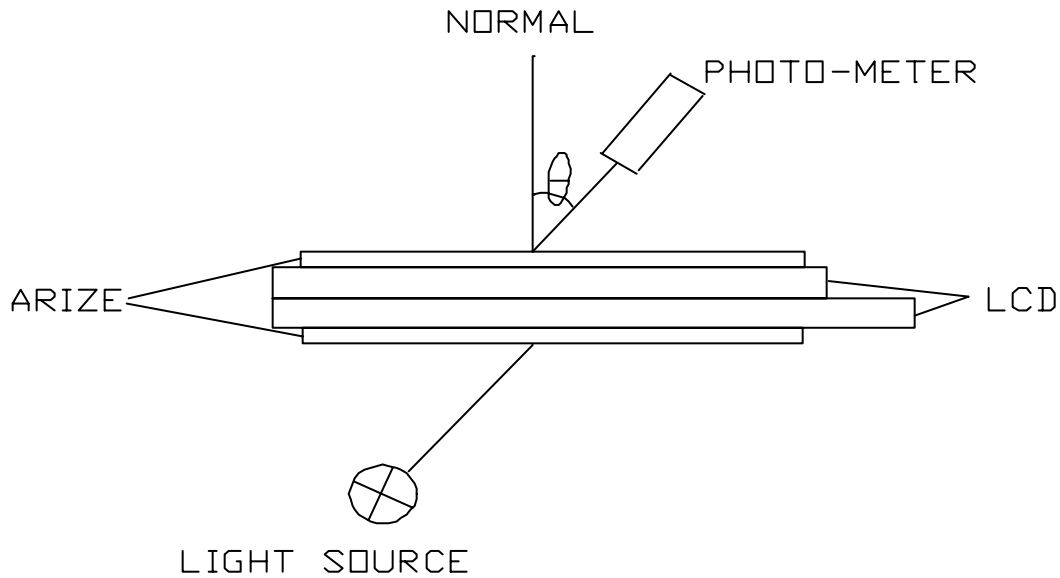

9.1 DEFINITION OF θ AND ϕ

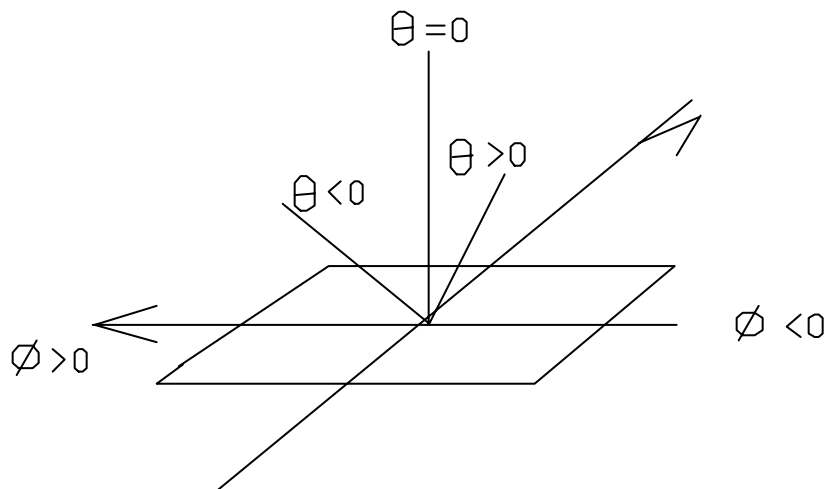

9.3 DEFINITION OF CONTRAST RATIO Cr

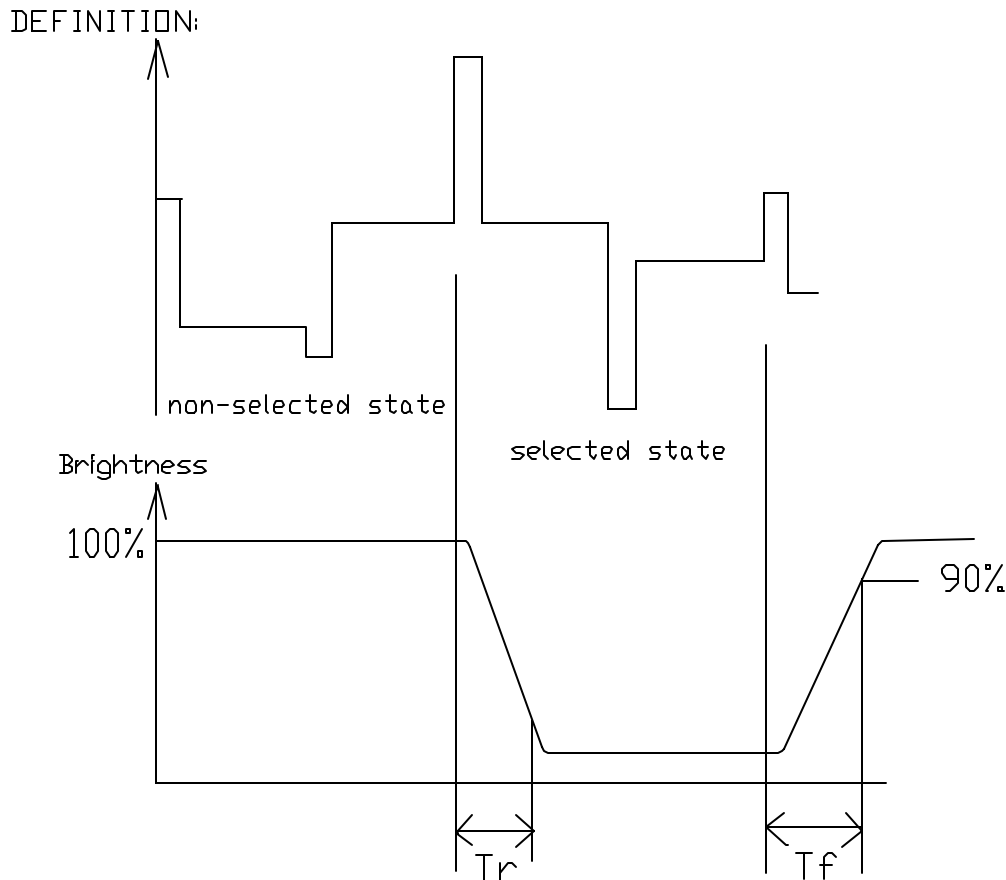

7.4 DEFINITION OF OPTICAL RESPONSE TIME

8.0 INTERFACE

PIN NO.	SYMBOL	PIN NO.	SYMBOL
1	NC	16	D7
2	P/S	17	D6
3	V0	18	D5
4	V4	19	D4
5	V3	20	D3
6	V2	21	D2
7	V1	22	D1
8	CAP2-	23	D0
9	CAP2+	24	/RD
10	CAP1+	25	/WR
11	CAP1-	26	A0
12	CAP3+	27	/RES
13	VOUT	28	/CS
14	VSS	29	NC
15	VDD		

10.0 Content of Reliability Test

Environmental Test			
No.	Test Item	Content of Test	Condition
1	High Temperature Storage	Endurance test applying the high temperature for a long time,power off.	60? 96H
2	Low Temperature Storage	Endurance test applying the low temperature for a long time,power off.	-20? 96H
3	High Temperature Operation	Endurance test applying the high temperature for a long time,power on.	50? 24H
4	Low Temperature Operation	Endurance test applying the low temperature for a long time,power on	0? 24H

Driving condition for operating test.

Power supply voltage for logic (VDD) = 3.0V

10.1 Failure Judgment Criterion

After the above-mentioned test

There should not exist conspicuous failure of display quality and appearance.

No degradation of the display readability.

There should not have any abnormality of function.

11.0 Handling Precautions

- As LCD module is glass product of precision processing and special treatment, it is vulnerable enough to have chips and cracks easily. And especially edges should be protected from shocks. If the liquid crystal in LCD flows out when the product is broken, pay most attention to that you do not put the liquid crystal into your eyes and mouth. If the liquid crystal touches your hand, skin, or clothing, wash it away with soap and water immediately and completely.
- The polarizer on LCD is soft and easily scratched. If the surface is stained, use soft dry cloth and wipe gently. If the surface is heavily stained, use the following solvents: 1, Isopropyl alcohol. 2, ethyl alcohol. Other solvents may damage the polarizer. Especially, do not use water, ketone and aromatic solvents.
- Do not give any pressure to the surface of LCD, and do not give excessive stresses to the side of LCD module. It may cause a distortion of color on the LCD.
- As LCD module uses CMOS devices, it is very sensitive to static electricity.
- Touching the IC of LCD module may cause abnormal display that cannot recover. Should not touch the IC of LCD module.
- If the logic circuit power is OFF, do not apply the input signals.
- Be sure to ground the body when handling the LCD module.
- Tools required for assembly, such as soldering irons, must be properly grounded.
- To prevent destruction of the elements by static electricity be careful to maintain an optimum work environment.
- Do not forcibly pull or bend the I/O cable.
- Do not disassemble or process the LCD module.
- NC terminal should be open. Do not connect anything.
- To reduce the amount of static electricity generated, do not conduct assembly and other work under dry conditions.
- The LCD module is coated with a film to protect the display surface. Take care when peeling

off this protective film since static electricity may be charged.
Please handle carefully, because the glass has a sharp edge.

12.1 Storage Precautions

Take care to minimize corrosion of the electrode. Moisture condensation on a current flow in a high humidity environment accelerates corrosion of the electrode.

When storing the LCD module, avoid exposure to direct sunlight or to the light of fluorescent lamps. Keep the LCD module in bags designed to prevent static electricity charging under low temperature/normal humidity conditions (avoid high temperature/ high humidity and low temperature below 0?).

12.2 Design Precautions

The absolute maximum ratings represent the rated value beyond which LCD module can not exceed. When the LCD module is used in excess of this fated value, their operating characteristics may be adversely affected. To prevent the occurrence of erroneous operation caused by the noise, attention must be paid to satisfy VIL, VIH specification values, including taking the precaution of using signal cables that are short.

The liquid crystal display exhibits temperature dependency characteristics. Since recognition of the display becomes difficult when the LCD is used out of its designated operating temperature range, be sure to use the LCD within this range.

We recommend that power supply lines (VDD, VEE) have over-current protection line. (Fuse etc.)

Sufficiently notice the mutual noise interference occurred by peripheral devices.

To cope with EMI, take measure basically on outputting side.

When fixing LCD module, which is consisted of glass panel, TCP fixes it at plastic case side. In case PCB is fixed, there is the possibility that the disconnection is occurred by somewhat stress.

When mounting the LCD module, make sure that it is free of twisting, warping and distortion. Distortion has great influence upon display quality. Also keep the shiftiness enough regarding the outer case.

12.3 Other

Liquid crystal solidify under low temperatures (below the storage temperature range) leading to defective orientation or the generation of air bubbles. Air bubbles may also be generated if the LCD module is subjected to a strong shock at a low temperature.

If the LCD module has been operating for a long time showing the same display patterns, the display patterns may remain on the screen as ghost images and a slight contract irregularity may also appear. A normal operating status can be regained by suspending use for some time it should be noted that this phenomenon does not adversely affect performance reliability.

To minimize the performance degradation of the LCD modules resulting from destruction caused sections by static electricity, etc, take care to avoid touching the following sections when handing the module.

? Terminal electrode sections, ? Part of pattern wiring on TCP, etc.