



晶采光電科技股份有限公司  
AMPIRE CO., LTD.

## SPECIFICATIONS FOR LCD MODULE

<b>CUSTOMER</b>	
<b>CUSTOMER PART NO.</b>	
<b>AMPIRE PART NO.</b>	<b>AG-320240A4FIQW-K9H-S(N)(R)</b>
<b>APPROVED BY</b>	
<b>DATE</b>	

**Approved For Specifications**

Approved For Specifications & Sample

AMPIRE CO., LTD.

2F., No.88, Sec. 1, Sintai 5th Rd., Sijih City, Taipei County 221, Taiwan (R.O.C.)

台北縣汐止市新台五路一段 88 號 2 樓(東方科學園區 D 棟)

TEL:886-2-26967269 , FAX:886-2-26967196 or 26967270

APPROVED BY	CHECKED BY	ORGANIZED BY

## RECORD OF REVISION

Revision Date	Page	Contents	Editor
2009/05/06	-	New Release	Emil

## 1 FEATURES

- (1) Display format: 320 × 240 dot-matrix, 1/240 duty.
- (2) Construction: FSTN LCD, Bezel, Heat Seal, Zebra, White LED back-light and PCB.
- (3) Display type : FSTN, Transflective, 6 o'clock view
- (4) Controller: RA8835AP4N.
- (5) Common and Segment Driver: SDN8080G.
- (6) With temperature compensation circuit.
- (7) Power: +5V for logic circuit, Built-in DC/DC converter for LCD driving.
- (8) Extended temperature type.

## 2 MECHANICAL DATA

Parameter	Stand Value	Unit
Dot size	0.345(W) × 0.345(H)	mm
Dot pitch	0.36(W) × 0.36(H)	mm
Viewing area	122.0(W) × 92.0(H)	mm
Module size	167.0(W) × 109.0(H) × 14.5 max (T)	mm

## 3 ABSOLUTE MAXIMUM RATINGS

Parameter		Symbol	Min	Max	Unit
Logic Circuit Supply Voltage		VDD-VSS	-0.3	7.0	V
LCD Driving Voltage		VDD-VO	-0.3	26.0	V
Input Voltage		VI	-0.3	VDD+0.3	V
Extended temp. type	Operating Temp.	TOP	-20	70	°C
	Storage Temp.	TSTG	-30	80	°C

## 4 ELECTRO-OPTICAL CHARACTERISTICS

Parameter	Symbol	Condition	Min	Typ	Max	Unit	Note
<b>----- Electronic Characteristics -----</b>							
Logic Circuit Supply Voltage	VDD-VSS	--	--	5.0	--	V	
LCD Driving Voltage	VDD-VO	25 °C	23.0	24.2	25.4	V	
Input Voltage	VIH	--	0.7 VDD	--	VDD	V	
	VIL	--	VSS	--	0.3 VDD	V	
Logic Supply Current	IDD	VDD = 5V	--	50	--	mA	
<b>----- Optical Characteristics -----</b>							
Contrast	CR	FSTN type	--	7	--		Note 1
Rise Time	tr	25°C	--	200	300	ms	Note 2
Fall Time	tf	25°C	--	200	300	ms	
Viewing Angle Range	θ f	25°C & CR≥2	--	35	--	Deg.	Note 3
	θ b		--	30	--		
	θ l		--	30	--		
	θ r		--	30	--		
Frame Frequency	FF	25°C	--	64	--	Hz	

(NOTE 1) Contrast ratio :

CR = (Brightness in OFF state) / (Brightness in ON state)

( NOTE 2 ) Response time :

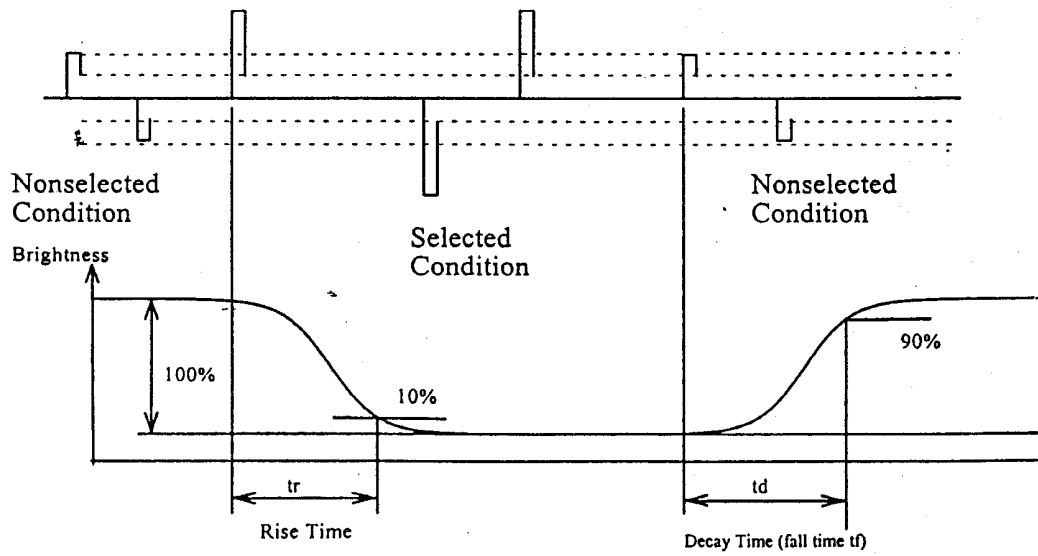

(NOTE 3) Viewing angle

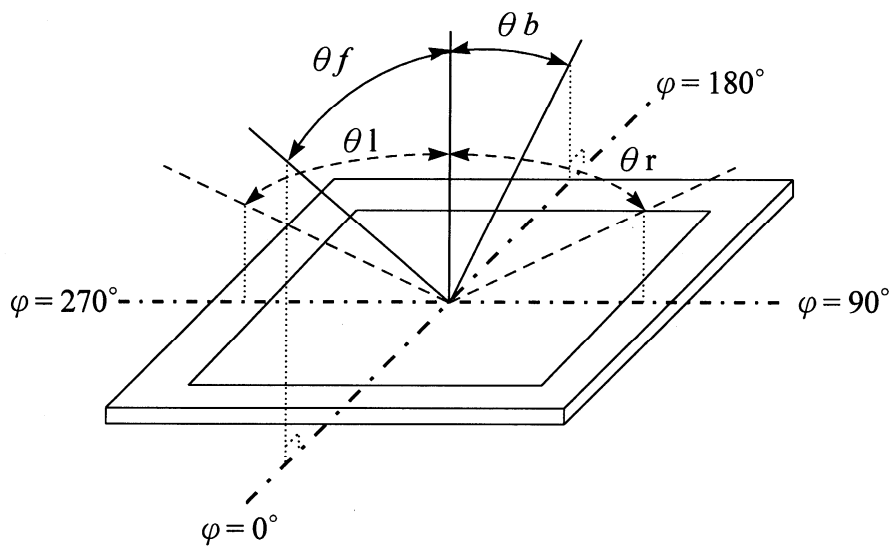

## 4.1 LED Back-light Electrical Specification

----- White LED Back-light Characteristics -----							
Parameter	Symbol	Condition	Min	Typ	Max	Unit	Note
Forward Current	IF	--	--	90	120	mA	Note 4
LCM Luminous intensity		IF=90mA	--	38	--	cd/m <sup>2</sup>	Note 4
Forward Voltage	VF	IF=90mA	--	3.2	3.5	V	Note 5
LED C.I.E	X	IF=90mA	0.28	0.31	0.34		Note 6
	Y	IF=90mA	0.29	0.32	0.35		

Note 4: Luminous intensity is decided by forward current of White LED.

Note 5: White LEDs are with voltage tolerance under the same current.

Note 6: White LEDs are with color tolerance under the same current.

\* LED Dice number = 6

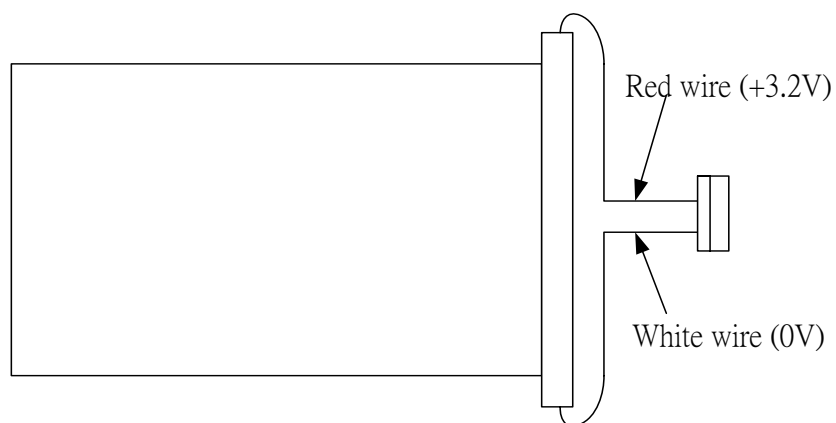
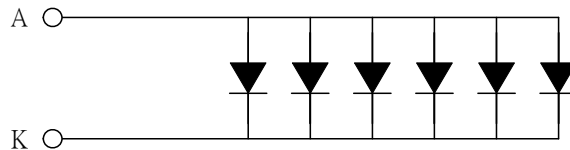

## 5 BLOCK DIAGRAM & POWER SUPPLY

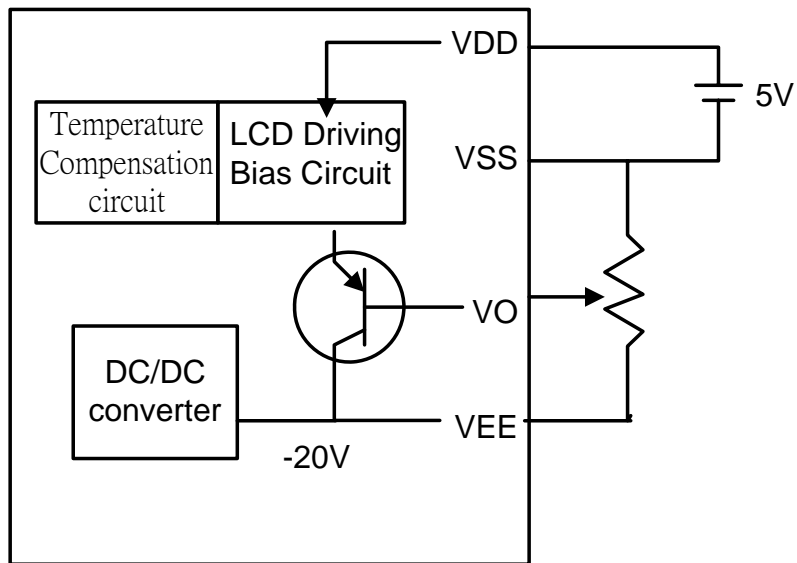
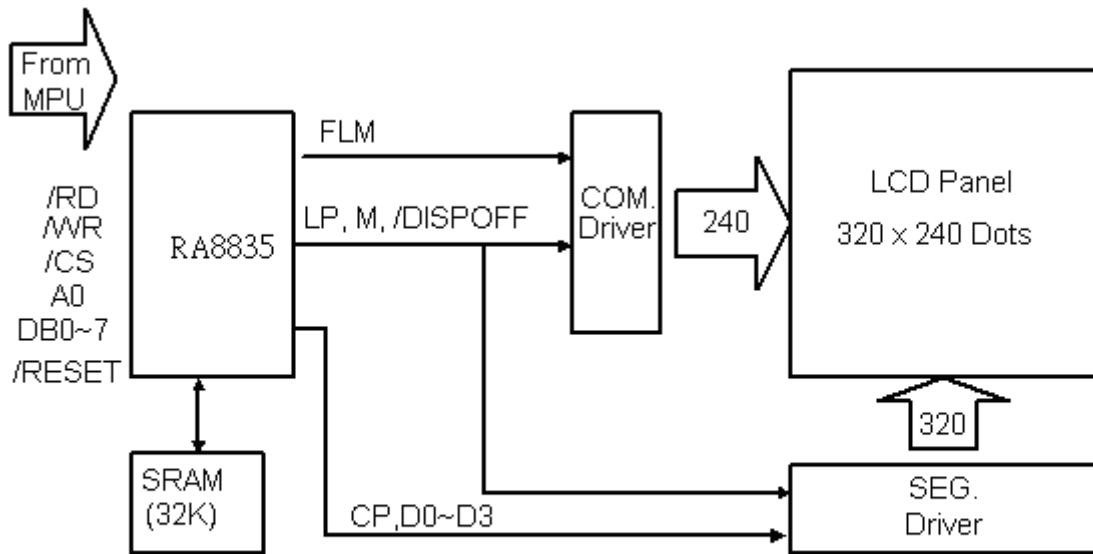

With DC/DC converter

## 6 PIN CONNECTIONS

PIN NO.	SIGNAL	LEVEL	FUNCTION
1	/RESET	H/L	Reset Signal
2	/RD	H/L	80 Series: Read Signal 68 Series: Enable Signal(E)
3	/WR	H/L	80 Series: Write Signal 68 Series: R/W Signal
4	/CS	H/L	Chip Select Signal
5	A0	H/L	Data Type Selection
6 ~ 13	DB0~DB7	H/L	Data Input(8 bits)
14	VDD	-	Power Supply for Logic(+5.0V)
15	VSS	-	Power Supply(Ground : 0V)
16	VEE	-	DC/DC Negative voltage output (-20V)
17	VO	-	Contrast Adjustment Input
18-24	NC	--	No Connection



## 7 TIMING CHARACTERISTICS

### 7.1 8080 Family Interface Timing

Parameter	Condition	Symbol	Min	Max	Unit	Remark
Address Hold Time	CL=100 pF VDD=2.7~4.5	$t_{AH8}$	10		ns	A0,/CS
Address Setup Time		$t_{AW8}$	0		ns	
System Cycle Time		$t_{CYC}$	Note		ns	/WR,/RD
Strobe Pulse Width		$t_{OC}$	150		ns	
Data Setup Time		$t_{DS8}$	120		ns	DB0~DB7
Data Hold Time		$t_{DH8}$	5		ns	
/RD Access Time		$t_{ACC8}$	-	80	ns	
Output Disable Time		$t_{OH8}$	10	55	ns	

Note: For memory control and system control commands:

$$t_{CYC8} = 2t_C + t_{OC} + t_{CEA} + 75 > t_{ACV} + 245$$

For all other commands:

$$t_{CYC8} = 4t_C + t_{OC} + 30$$

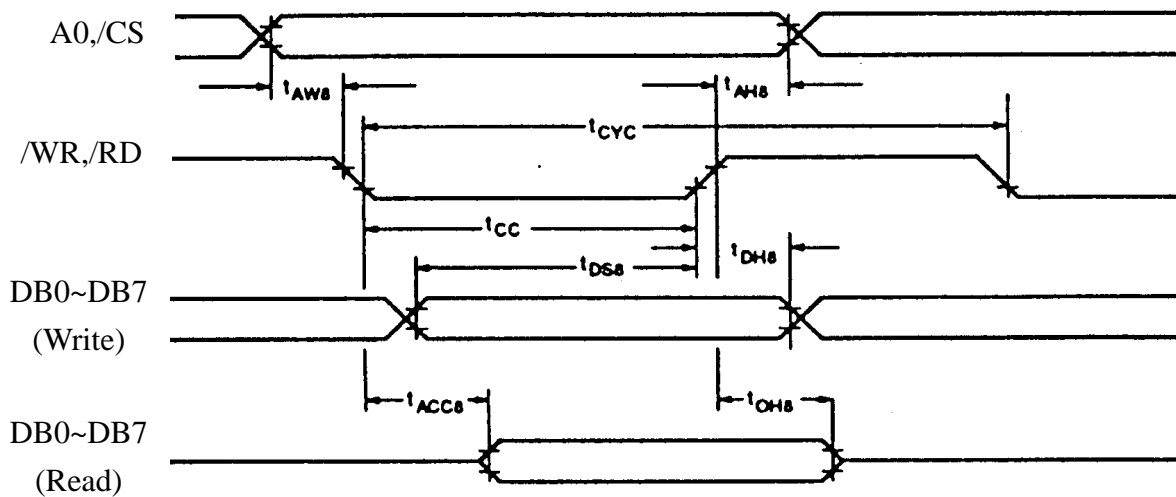

## 7.2 6800 Family Interface Timing

Parameter	Condition	Symbol	Min	Max	Unit	Remark
System Cycle Time	CL=100 pF VDD=2.7~4.5	$t_{CYC6}$	Note		ns	A0,/CS, R/W
Address Setup Time		$t_{AW6}$	10		ns	
Address Hold Time		$t_{AH6}$	0		ns	
Data Setup Time		$t_{DS6}$	120		ns	DB0~DB7
Data Hold Time		$t_{DH6}$	0		ns	
Output Disable Time		$t_{OH6}$	10	75	ns	
Access Time		$t_{ACC6}$	-	130	ns	
Enable Pulsewidth			$t_{EW}$	150	-	ns

Note: For memory control and system control commands:

$$t_{CYC6} = 2t_C + t_{EW} + t_{CEA} + 75 > t_{ACV} + 245$$

For all other commands:

$$t_{CYC6} = 4t_C + t_{EW} + 30$$

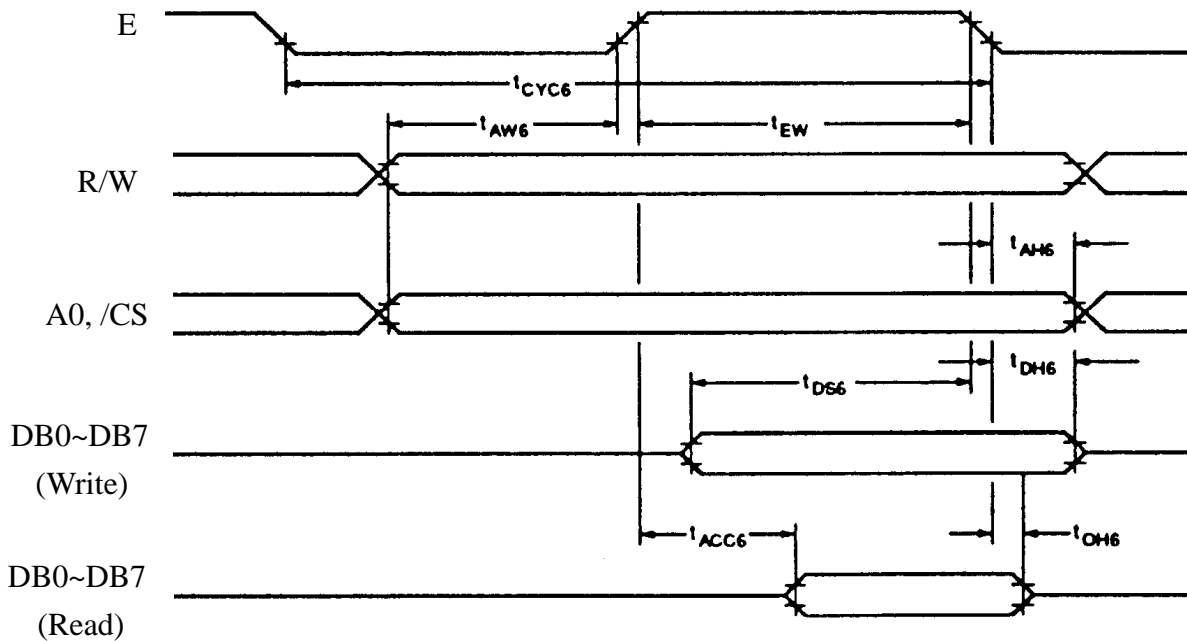

AC Electrical Characteristics

## 8 INSTRUCTION SET

Class	Command	Code											Hex	Command Description	Command read parameters	
		/RD	/WR	A0	D7	D6	D5	D4	D3	D2	D1	D0			Number of bytes	Section
System Control	SYSTEM SET	1	0	1	0	1	0	0	0	0	0	0	40	Initialized Device and display	8	8.2.1
	SLEEP IN	1	0	1	0	1	0	1	0	0	1	1	53	Enter Standby mode	0	8.2.2
Display Control	DISP ON/OFF	1	0	1	0	1	0	1	1	0	0	D	58, 59	Enable and disable display and display flashing	1	8.3.1
	SCROLL	1	0	1	0	1	0	0	0	1	0	0	44	set Display start address and display regions	10	8.3.2
	CSRFORM	1	0	1	0	1	0	1	1	1	0	1	5D	Set cursor byte	2	8.3.3
	CGRAM ADDR.	1	0	1	0	1	0	1	1	1	0	0	5C	Set start address of character generator RAM	2	8.3.6
	CSRDIR	1	0	1	0	1	0	0	1	1	CD 1	CD 0	4C to 4F	Set direction of cursor movement	0	8.3.4
	HDOT SCR	1	0	1	0	1	0	1	1		1	0	5A	set horizontal scroll position	1	8.3.7
	OVLAY	1	0	1	0	1	0	1	1	0	1	1	5B	set display overlay format	1	8.3.5
Drawing Control	CSRW	1	0	1	0	1	0	0	0	1	1	0	46	set cursor address	2	8.4.1
	CSRR	1	0	1	0	1	0	0	0	1	1	1	47	read cursor address	2	8.4.2
Memory Control	MWRITE	1	0	1	0	1	0	0	0	0	1	0	42	write to display memory	-	8.5.1
	MREAD	1	0	1	0	1	0	0	0	0	1	1	43	read from display memory	-	8.5.2

Note:

- In general, the internal registers of the SED1335F are modified as each command parameter is input. However, the microprocessor does not have to set all the parameters of a command and may send a new command before all parameters have been input. The internal registers for the parameters that have been input will have been changed but the remaining parameter registers are unchanged.
  - 2 bytes parameters( where two bytes are treated as 1 data item) are handled as following:
    - CSRW, CSRR: Each byte is processed individually. The microprocessor may read or write just the low byte of the cursor address.
    - SYSTEM SET, SCROLL, CGRAM ADR. : Both parameter bytes are processed together. If the command is changed after half of the parameter has been input, the single byte is ignored.
- APL and APH are 2-byte parameters, but are treated as two 1-byte parameters.
- Please refer to SED1335F LCD Controller Data Book for detail.

## 8.1 Power ON/OFF Sequence

Please maintain the blow sequence when turning on and off the power supply of the module. If /DISPOFF is supplied to the module while internal alter signal for LCD driving (M) is unstable, DC component will be supplied to the LCD panel. This may cause damage the LCD module.

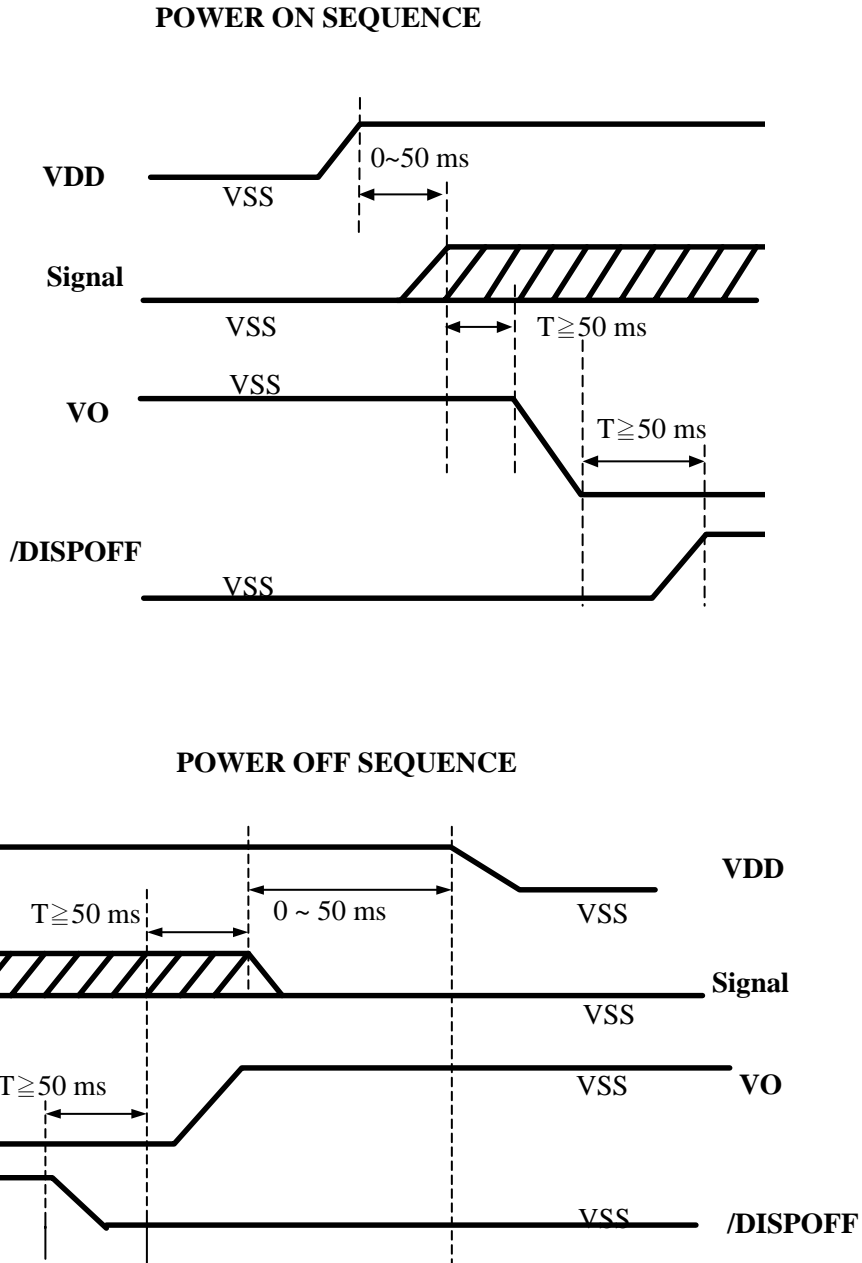

## 9 JUMPER SETTING

Item	Option	Jumper Setting	Remark
MPU	80 family (default)	Pin 1,2 short on JP6	
	68 family	Pin 2,3 short on JP6	

## 10 QUALITY AND RELIABILITY

### 10.1 TEST CONDITIONS

Tests should be conducted under the following conditions :

Ambient temperature :  $25 \pm 5^{\circ}\text{C}$

Humidity :  $60 \pm 25\% \text{ RH}$ .

### 10.2 SAMPLING PLAN

Sampling method shall be in accordance with MIL-STD-105E , level II, normal single sampling plan .

### 10.3 ACCEPTABLE QUALITY LEVEL

A major defect is defined as one that could cause failure to or materially reduce the usability of the unit for its intended purpose. A minor defect is one that does not materially reduce the usability of the unit for its intended purpose or is an infringement from established standards and has no significant bearing on its effective use or operation.

### 10.4 APPEARANCE

An appearance test should be conducted by human sight at approximately 30 cm distance from the LCD module under fluorescent light. The inspection area of LCD panel shall be within the range of following limits.

## 10.5 INSPECTION QUALITY CRITERIA

Item	Description of defects			Class of Defects	Acceptable level (%)
Function	Short circuit or Pattern cut			Major	0.65
Dimension	Deviation from drawings			Major	1.5
Black spots	Ave . dia . D	area A	area B	Minor	2.5
	$D \leq 0.2$	Disregard			
	$0.2 < D \leq 0.3$	3	4		
	$0.3 < D \leq 0.4$	2	3		
	$0.4 < D$	0	1		
Black lines	Width W, Length L	A	B	Minor	2.5
	$W \leq 0.03$	disregard			
	$0.03 < W \leq 0.05$	3	4		
	$0.05 < W \leq 0.07, L \leq 3.0$	1	1		
	See line criteria				
Bubbles in polarizer	Average diameter D $0.2 < D < 0.5$ mm for N = 4 , D > 0.5 for N = 1			Minor	2.5
Color uniformity	Rainbow color or nektion ring.			Minor	2.5
Glass Scratches	Obvious visible damage.			Minor	2.5
Contrast ratio	See note 1			Minor	2.5
Response time	See note 2			Minor	2.5
Viewing angle	See note 3			Minor	2.5

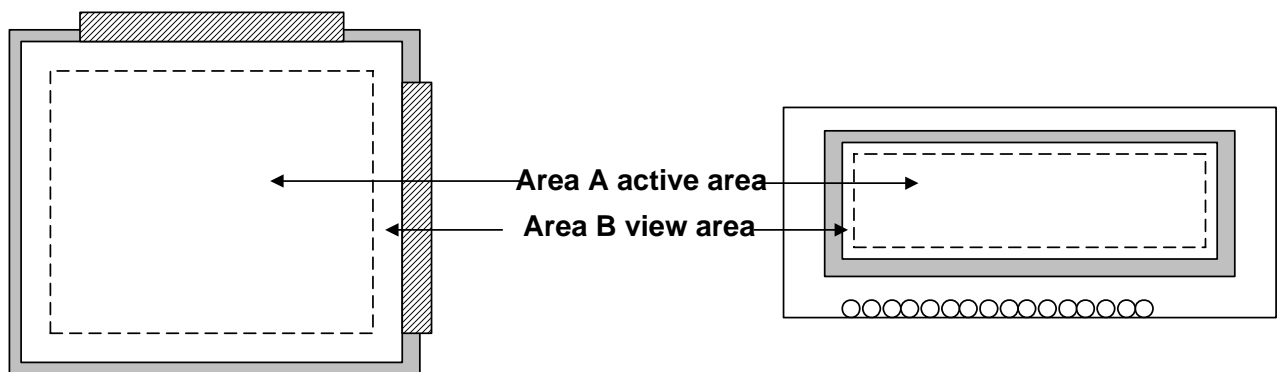

## 10.6 RELIABILITY

Test Item	Test Conditions		Note
	Normal Temp. type	Extended Temp. type	
High Temperature Operation	50±3°C , t=96 hrs	70±3°C , t=96 hrs	
Low Temperature Operation	0±3°C , t=96 hrs	-20±3°C , t=96 hrs	
High Temperature Storage	70±3°C , t=96 hrs	80±3°C , t=96 hrs	1,2
Low Temperature Storage	-20±3°C , t=96 hrs	-30±3°C , t=96 hrs	1,2
Temperature Cycle	-20°C ~ 25°C ~ 70°C 30 min. 5 min. 30 min. ( 1 cycle ) Total 5 cycle	-30°C ~ 25°C ~ 80°C 30 min. 5 min. 30 min. ( 1 cycle ) Total 5 cycle	1,2
Humidity Test	40 °C, Humidity 90%, 96 hrs		1,2
Vibration Test (Packing)	Sweep frequency : 10 ~ 55 ~ 10 Hz/1min Amplitude : 0.75mm Test direction : X.Y.Z/3 axis Duration : 30min/each axis		2

Note 1 : Condensation of water is not permitted on the module.

Note 2 : The module should be inspected after 1 hour storage in normal conditions  
(15-35°C , 45-65%RH).

Definitions of life end point :

- Current drain should be smaller than the specific value.
- Function of the module should be maintained.
- Appearance and display quality should not have degraded noticeably.
- Contrast ratio should be greater than 50% of the initial value.

## **11 HANDLING PRECAUTIONS**

- (1) A LCD module is a fragile item and should not be subjected to strong mechanical shocks.
- (2) Avoid applying pressure to the module surface. This will distort the glass and cause a change in color.
- (3) Under no circumstances should the position of the bezel tabs or their shape be modified.
- (4) Do not modify the display PCB in either shape or positioning of components.
- (5) Do not modify or move location of the zebra or heat seal connectors.
- (6) The device should only be soldered to during interfacing. Modification to other areas of the board should not be carried out.
- (7) In the event of LCD breakage and resultant leakage of fluid do not inhale, ingest or make contact with the skin. If contact is made rinse immediately.
- (8) When cleaning the module use a soft damp cloth with a mild solvent, such as Isopropyl or Ethyl alcohol. The use of water, ketone or aromatic is not permitted.
- (9) Prior to initial power up input signals should not be applied.
- (10) Protect the module against static electricity and observe appropriate anti-static precautions.



# 12 OUTLINE DIMENSION

