

Preliminary

The contents of this document are confidential and must not be disclosed wholly or in part to any third part without the prior written consent of AMPIRE CO., LTD



晶采光電科技股份有限公司
AMPIRE CO., LTD.

SPECIFICATIONS FOR LCD MODULE

CUSTOMER	
CUSTOMER PART NO.	
AMPIRE PART NO.	AM-1024600KTMQW-00H
APPROVED BY	
DATE	

Approved For Specifications

Approved For Specifications & Sample

AMPIRE CO., LTD.

**4F., No.116, Sec. 1, Xintai 5th Rd., Xizhi Dist., New Taipei City 221,
Taiwan (R.O.C.)**

22181 新北市 汐止區 新台五路一段 116 號 4 樓(東方科學園區 A 棟)

TEL:886-2-26967269 , FAX:886-2-26967196 or 26967270

APPROVED BY	CHECKED BY	ORGANIZED BY

Preliminary

The contents of this document are confidential and must not be disclosed wholly or in part to any third part without the prior written consent of AMPIRE CO., LTD

RECORD OF REVISION

Revision Date	Page	Contents	Editor
2012/4/17	--	New Release	Rober
2012/5/25	--	Added the VLED=5V	Rober

Preliminary

The contents of this document are confidential and must not be disclosed wholly or in part to any third part without the prior written consent of AMPIRE CO., LTD

1. Features

7 inch Amorphous-TFT-LCD (Thin Film Transistor Liquid Crystal Display) module. This module is composed of a 7" TFT-LCD panel, LED backlight, LED driver unit and power circuit unit.

- (1) Construction: 7" a-Si TFT active matrix, White LED Backlight and power & LED driver.
- (2) Resolution (pixel): 1024(R.G.B) X600
- (3) Number of the Colors : 16M colors (R , G , B 6 bit digital each)
- (4) LCD type : Transmissive , normally White
- (5) Interface: LVDS interface 6bit (default), 8bit by jumper setting.
- (6) Power Supply Voltage: 3.3V for logic voltage, 5V or 12V for LED driver power voltage.
- (7) Viewing Direction: 6 O'clock (The direction it's hard to be discolored)

2. PHYSICAL SPECIFICATIONS

Item	Specifications	unit
LCD size	7 inch (Diagonal)	
Resolution	1024 x 3(RGB) x 600	dot
Dot pitch	0.05(W) x 0.15(H)	mm
Active area	153.6(W) x 90.0(H)	mm
Module size	165. 5(W) x 104.44(H) x 7.41(D)	mm
Surface treatment	Hard Coating, Glare	
Color arrangement	RGB-stripe	
interface	LVDS	
Brightness	500	cd/m ²
Weight	TBD	g

Preliminary

The contents of this document are confidential and must not be disclosed wholly or in part to any third part without the prior written consent of AMPIRE CO., LTD

3. ABSOLUTE MAX. RATINGS

Item	Symbol	Values		UNIT	Note
		Min.	Max.		
Power voltage	VCC	-0.3	4.2	V	
	VLED	-0.3	14		
Operation temperature	TOP	-20	70	°C	
Storage temperature	TST	-30	80	°C	

The following values are maximum operation conditions , If exceeded , it may cause faulty operation or damage

Preliminary

The contents of this document are confidential and must not be disclosed wholly or in part to any third part without the prior written consent of AMPIRE CO., LTD

4. ELECTRICAL CHARACTERISTICS**4-1 Typical Operation Conditions**

Item	Symbol	Values			Unit	Remark	
		MIN	TYP	MAX			
Power Voltage	V_{CC}	3.0	3.3	3.6	V	Note 1,2	
Power Consumption	I_{CC}	--	150	--	mA	Note 1,2 $V_{CC}=3.3V$	
Logic Input Voltage	Input Voltage	V_{IN}	0	-	V_{CC}	V	
	Logic input high voltage	V_{TH}	$0.7V_{CC}$	-	V_{CC}	V	Note 3
	Logic input low voltage	V_{TL}	GND	-	$0.3V_{CC}$	V	Note 3

Note 1: Value for Power Board combined panel.

Note 2: VCC setting should match the signals output voltage (refer to Note 3) of customer's system board.

Note 3: LVDS.

Preliminary

The contents of this document are confidential and must not be disclosed wholly or in part to any third part without the prior written consent of AMPIRE CO., LTD

4-2 LED Driving Conditions

Item	Symbol	Values			Unit	Note
		Min.	Typ.	Max.		
LED Driver Power Voltage	V_{LED}	5	--	12	V	
LED Driver Current Consumption	I_{LED}	--	800	--	mA	$V_{LED}=5V$ $ADJ=3.3V$ (duty 100%)
		--	350	--	mA	$V_{LED}=12V$ $ADJ=3.3V$ (duty 100%)
ADJ Input Voltage	V_{ADJ}	3.3	--	5	V	duty=100% Note(3)
LED voltage	V_{AK}	15.5	16.5	17.5	V	Note(1)
LED forward Current	I_{AK}	--	180	--	mA	$T_a=25^{\circ}C$
LED life time	--	--	30,000	--	Hr	Note(2)

Note (1) The constant current source is needed for white LED back-light driving.

When LCM is operated over 60 deg.C ambient temperature, the I_{LED} of the LED back-light should be adjusted .

Note (2) Brightness to be decreased to 50% of the initial value.

Note (3) V_{LEDADJ} is PWM signal input. It is for brightness control.

There are 3 Groups LED shown as below , $V_{AK} = 16.5V$, $I_{AK} = 180mA$.

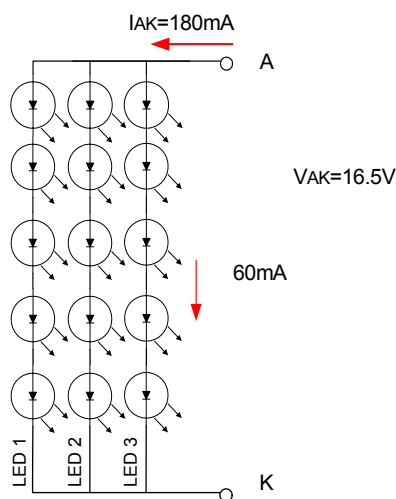

Brightness to be decreased to 50% of the initial value.

Preliminary

The contents of this document are confidential and must not be disclosed wholly or in part to any third part without the prior written consent of AMPIRE CO., LTD

4-3 Power Sequence

a. Power on:

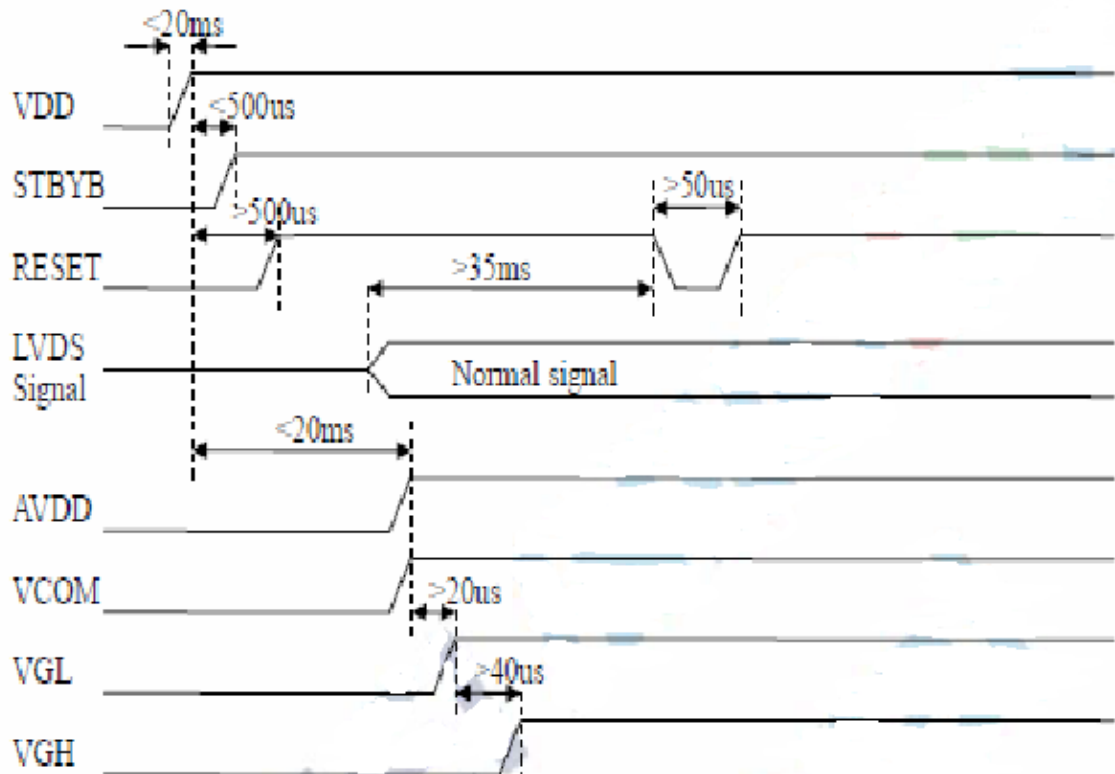

b. Power off:

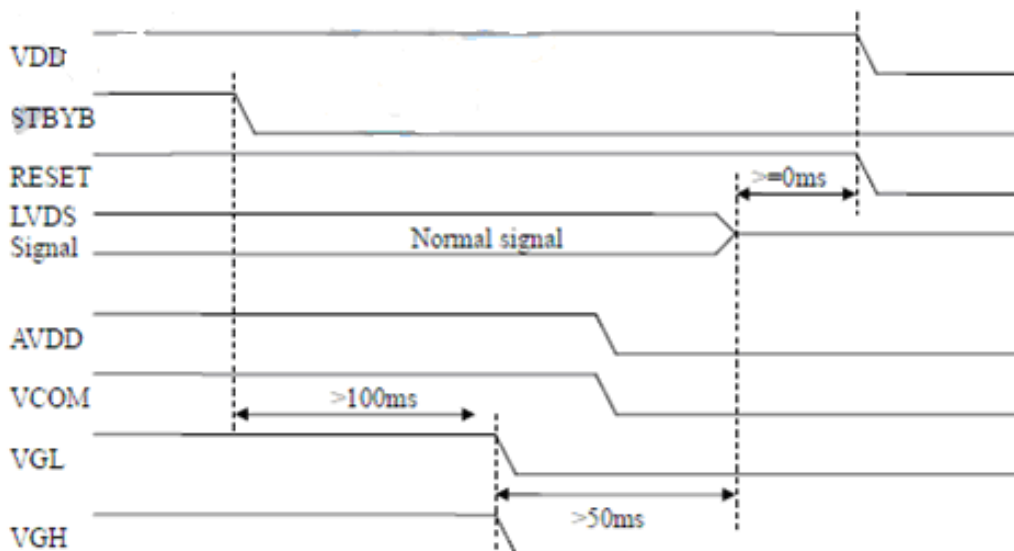

Preliminary

The contents of this document are confidential and must not be disclosed wholly or in part to any third part without the prior written consent of AMPIRE CO., LTD

5. Optical Specifications

Item	Symbol	Condition	Values			Unit	Note
			Min.	Typ.	Max.		
Viewing angle ($CR \geq 10$)	θL	$\Phi = 180^\circ$ (9 o'clock)	65	75	--	degree	Note1
	θR	$\Phi = 0^\circ$ (3 o'clock)	65	75	--		
	θT	$\Phi = 90^\circ$ (12 o'clock)	65	70	--		
	θB	$\Phi = 270^\circ$ (6 o'clock)	65	75	--		
Response time	TON	Normal $\theta = \Phi = 0^\circ$	--	10	20	msec	Note3
	TOFF		--	15	30	msec	
Contrast ratio	CR		500	700	--	--	Note4
Color chromaticity	WX		0.249	0.299	0.349	--	Note5
	WY		0.273	0.323	0.373	--	Note6
Luminance	L		400	500	--	cd/m ²	Note6
Transmittance	Tr		--	3.5	--	%	

Test Conditions:

1. Vled = 12V, IL = 240mA (Backlight current), the ambient temperature is 25°C.
2. The test systems refer to Note 2.

Preliminary

The contents of this document are confidential and must not be disclosed wholly or in part to any third part without the prior written consent of AMPIRE CO., LTD

Note 1 : Definition of viewing angle range

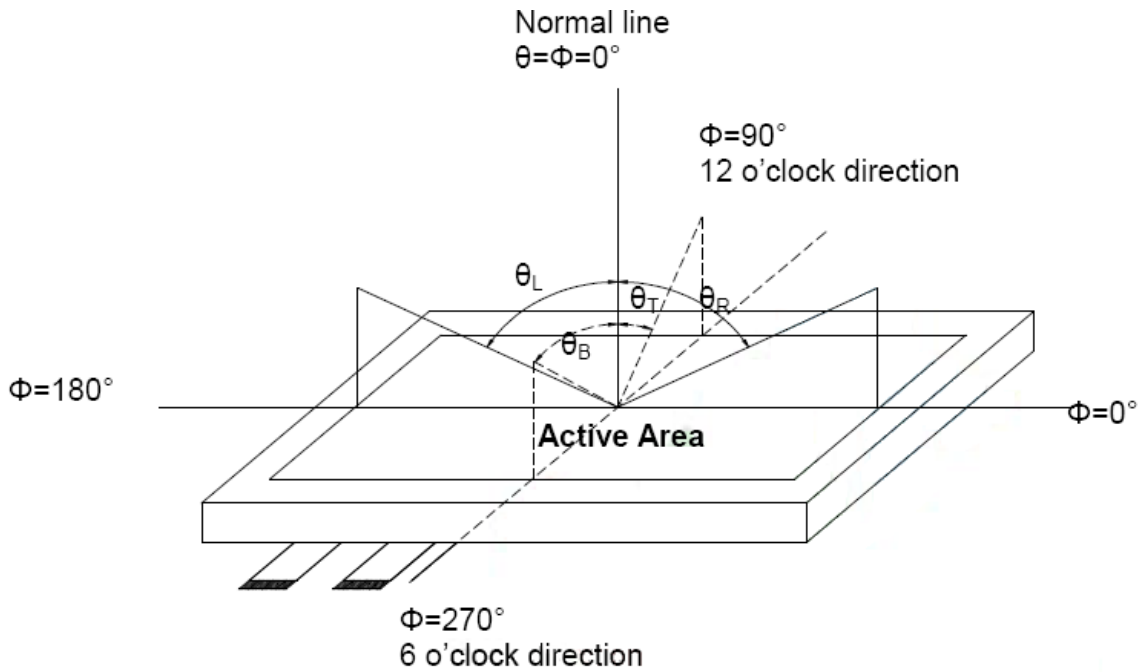

Note 2 : Definition of optical measurement system.

The optical characteristics should be measured in dark room. After 30 minutes operation, the optical properties are measured at the center point of the LCD screen. (Response time is measured by Photo detector TOPCON BM-7, other items are measured by BM-5A/Field of view : 1° / Height : 500mm.)

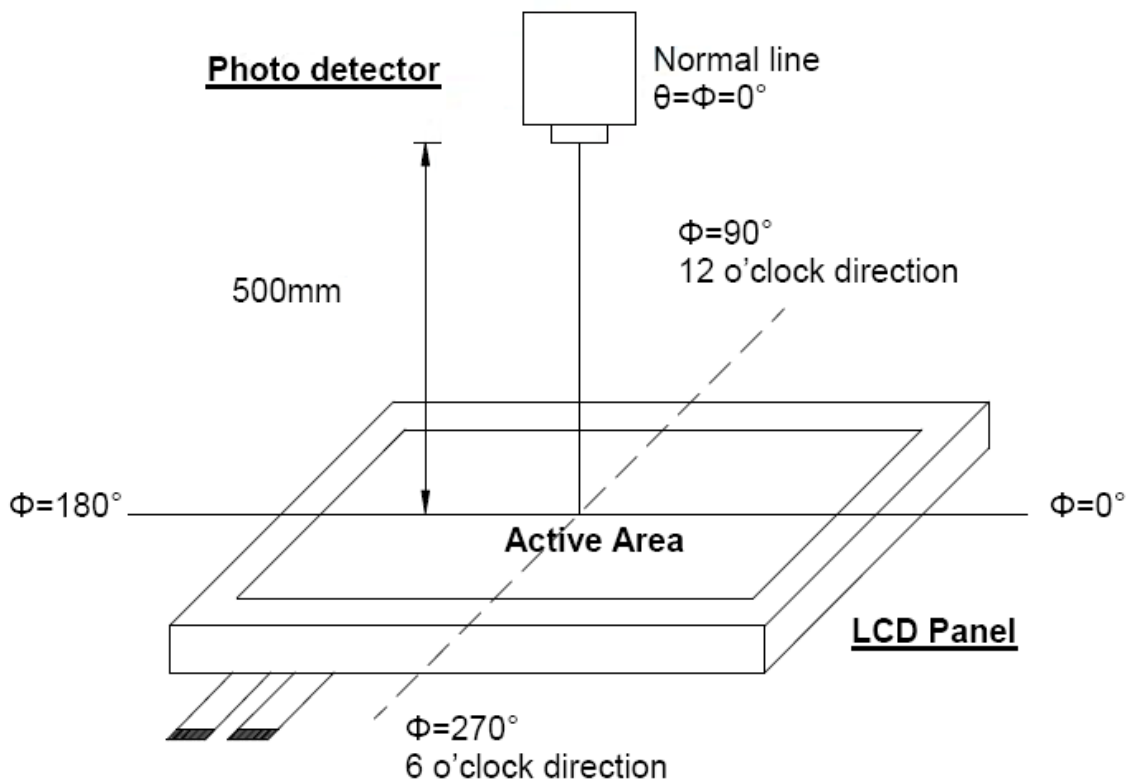

Preliminary

The contents of this document are confidential and must not be disclosed wholly or in part to any third part without the prior written consent of AMPIRE CO., LTD

Note 3 : Definition of Response time

The response time is defined as the LCD optical switching time interval between “White” state and “Black” state. Rise time (T_{ON}) is the time between photo detector output intensity changed from 90% to 10%. And fall time (T_{OFF}) is the time between photo detector output intensity changed from 10% to 90%.

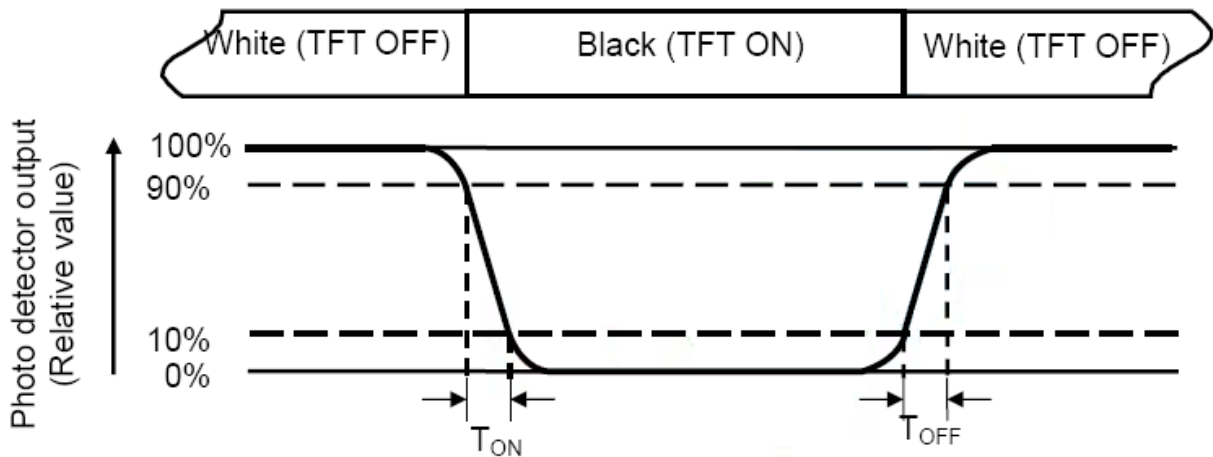

Note 4 : Definition of contrast ratio

$$\text{Contrast ratio (CR)} = \frac{\text{Luminance measured when LCD on the "White" state}}{\text{Luminance measured when LCD on the "Black" state}}$$

Note 5 : Definition of color chromaticity (CIE1931)

Color coordinated measured at center point of LCD.

Note 6 : All input terminals LCD panel must be ground when measuring the center area of the panel.

Preliminary

The contents of this document are confidential and must not be disclosed wholly or in part to any third part without the prior written consent of AMPIRE CO., LTD

6. INTERFACE

TFT LCD Panel Driving Section

Pin No.	Symbol	I/O	Description	Note
1	VDD	P	Power Voltage for Logic: 3.3V	
2	VDD	P	Power Voltage for Logic: 3.3V	
3	U/D	I	Vertical Reverse Scan Control	
4	L/R	I	Horizontal Reverse Scan Control.	
5	IN0-	I	- LVDS differential data input	
6	IN0+	I	+ LVDS differential data input	
7	GND	P	Ground	
8	IN1-	I	- LVDS differential data input	
9	IN1+	I	+ LVDS differential data input	
10	GND	P	Ground	
11	IN2-	I	- LVDS differential data input	
12	IN2+	I	+ LVDS differential data input	
13	GND	P	Ground	
14	CLK-	I	- LVDS differential data input	
15	CLK+	I	+ LVDS differential data input	
16	GND	P	Ground	
17	IN3-	I	- LVDS differential data input	
18	IN3+	I	+ LVDS differential data input	
19	VLED	P	Power supply for backlight: 5V OR 12V	
20	LEDADJ	I	LED PWM signal	

I : input, O : output, P : power

Preliminary

The contents of this document are confidential and must not be disclosed wholly or in part to any third part without the prior written consent of AMPIRE CO., LTD

NOTE :

(1) Pin3: ADJ is PWM signal input. It is for brightness control.

ITEM	SYMBOL	MIN	TYP	MAX	UNIT
ADJ signal frequency	f _{PWM}	10	--	100	KHz
ADJ signal logic level High	VIH	2V	--	VLED (5.0V)	V
ADJ signal logic level Low	VIL	0	--	0.5	V

Preliminary

The contents of this document are confidential and must not be disclosed wholly or in part to any third part without the prior written consent of AMPIRE CO., LTD

7. TIMING CHARACTERISTICS

7-1 AC Electrical Characteristics

Parameter	Symbol	Values			Unit	Remark
		MIN	TYP	MAX		
Clock frequency	R_{xFCLK}	40.8	51.2	71		
Input data skew margin	T_{RSKM}	500	--	--		
Clock high time	T_{LVCH}	--	$4/(7 * R_{xFCLK})$	--		
Clock low time	T_{LVCL}	--	$3/(7 * R_{xFCLK})$	--		

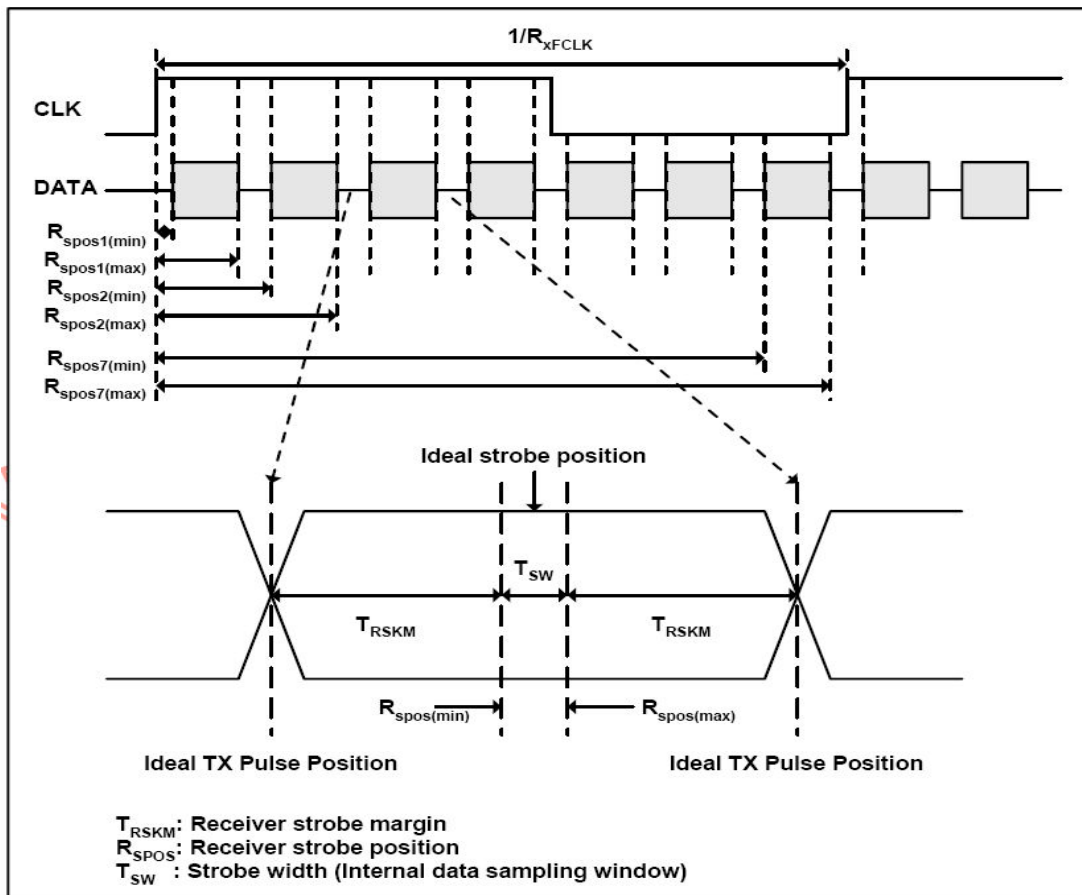
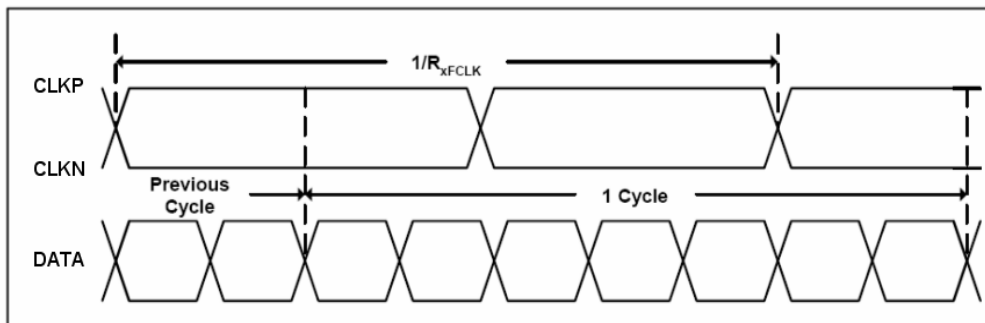

Preliminary

The contents of this document are confidential and must not be disclosed wholly or in part to any third part without the prior written consent of AMPIRE CO., LTD

7-2 DC Electrical Characteristics

Item	Symbol	Values			Unit	Note
		Min.	Typ.	Max.		
Differential input high Threshold voltage	R_{xVTH}	-	-	+0.1	V	$R_{xVCM}=1.2V$
Differential input low Threshold voltage	R_{xVTL}	-0.1	-	-	V	
Input voltage range (singled-end)	R_{xVIN}	0	-	2.4	V	
Differential input common mode voltage	R_{xVCM}	$ V_{ID} /2$	-	$2.4- V_{ID} /2$	V	
Differential voltage	$ V_{ID} $	0.2	-	0.6	V	
Differential input leakage current	$R_{V_{xIIZ}}$	-10	-	+10	μA	

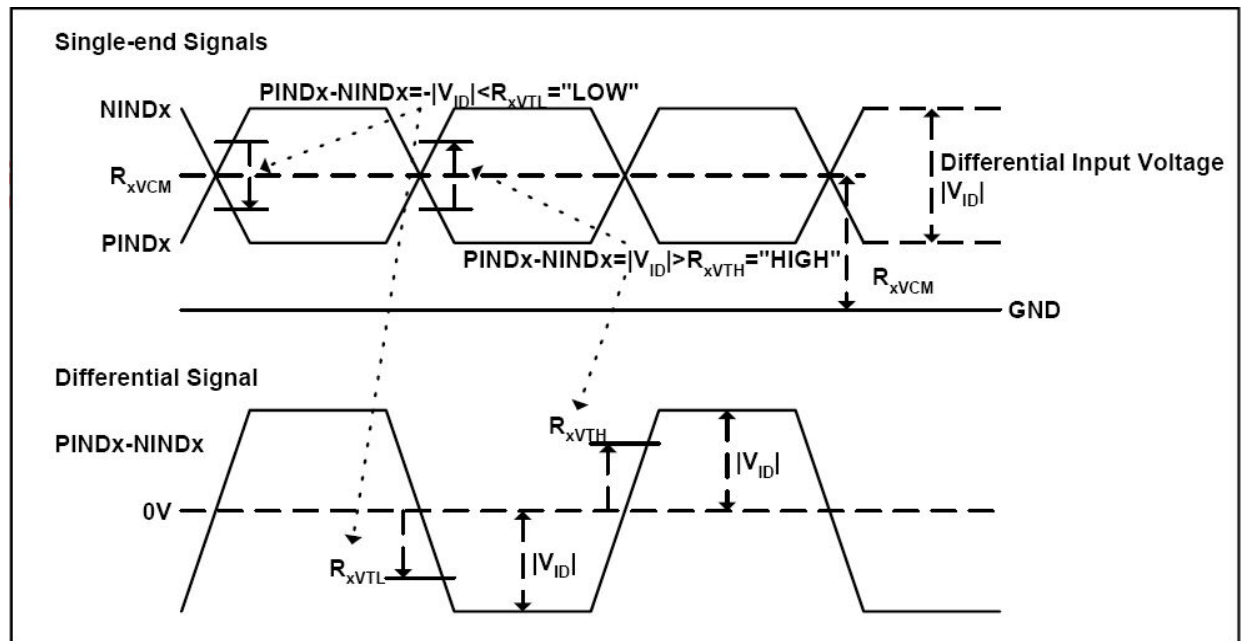

Preliminary

The contents of this document are confidential and must not be disclosed wholly or in part to any third part without the prior written consent of AMPIRE CO., LTD

7-3 Timing

Item	Symbol	Values			Unit	Note
		Min.	Typ.	Max.		
Clock Frequency	fclk	40.8	51.2	67.2	MHz	Frame rate =60Hz
Horizontal display area	thd	1024			DCLK	
HS period time	th	1114	1344	1400	DCLK	
HS Blanking	thb	90	320	376	DCLK	
Vertical display area	tvd	600			H	
VS period time	tv	610	635	800	H	
VS Blanking	thb	10	35	200	H	

Preliminary

The contents of this document are confidential and must not be disclosed wholly or in part to any third part without the prior written consent of AMPIRE CO., LTD

6bit LVDS input

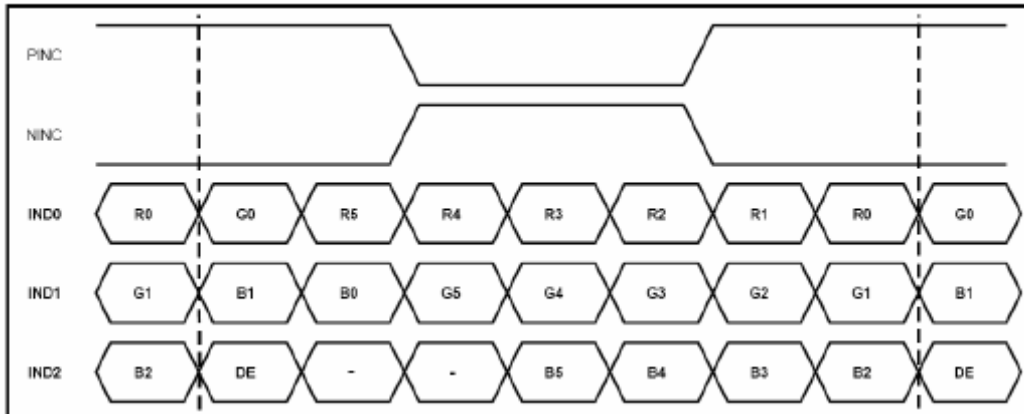

8bit LVDS input

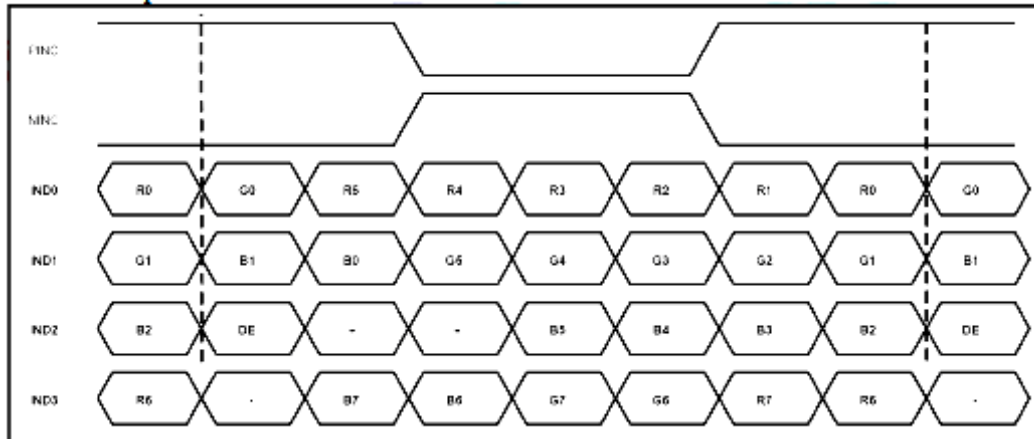

Preliminary

The contents of this document are confidential and must not be disclosed wholly or in part to any third part without the prior written consent of AMPIRE CO., LTD

8. RELIABILITY TEST CONDITIONS

(Note 3)

Item	Test Conditions	Note
High Temperature Storage	Ta = 80°C 240 hrs	Note 1,4
Low Temperature Storage	Ta = -30°C 240 hrs	Note 1,4
High Temperature Operation	Ts = 70°C 240 hrs	Note 2,4
Low Temperature Operation	Ta = -20°C 240 hrs	Note 1,4
Operate at High Temperature and Humidity	+60°C, 90%RH 240 hrs	
Thermal Shock	-30°C /30 min ~ +80°C /30 min for a total 100 cycles, Start with cold temperature and end with high temperature	

Note 1 : Ta is the ambient temperature of samples.

Note 2 : Ts is the temperature of panel's surface.

Note 3 : In the standard condition, there shall be no practical problem that may affect the display function. After the reliability test, the product only guarantees operation, but don't guarantee all of the cosmetic specification.

Note 4 : Before cosmetic and function test, the product must have enough recovery time, at least 2 hours at room temperature.

Preliminary

The contents of this document are confidential and must not be disclosed wholly or in part to any third part without the prior written consent of AMPIRE CO., LTD

8.1. Scope

Specifications contain

8.1.1 Display Quality Evaluation

8.1.2 Mechanics Specification

8.2. Sampling Plan

Unless there is other agreement, the sampling plan for incoming inspection shall follow MIL-STD-105E LEVEL II.

8.2.1 Lot size: Quantity per shipment as one lot (different model as different lot).

8.2.2 Sampling type: Normal inspection, single sampling.

8.2.3 Sampling level: Level II.

8.2.4 AQL: Acceptable Quality Level

Major defect: AQL=0.65

Minor defect: AQL=1.0

8.3. Panel Inspection Condition

8.3.1 Environment:

Room Temperature: $25\pm 5^{\circ}\text{C}$.

Humidity: $65\pm 5\%$ RH.

Illumination: 300 ~ 700 Lux.

8.3.2 Inspection Distance:

35-40 cm

8.3.3 Inspection Angle:

The vision of inspector should be perpendicular to the surface of the Module.

8.3.4 Inspection time :

Perceptibility Test Time: 20 seconds max.

8.4. Display Quality

8.4.1 Function Related:

The function defects of line defect, abnormal display, and no display are considered Major defects.

8.4.2 Bright/Dark Dots:

Preliminary

The contents of this document are confidential and must not be disclosed wholly or in part to any third part without the prior written consent of AMPIRE CO., LTD

Defect Type / Specification	G0 Grade	A Grade
Bright Dots	0	$N \leq 2$
Dark Dots	0	$N \leq 3$
Total Bright and Dark Dots	0	$N \leq 4$

[Note 1]

Judge defect dot and adjacent dot as following.

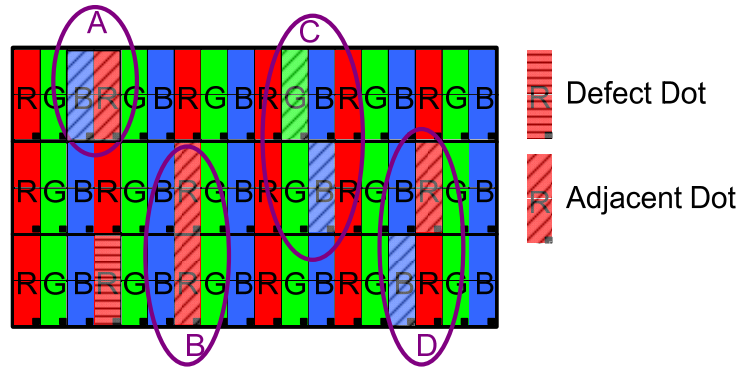

- (1) One pixel consists of 3 sub-pixels, including R,G, and B dot.(Sub-pixel = Dot)
- (2) The definition of dot: The size of a defective dot over 1/2 of whole dot is regarded as one defective dot.
- (3) Allow above (as A, B, C and D status) adjacent defect dots, including bright and dart adjacent dot. And they will be counted 2 defect dots in total quantity.
- (4) Defects on the Black Matrix, out of Display area, are not considered as a defect or counted.
- (5) There should be no distinct non-uniformity visible through 6% ND Filter within 2 sec inspection times.
- (6) 4.3 Visual Inspection specifications:

Defect Type	Specification	Count(N)
Dot Shape (Particle, Scratch and Bubbles in display area)	$D \leq 0.2\text{mm}$	Ignored
	$0.2\text{mm} < D \leq 0.4\text{mm}$	$N \leq 3$
	$D > 0.4\text{mm}$	$N=0$
Line Shape (Particles, Scratch, Lint and Bubbles in display area)	$W \leq 0.05\text{mm}$	Ignored
	$0.05\text{mm} < W \leq 0.1\text{mm}$, $L \leq 4\text{mm}$	$N \leq 3$
	$W > 0.1\text{mm}$, $L > 4\text{mm}$	$N=0$

[Note 2] W : Width[mm], L : Length[mm], N : Number, ϕ : Average Diameter

Preliminary

The contents of this document are confidential and must not be disclosed wholly or in part to any third part without the prior written consent of AMPIRE CO., LTD

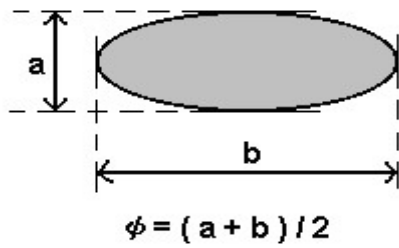

1. (White, black) Spot
2. Polarizer Bubble

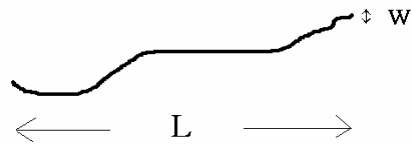

[Note 3] Bright dot is defined through 6% transmission ND Filter as following.

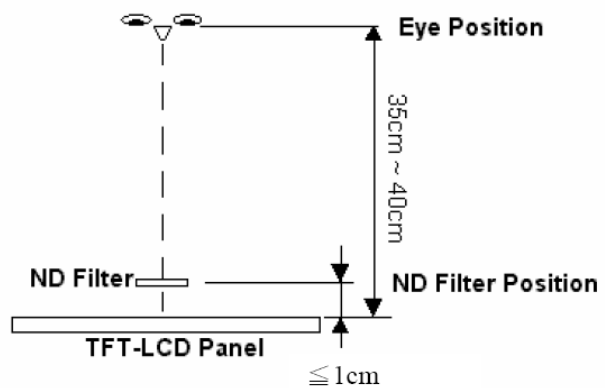
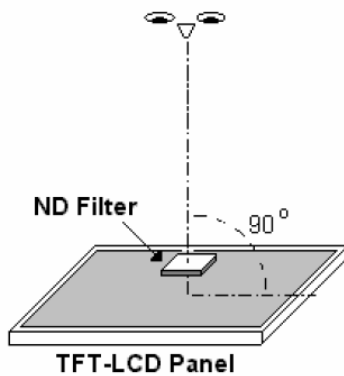
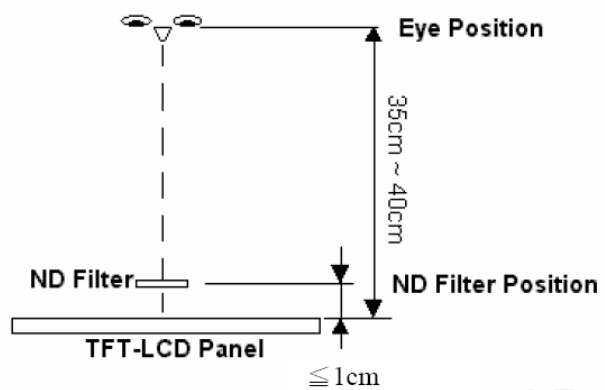
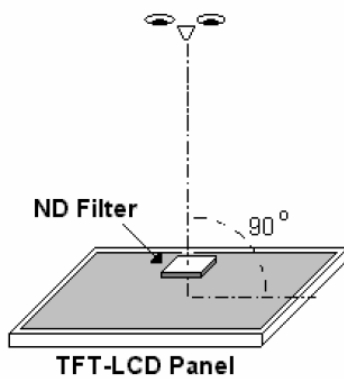

[Note3]

- C Area: Center of display area
- C Area: Outer of display area

Preliminary

The contents of this document are confidential and must not be disclosed wholly or in part to any third part without the prior written consent of AMPIRE CO., LTD

9. General Precautions

9-1 Safety

Liquid crystal is poisonous. Do not put it your mouth. If liquid crystal touches your skin or clothes, wash it off immediately by using soap and water.

9-2 Handling

1. The LCD panel is plate glass. Do not subject the panel to mechanical shock or to excessive force on its surface.
2. The polarizer attached to the display is easily damaged. Please handle it carefully to avoid scratch or other damages.
3. To avoid contamination on the display surface, do not touch the module surface with bare hands.
4. Keep a space so that the LCD panels do not touch other components.
5. Put cover board such as acrylic board on the surface of LCD panel to protect panel from damages.
6. Transparent electrodes may be disconnected if you use the LCD panel under environmental conditions where the condensation of dew occurs.
7. Do not leave module in direct sunlight to avoid malfunction of the ICs.

9-3 Static Electricity

1. Be sure to ground module before turning on power or operation module.
2. Do not apply voltage which exceeds the absolute maximum rating value.

9-4 Storage

1. Store the module in a dark room where must keep at $+25\pm 10^{\circ}\text{C}$ and 65%RH or less.
2. Do not store the module in surroundings containing organic solvent or corrosive gas.
3. Store the module in an anti-electrostatic container or bag.

9-5 Cleaning

1. Do not wipe the polarizer with dry cloth. It might cause scratch.
2. Only use a soft sloth with IPA to wipe the polarizer, other chemicals might permanent damage to the polarizer.

9-5 Others

1. AMIPRE will provide one year warrantee for all products and three months warrantee for all repairing products.

Preliminary

The contents of this document are confidential and must not be disclosed wholly or in part to any third part without the prior written consent of AMPIRE CO., LTD

10. OUTLINE DIMENSION

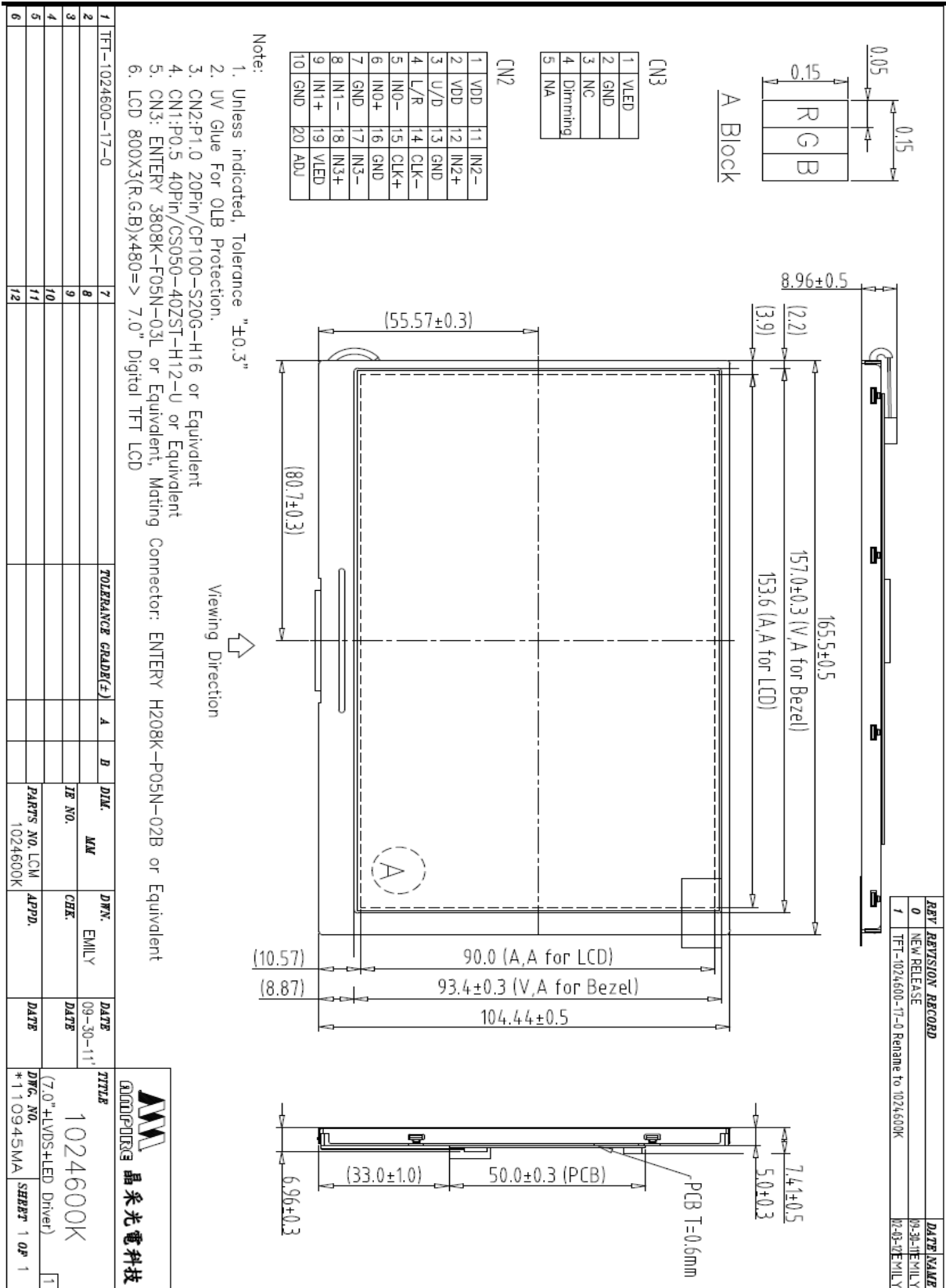

Preliminary

The contents of this document are confidential and must not be disclosed wholly or in part to any third part without the prior written consent of AMPIRE CO., LTD

