





晶采光電科技股份有限公司
AMPIRE CO., LTD.

SPECIFICATIONS FOR LCD MODULE

CUSTOMER	
CUSTOMER PART NO.	
AMPIRE PART NO.	AM-800600P6TMQW-TA7H
APPROVED BY	
DATE	

- Approved For Specifications
 Approved For Specifications & Sample

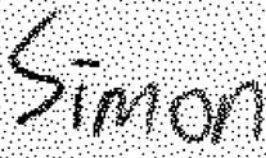
AMPIRE CO., LTD.
4F., No.116, Sec. 1, Xintai 5th Rd., Xizhi Dist., New Taipei City 221,
Taiwan (R.O.C.)
22181 新北市 汐止區 新台五路一段 116 號 4 樓(東方科學園區 A 棟)
TEL:886-2-26967269 , FAX:886-2-26967196 or 26967270

APPROVED BY	CHECKED BY	ORGANIZED BY
		

RECORD OF REVISION

Revision Date	Page	Contents	Editor
2013/10/15	--	New Release	Simon

1. Features

8 inch Amorphous-TFT-LCD (Thin Film Transistor Liquid Crystal Display) module. This module is composed of a 8" TFT-LCD panel, LED backlight and power circuit unit.

- (1) Construction: 8" a-Si TFT active matrix, White LED Backlight, power circuit Board and Touch panel.
- (2) Resolution (pixel): 800(R.G.B) X600
- (3) Number of the Colors : 262K colors (R , G , B 6 bit digital each)
- (4) LCD type : Transmissive , normally White
- (5) Interface: 20 Pin (LVDS interface)
- (6) Power Supply Voltage: 3.3V for logic voltage, 12V for LED driver power voltage.
- (7) Viewing Direction: 6 O'clock (The direction it's hard to be discolored)

2. PHYSICAL SPECIFICATIONS

Item	Specifications	unit
LCD size	8 inch (Diagonal)	
Resolution	800 x 3(RGB) x 600	dot
Dot pitch	0.0675(W) x 0.2025(H)	mm
Active area	162.0(W) x 121.5(H)	mm
Module size	200.4(W) x 141.0(H) x 10.35(D)	mm
Surface treatment	Anti-Glare	
Color arrangement	RGB-stripe	
interface	Digital	
Weight	350	g

3. ABSOLUTE MAX. RATINGS

Item	Symbol	Values		UNIT	Note
		Min.	Max.		
Power voltage	VCC	-0.5	5	V	
	VLED	-0.5	18		
Input signal voltage	Vi	-0.3	VCC+0.3	V	Note 1
Operation temperature	TOP	-20	70	°C	
Storage temperature	TST	-30	80	°C	

Note 1: The product is subject to be damaged permanently if stresses beyond those absolute maximum ratings listed above.

4. ELECTRICAL CHARACTERISTICS

4-1 TFT LCD Module

		MIN	NOM	MAX	UNIT
V_{CC}	Supply voltage	3	3.3	3.6	V
V_{IH}	High-level input voltage (\overline{SHTDN})	2			V
V_{IL}	Low-level input voltage (\overline{SHTDN})			0.8	V
$ V_{ID} $	Magnitude differential input voltage	0.1		0.6	V
V_{IC}	Common-mode input voltage	$\frac{ V_{ID} }{2}$		$2.4 - \frac{ V_{ID} }{2}$	V

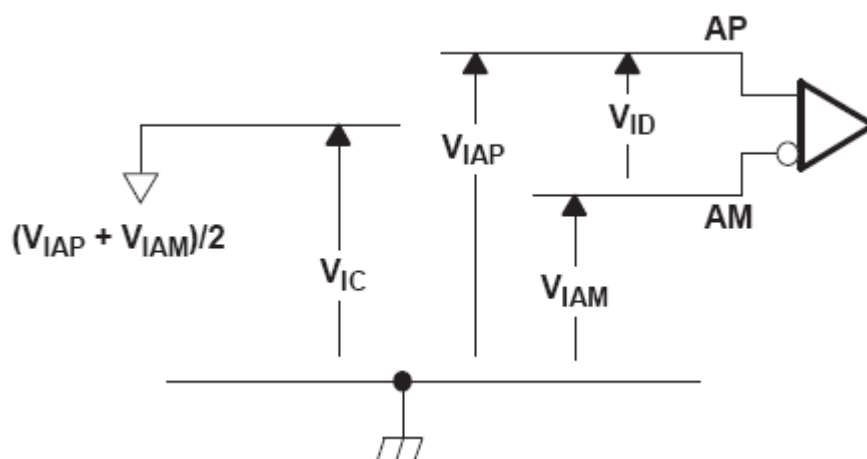

4-2 Backlight Driving Conditions

Item	Symbol	Values			Unit	Note
		Min.	Typ.	Max.		
LED Driver voltage	VLED	--	12	--	V	
Power Supply Current For LED Driver	ILED	-	640	-	mA	VLED=12V VADJ=3.3V (duty 100%)
ADJ Input Voltage	V _{ADJ}	-	3.3	5	V	duty=100% Note(3)
LED voltage	V _{AK}	--	19.8	--	V	I _L =320mA Ta=25°C
LED current	I _L	324	320	396	mA	Ta=25°C
		--	270	--	mA	Ta=60°C
LED Life Time	-	--	50K	--	Hour	Note (2)

Note (1) The constant current source is needed for white LED back-light driving. When LCM is operated over 60 deg.C ambient temperature, the I_L of the LED back-light should be adjusted to 270mA max

Note (2) Brightness to be decreased to 50% of the initial value.

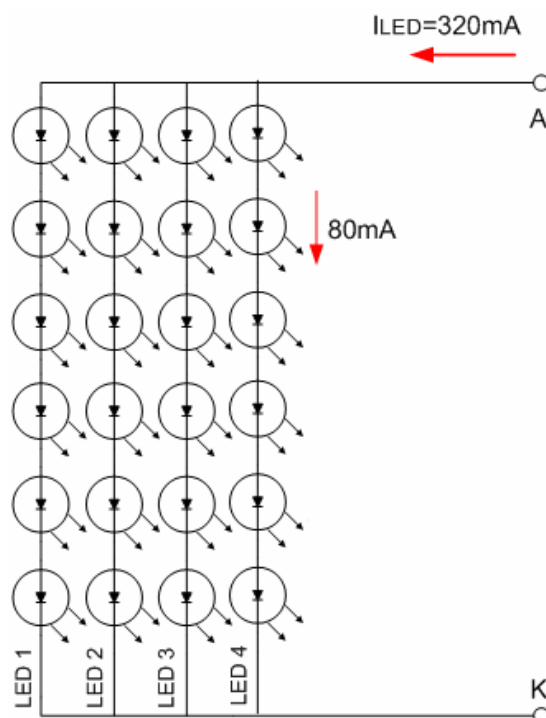

When LCM is operated over 40°C ambient temperature, the ILED should be follow :

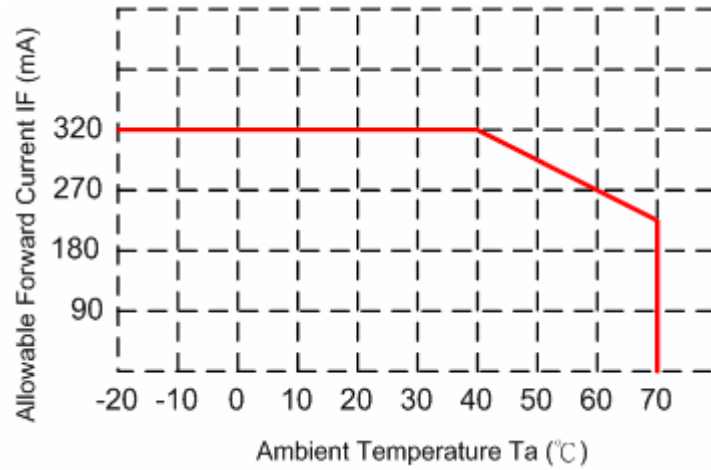

Note (3) VLEDADJ is PWM signal input. It is for brightness control.

ITEM	SYMBOL	MIN	TYP	MAX	UNIT
ADJ signal frequency	f_{PWM}	5K	20K	100K	Hz
ADJ signal logic level High	VIH	2.4	3.3	5.0	V
ADJ signal logic level Low	VIL	0	--	0.8	V

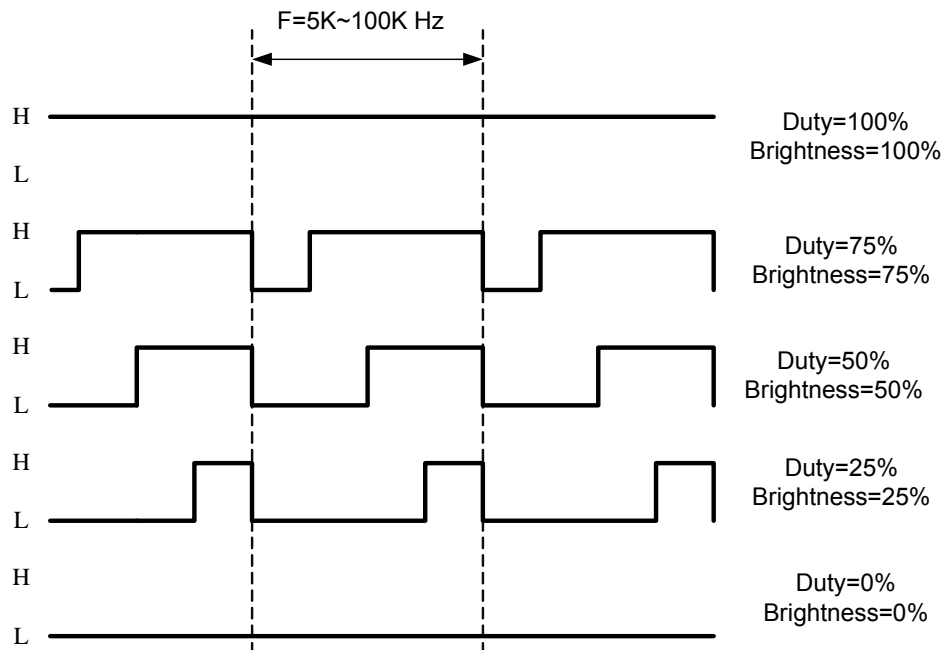

4-3 Power Sequence

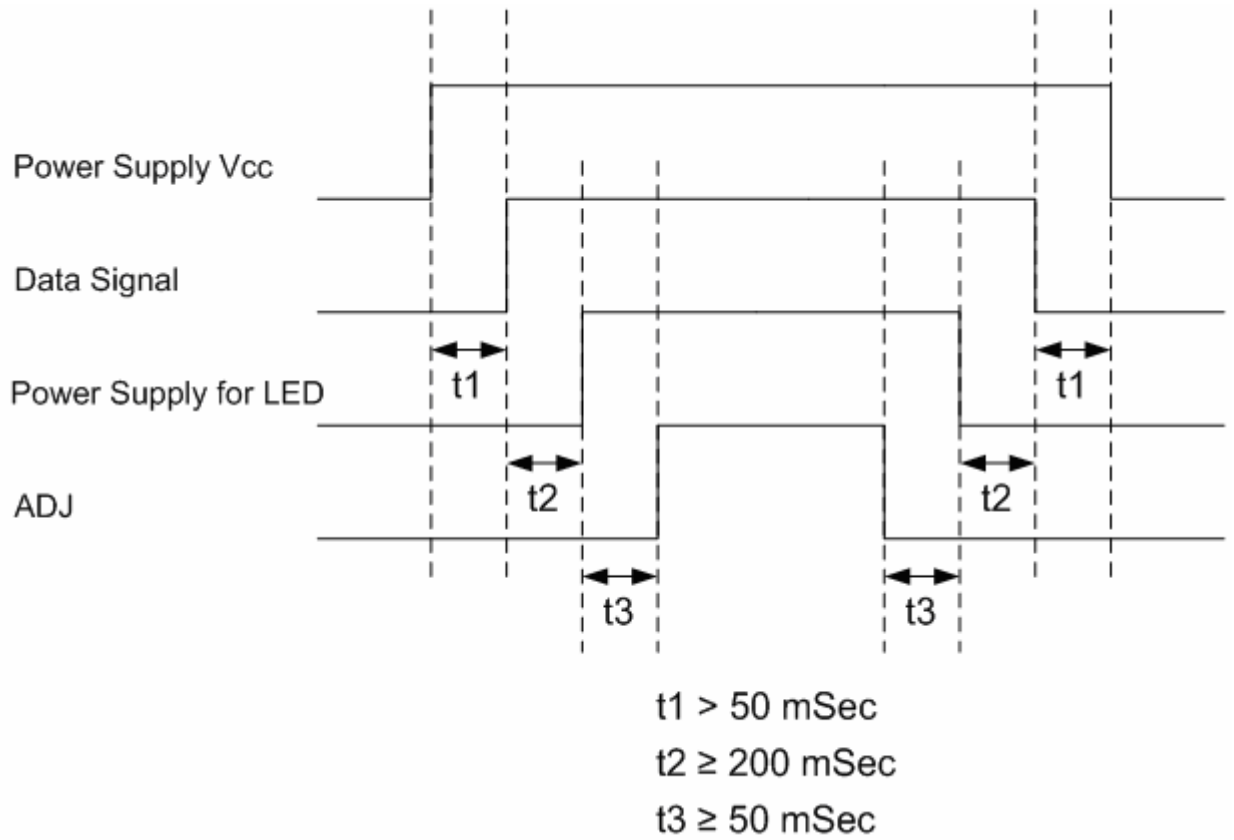

4-4 Block Diagram

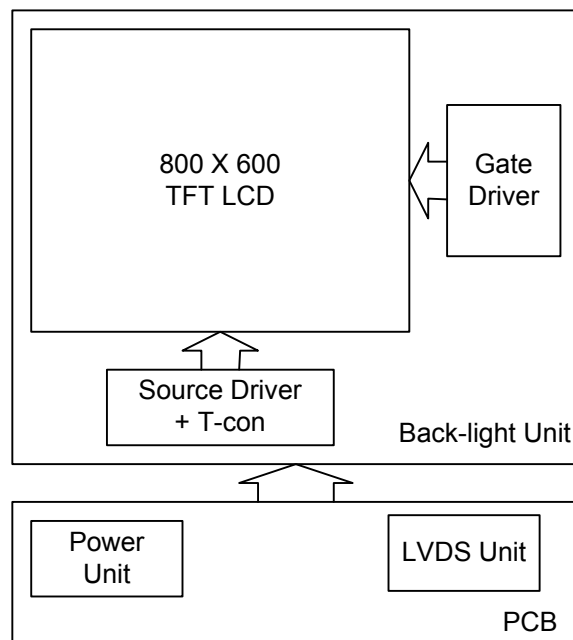

5. Optical Specifications

Item	Symbol	Condition	Values			Unit	Note
			Min.	Typ.	Max.		
Viewing angle (CR \geq 10)	θ L	$\Phi = 180^\circ$ (9 o'clock)	60	70	--	degree	Note1
	θ R	$\Phi = 0^\circ$ (3 o'clock)	60	70	--		
	θ T	$\Phi = 90^\circ$ (12 o'clock)	40	50	--		
	θ B	$\Phi = 270^\circ$ (6 o'clock)	60	70	--		
Response time	TON	Normal $\theta = \Phi = 0^\circ$	--	10	20	msec	Note3
	TOFF		--	15	30	msec	
Contrast ratio	CR		400	500	--	--	Note4
Color chromaticity	Rx		0.578	0.628	0.678	--	Note5 Note6
	Ry		0.294	0.344	0.394		
	Gx		0.289	0.339	0.389		
	Gy		0.538	0.588	0.538		
	Bx		0.104	0.154	0.204		
	By		0.081	0.131	0.181		
	Wx		0.26	0.31	0.36		
	Wy	0.28	0.33	0.38	--		
Luminance	L	640	800	--	cd/m ²	Note6	
Luminance uniformity	YU	70	75	--	%	Note7	

Test Conditions:

1. $V_{LED} = 12V$, $I_L = 320mA$ (Backlight current), the ambient temperature is $25^\circ C$.
2. The test systems refer to Note 2.

Note 1: Definition of viewing angle range

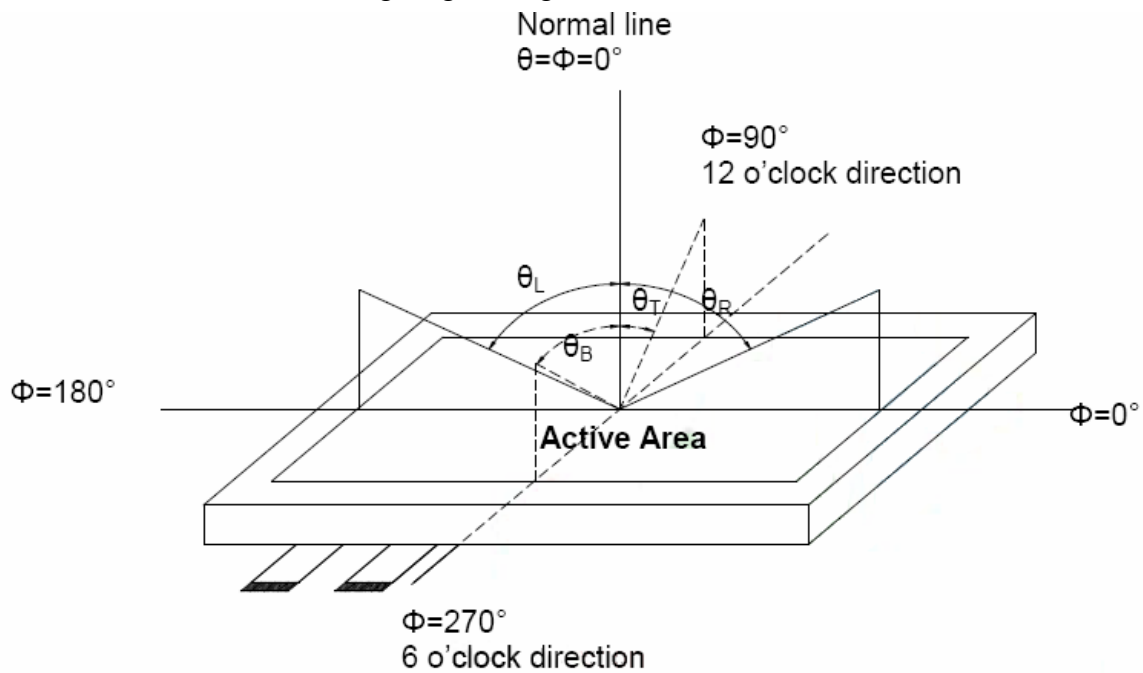

Note 2: Definition of optical measurement system.

The optical characteristics should be measured in dark room. After 30 minutes operation, the optical properties are measured at the center point of the LCD screen. (Response time is measured by Photo detector TOPCON BM-7, other items are measured by BM-5A/Field of view : 1° / Height : 500mm.)

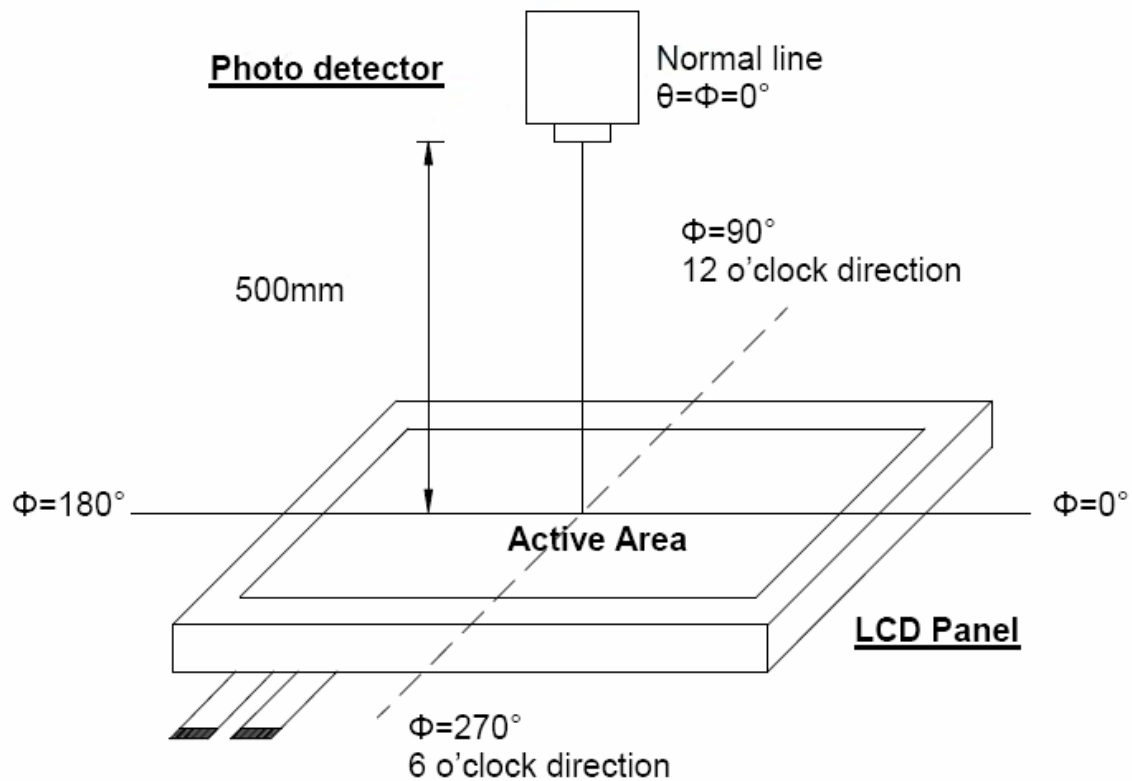

Note 3 : Definition of Response time

The response time is defined as the LCD optical switching time interval between “White” state and “Black” state. Rise time (T_{ON}) is the time between photo detector output intensity changed from 90% to 10%. And fall time (T_{OFF}) is the time between photo detector output intensity changed from 10% to 90%.

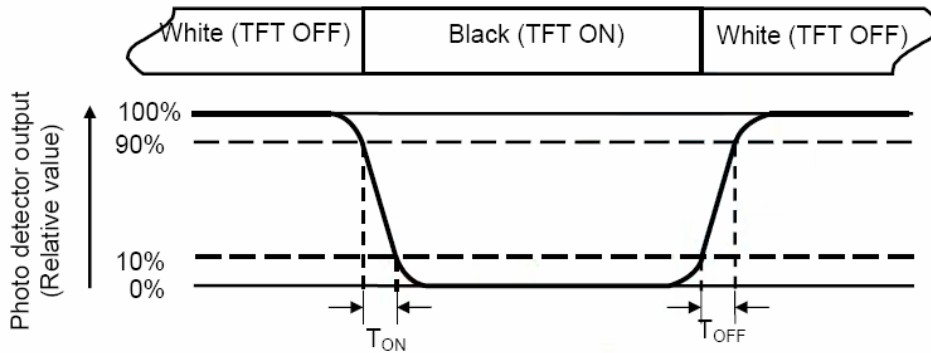

Note 4 : Definition of contrast ratio

$$\text{Contrast ratio (CR)} = \frac{\text{Luminance measured when LCD on the "White" state}}{\text{Luminance measured when LCD on the "Black" state}}$$

Note 5 : Definition of color chromaticity (CIE1931)

Color coordinated measured at center point of LCD.

Note 6 : All input terminals LCD panel must be ground when measuring the center area of the panel.

Note 7 : Definition of Luminance Uniformity

Active area is divided into 9 measuring areas (Refer to bellow figure). Every measuring point is placed at the center of each measuring area.

$$\Delta L = [L(\text{min.}) \text{ of } 9 \text{ points} / L(\text{max.}) \text{ of } 9 \text{ points}] \times 100\%$$

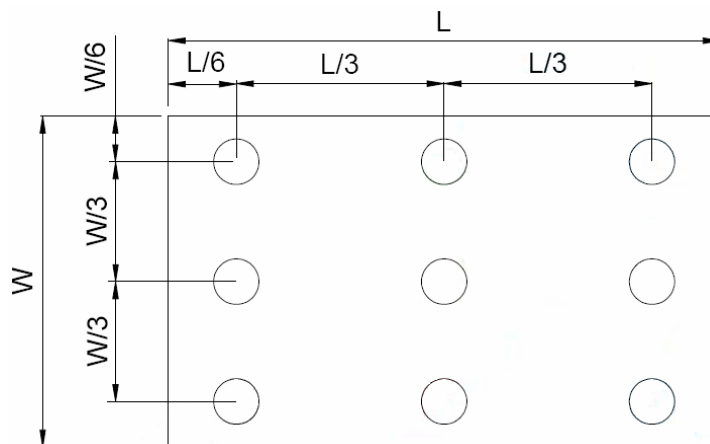

6. INTERFACE

TFT LCD Panel Driving Section

Pin No.	Symbol	Description	Note
1	VDD	POWER SUPPLY:3.3V	
2	VDD	POWER SUPPLY:3.3V	
3	GND	Power Ground	
4	GND	Power Ground	
5	IN0-	Transmission Data	
6	IN0+	Transmission Data	
7	GND	Power Ground	
8	IN1-	Transmission Data	
9	IN1+	Transmission Data	
10	GND	Power Ground	
11	IN2-	Transmission Data	
12	IN2+	Transmission Data	
13	GND	Power Ground	
14	CLK-	Sampling Clock	
15	CLK+	Sampling Clock	
16	GND	Power Ground	
17	VLED	POWER SUPPLY for Backlight : 12V	
18	VLED	POWER SUPPLY for Backlight : 12V	
19	GND	Power Ground	
20	ADJ	Adjust the LED brightness	

NOTE:

(1) Pin19: ADJ is PWM signal input. It is for brightness control.

ITEM	SYMBOL	MIN	TYP	MAX	UNIT
ADJ signal frequency	f_{PWM}	5K	20K	100K	Hz
ADJ signal logic level High	VIH	2.4	3.3	5.0	V
ADJ signal logic level Low	VIL	0	--	0.8	V

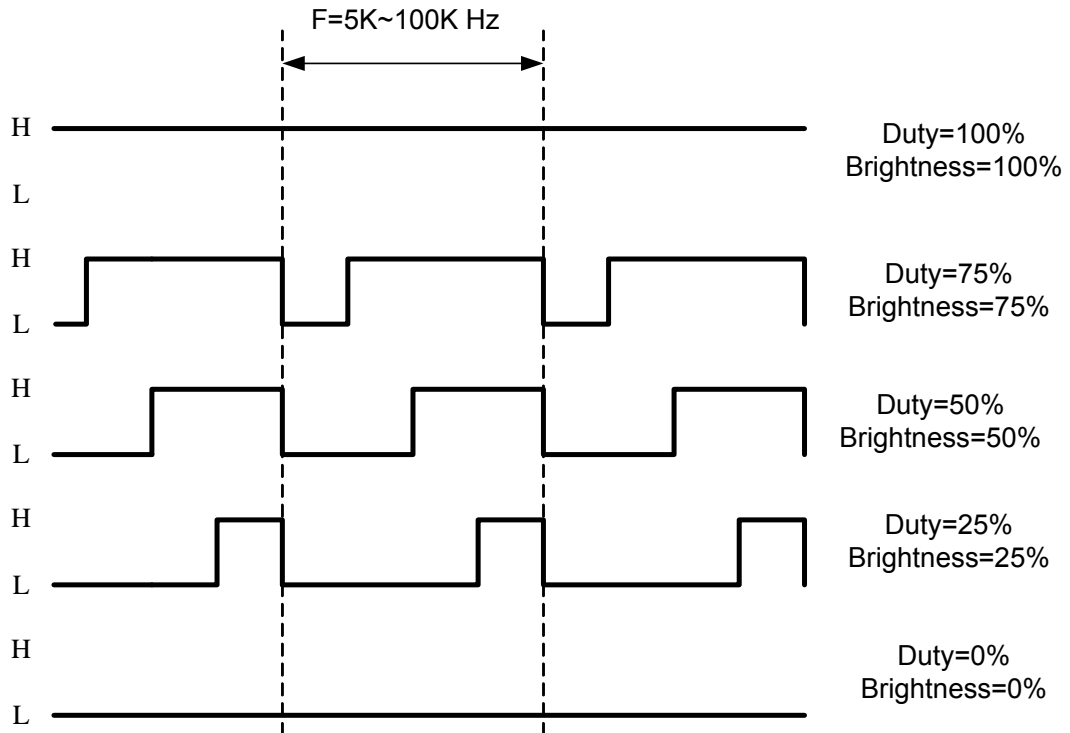

6.2 Touch Panel Electrical Specification

Parameter	Condition	Standard Value
Terminal Resistance	X Axis	300 ~ 1100 Ω
	Y Axis	150 ~ 650 Ω
Insulating Resistance	DC 25 V	More than 20M Ω
Linearity	--	± 1.5 %
Notes life by Pen	Note a	100,000 times(min)
Input life by finger	Note b	1,000,000 times (min)

Note A .

Notes area for pen notes life test is 10 x 9 mm.

Size of word is 7.5 x 6.75

Shape of pen end : R0.8

Load : 250 g

Note B

By Silicon rubber tapping at same point

Shape of rubber end : R8

Load : 200g

Frequency : 5 Hz

Interface

No.	Symbol	Function
1	Y1	Touch Panel Bottom Signal in Y Axis
2	X1	Touch Panel Left Signal in X Axis
3	Y2	Touch Panel Top Signal in Y Axis
4	X2	Touch Panel Right Signal in X Axis

7. INTERFACE TIMING (The information as below is to be defined.)

7-1 LVDS SIGNAL:

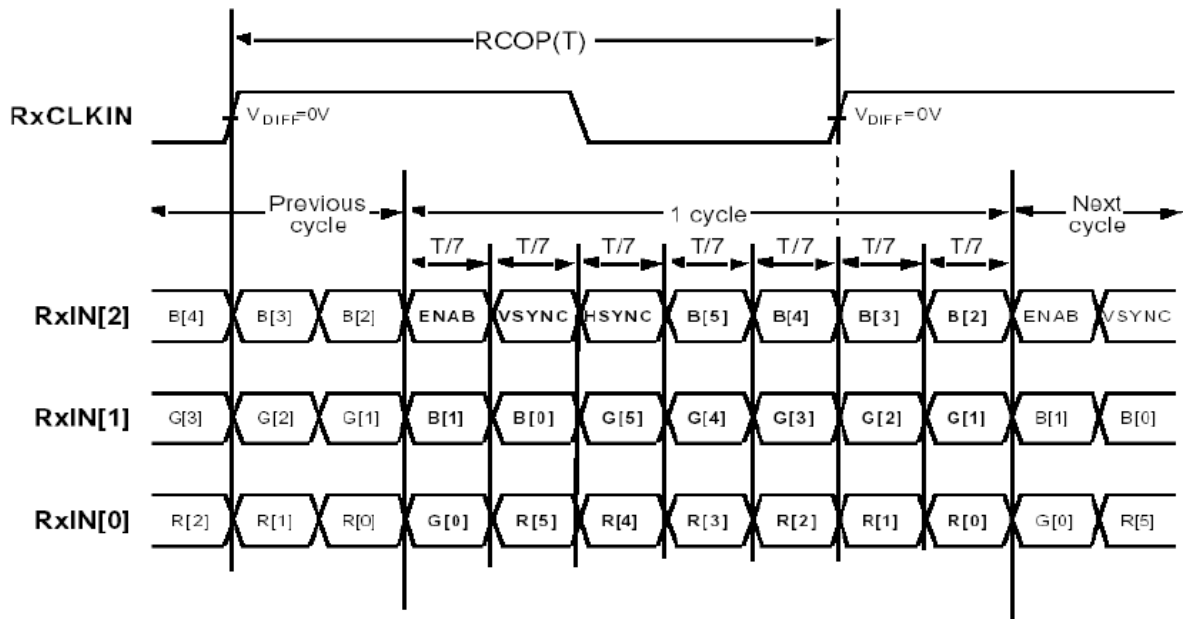

Note: R/G/B[5]s are MSBs and R/G/B[0]s are LSBs

7-2 LVDS AC Timing Diagram:

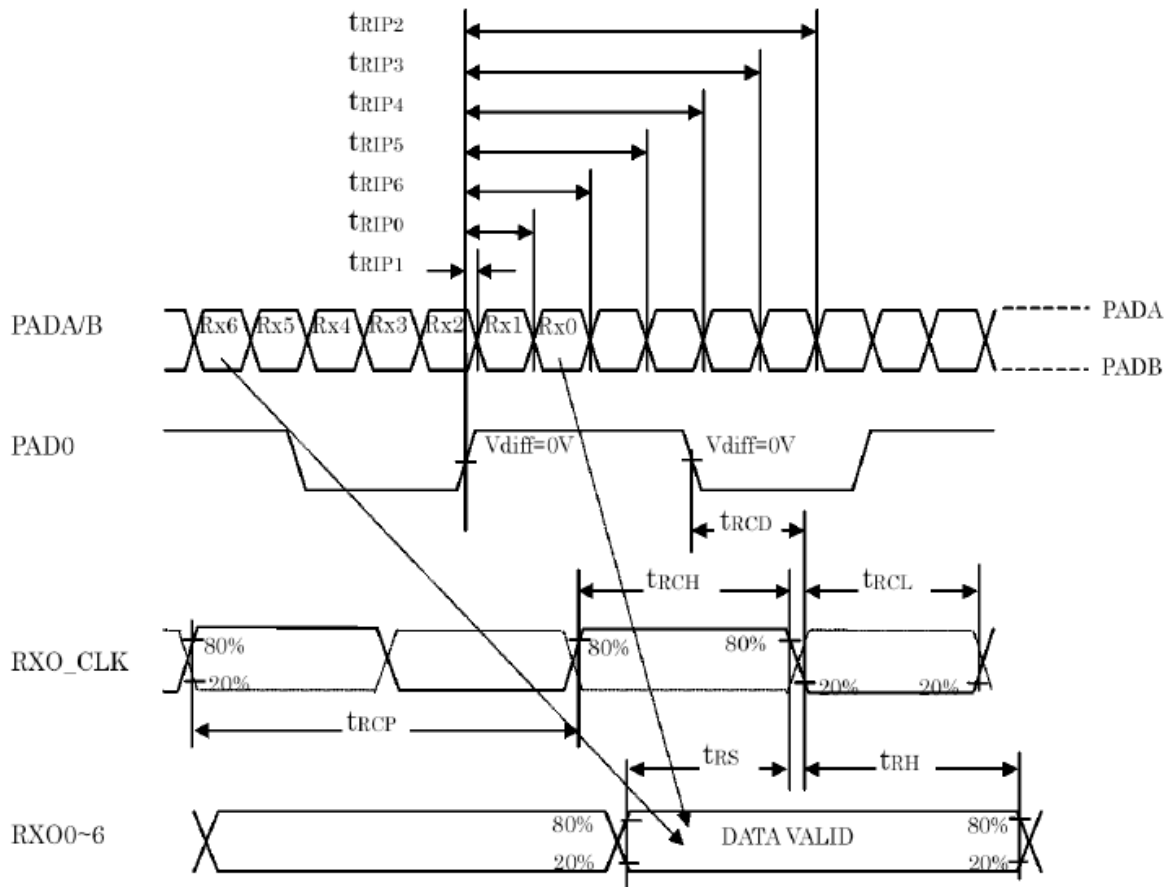

7-3 Phase Lock Loop Set Time:

(Case1)

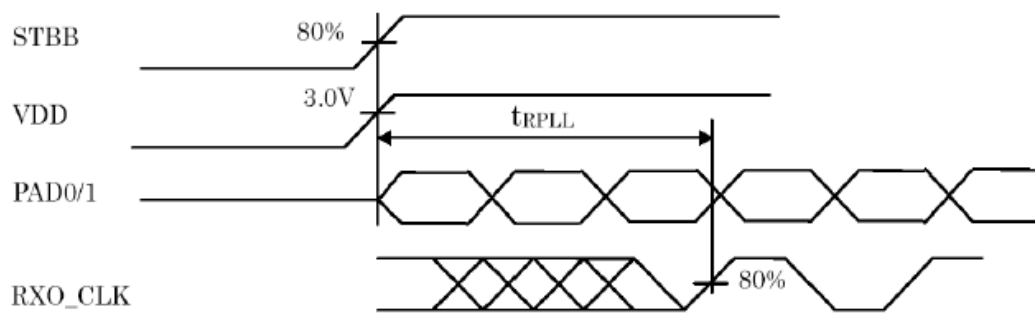

(Case2)

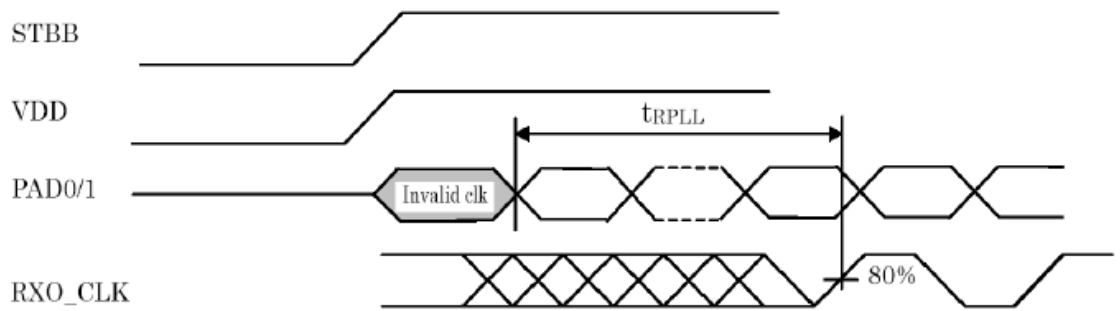

7-4 Recommended Input Timing of LVDS transmitter :

Item	Symbol	Values			Unit	Remark
		Min.	Typ.	Max.		
Horizontal Display Area	thd	-	800	-	DCLK	
DCLK Frequency	fclk	-	40	50	MHz	
One Horizontal Line	th	862	1056	1200	DCLK	
HS pulse width	thpw	1	-	40	DCLK	
HS Back Porch(Blanking)	thb	46	46	46	DCLK	
HS Front Porch	thfp	16	210	354	DCLK	

Item	Symbol	Values			Unit	Remark
		Min.	Typ.	Max.		
Vertical Display Area	tvd	-	600	-	TH	
VS period time	tv	624	635	700	TH	
VS pulse width	tvpw	1	-	20	TH	
VS Back Porch(Blanking)	tvb	23	23	23	TH	
VS Front Porch	tvfp	1	12	77	TH	

Horizontal input timing

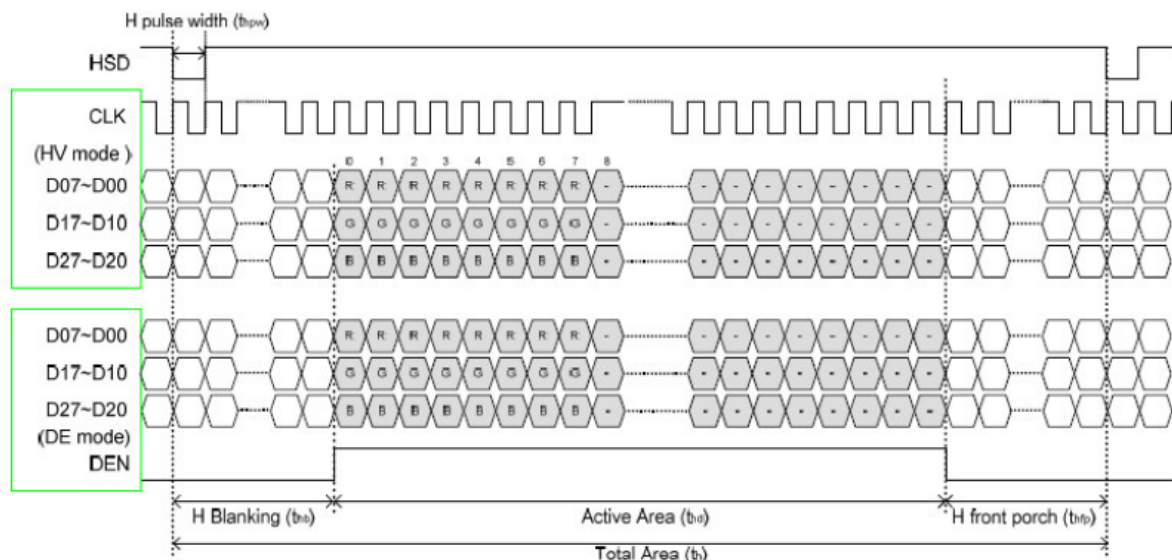

8. RELIABILITY TEST CONDITIONS

(Note 3)

Item	Test Conditions	Note
High Temperature Storage	Ta = 80°C 240 hrs	Note 1,4
Low Temperature Storage	Ta = -30°C 240 hrs	Note 1,4
High Temperature Operation	Ts = 70°C 240 hrs	Note 2,4
Low Temperature Operation	Ta = -20°C 240 hrs	Note1,4
Operate at High Temperature and Humidity	+60°C, 90%RH 240 hrs	
Thermal Shock	-30°C /30 min ~ +80°C /30 min for a total 100 cycles, Start with cold temperature and end with high temperature	
Vibration Test	Frequency range : 10 ~ 55Hz Stroke : 1.5mm Sweep : 10Hz ~ 55Hz ~ 10Hz 2 hours for each direction of X. Y. Z. (6 hours for total)	
Mechanical Shock	100G 6ms, ±X, ±Y, ±Z 3 times for each direction	
Package Vibration Test	Random Vibration : 0.015G*G/Hz from 5-200HZ, -6dB/Octave from 200-500Hz 2 hours for each direction of X. Y. Z. (6 hours for total)	
Package Drop Test	Height : 60 cm 1 comer, 3 edges, 6 surfaces	
Electro Static Discharge	±2KV, Human Body Mode, 100pF/1500Ω	

Note 1: Ta is the ambient temperature of samples.

Note 2: Ts is the temperature of panel's surface.

Note 3: In the standard condition, there shall be no practical problem that may affect the display function. After the reliability test, the product only guarantees operation, but don't guarantee all of the cosmetic specification.

Note 4: Before cosmetic and function test, the product must have enough recovery time, at least 2 hours at room temperature.

9. General Precautions

9-1 Safety

Liquid crystal is poisonous. Do not put it your month. If liquid crystal touches your skin or clothes, wash it off immediately by using soap and water.

9-2 Handling

1. The LCD panel is plate glass. Do not subject the panel to mechanical shock or to excessive force on its surface.
2. The polarizer attached to the display is easily damaged. Please handle it carefully to avoid scratch or other damages.
3. To avoid contamination on the display surface, do not touch the module surface with bare hands.
4. Keep a space so that the LCD panels do not touch other components.
5. Put cover board such as acrylic board on the surface of LCD panel to protect panel from damages.
6. Transparent electrodes may be disconnected if you use the LCD panel under environmental conditions where the condensation of dew occurs.
7. Do not leave module in direct sunlight to avoid malfunction of the ICs.

9-3 Static Electricity

1. Be sure to ground module before turning on power or operation module.
2. Do not apply voltage which exceeds the absolute maximum rating value.

9-4 Storage

1. Store the module in a dark room where must keep at $+25\pm 10^{\circ}\text{C}$ and 65%RH or less.
2. Do not store the module in surroundings containing organic solvent or corrosive gas.
3. Store the module in an anti-electrostatic container or bag.

9-5 Cleaning

1. Do not wipe the polarizer with dry cloth. It might cause scratch.
2. Only use a soft sloth with IPA to wipe the polarizer, other chemicals might permanent damage to the polarizer.

9-5 Others

1. AMIPRE will provide one year warrantee for all products and three months warrantee for all repairing products.

10. OUTLINE DIMENSION

