

Doc. Number :

Tentative Specification
 Preliminary Specification
 Approval Specification

MODEL NO.: G121I1
SUFFIX: L01

Customer:	
APPROVED BY	SIGNATURE
<u>Name / Title</u>	_____
Note	
_____ Please return 1 copy for your confirmation with your signature and comments.	

核准時間	部門	審核	角色	投票
2011-08-25 21:39:56	APPL 產品管理處	yuhsiang.chang (張喻翔/514-10922)	Director	Accept

CONTENTS

REVISION HISTORY	-----	3
1. GENERAL DESCRIPTION	-----	4
1.1 OVERVIEW		
1.2 GENERAL SPECIFICATIONS		
2. MECHANICAL SPECIFICATIONS	-----	4
3. ABSOLUTE MAXIMUM RATINGS	-----	4
3.1 ABSOLUTE RATINGS OF ENVIRONMENT		
3.2 ELECTRONICAL ABSOLUTE RATINGS		
3.2.1 TFT LCD MODULE		
3.2.2 BACKLIGHT UNIT		
4. ELECTRICAL SPECIFICATION	-----	6
4.1 FUNCTION BLOCK DIAGRAM		
4.2 INTERFACE CONNECTIONS		
4.3 ELECTRICAL CHARACTERISTICS		
4.3.1 LCD ELECTRONICS SPECIFICATION		
4.3.2 BACKLIGHT UNIT		
4.4 LVDS INPUT SIGNAL SPECIFICATIONS		
4.4.1 COLOR DATA INPUT ASSIGNMENT		
4.5 DISPLAY TIMING SPECIFICATIONS		
4.6 POWER ON/OFF SEQUENCE		
5. OPTICAL CHARACTERISTICS	-----	16
5.1 TEST CONDITIONS		
5.2 OPTICAL SPECIFICATIONS		
6. Reliability Test Criteria	-----	19
7. PACKING	-----	20
7.1 PACKING SPECIFICATIONS		
7.2 PACKING METHOD		
7.3 PALLET		
8. CMI MODULE LABEL	-----	22
8.1 MODULE LABEL		
8.2 CARTON LABEL		
9. PRECAUTIONS	-----	23
9.1 ASSEMBLY AND HANDLING PRECAUTIONS		
9.2 STORAGE PRECAUTIONS		
9.3 OPERATION PRECAUTIONS		
9.4 OTHER PRECAUTIONS		
APPENDIX: OUTLINE DIMENSION	-----	24

REVISION HISTORY

Version	Date	Page	Description
2.0	Sep.19, 2010	All	Spec Ver.2.0 was first issued.
2.1	Nov.18,2010	6	Modified 3.2.2 Table
2.1	Nov.18,2010	10	Modified 4.3.2 and Note (3)
2.2	Feb.15,2011	10	Added EN control level and PWM control level spec in 4.3.2
2.3	Aug.10,2011	10	Modified 4.3.2 and Note

1. GENERAL DESCRIPTION

1.1 OVERVIEW

G12111-L01 is a 12.1" TFT Liquid Crystal Display module with LED Backlight unit and 30 pins LVDS interface.

This module supports 1280 x 800 Wide-XGA MVA mode and can display 262,144 colors. The LED converter for Backlight is built in control board.

1.2 GENERAL SPECIFICATIONS

Item	Specification	Unit	Note
Screen Size	12.1" real diagonal		
Driver Element	a-si TFT active matrix	-	-
Pixel Number	1280 x R.G.B. x 800	pixel	-
Pixel Pitch	0.204(H) x 0.204 (V)	mm	-
Pixel Arrangement	RGB vertical stripe	-	-
Display Colors	262K/16.2M	color	-
Transmissive Mode	Normally Black	-	-
Surface Treatment	AG type, 3H hard coating	-	-
Luminance, White	400	Cd/m2	
Power Consumption	Total 10.15 W (Max.) @ cell 1.65 W (Max.), BL 8.5 W (Max.)		

2. MECHANICAL SPECIFICATIONS

Item		Min.	Typ.	Max.	Unit	Note
Module Size	Horizontal (H)	277.5	278	278.5	mm	(1)
	Vertical (V)	183.5	184	184.5	mm	
	Thickness (T)	7.66	8.16	8.66	mm	
Bezel Area	Horizontal	264.6	265.10	265.6	mm	
	Vertical	162.7	163.2	163.7	mm	
Active Area	Horizontal	-	261.12	-	mm	
	Vertical	-	163.2	-	mm	
Weight		-	455	-	g	

Note (1) Please refer to the attached drawings for more information of front and back outline dimensions.

3. ABSOLUTE MAXIMUM RATINGS

3.1 ABSOLUTE RATINGS OF ENVIRONMENT

Item	Symbol	Value		Unit	Note
		Min.	Max.		
Storage Temperature	TST	-20	80	°C	(1)
Operating Ambient Temperature	TOP	-10	70	°C	(1), (2)

Note (1)

(a) 90 %RH Max. (Ta <= 40 °C).

(b) Wet-bulb temperature should be 39 °C Max. (Ta > 40 °C).

(c) No condensation.

Note (2) The temperature of panel surface should be -10 °C min. and 70 °C max.

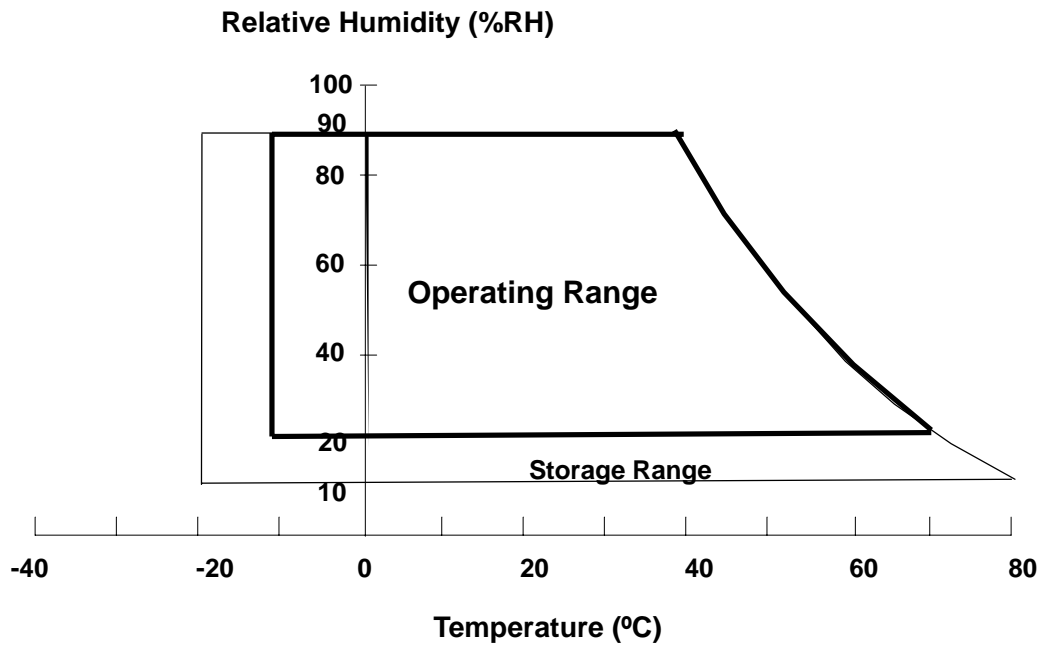

Note (3) 1 time for ± X, ± Y, ± Z. for Condition (25G / 6ms) is half Sine Wave,.

Note (4) 5- 9Hz: 3,5mm amplitude 9- 500Hz: 1g- each 10 cycles / axis (X,Y,Z); 1 octave / min.

Note (5) At testing Vibration and Shock, the fixture in holding the module has to be hard and rigid enough so that the module would not be twisted or bent by the fixture.

The fixing condition is shown as below:

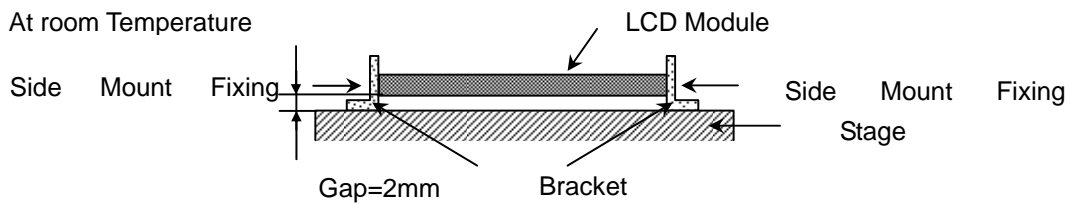

3.2 ELECTRICAL ABSOLUTE RATINGS

3.2.1 TFT LCD MODULE

Item	Symbol	Value		Unit	Note
		Min.	Max.		
Power Supply Voltage	V _{CCS}	-0.3	+4.0	V	(1)
Logic Input Voltage	V _{IN}	-0.3	V _{CC} +0.3	V	

3.2.2 BACKLIGHT UNIT

Item	Value			Unit	Note
	Min	Typ.	Max.		
LED Converter Input voltage	10.8	12.0	15.0	V_{DC}	(1), (2)
LED Converter Input Current	-	0.7	-	mA_{DC}	

Note (1) Permanent damage to the device may occur if maximum values are exceeded. Function operation should be restricted to the conditions described under Normal Operating Conditions.

Note (2) Specified values are for LED (Refer to Section 3.2 for further information).

4. ELECTRICAL SPECIFICATIONS

4.1 FUNCTION BLOCK DIAGRAM

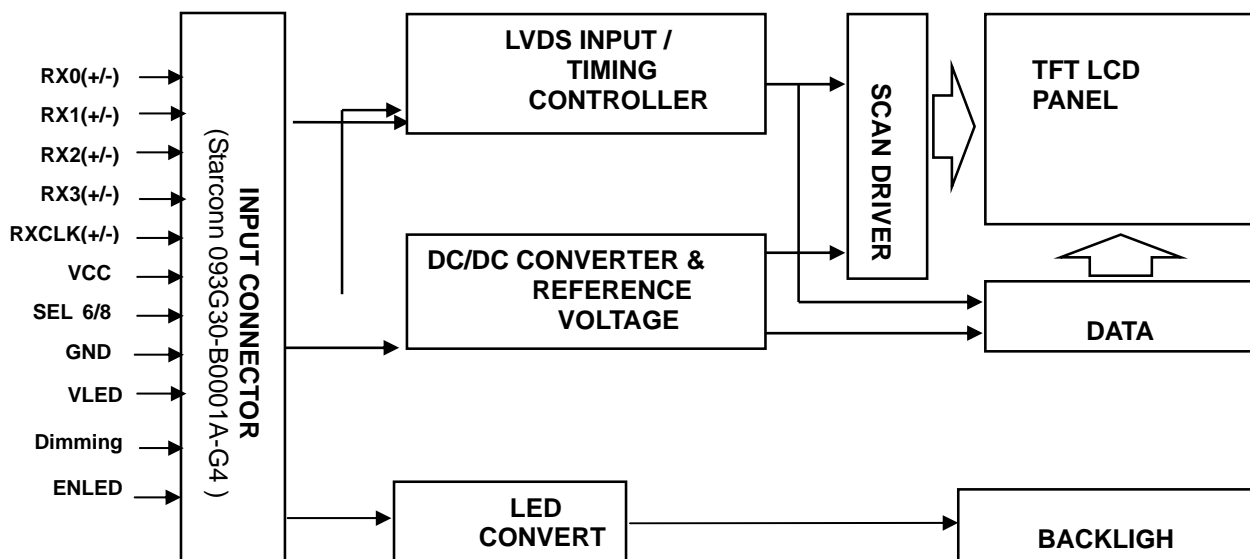

4.2. INTERFACE CONNECTIONS

PIN ASSIGNMENT

Pin No.	Symbol	Description	Note
1	12V	LED power	-
2	12V	LED power	-
3	12V	LED power	-
4	12V	LED power	-
5	ENLED	Enable pin	-
6	Dimming	Backlight Adjust	-
7	GND	Ground	-
8	GND	Ground	-
9	VCC	Power supply: +3.3V	
10	VCC	Power supply: +3.3V	-
11	GND	Ground	-
12	GND	Ground	-
13	RX0-	Negative transmission data of pixel 0	-
14	RX0+	Positive transmission data of pixel 0	-
15	GND	Ground	-
16	RX1-	Negative transmission data of pixel 1	-
17	RX1+	Positive transmission data of pixel 1	-
18	GND	Ground	-
19	RX2-	Negative transmission data of pixel 2	-
20	RX2+	Positive transmission data of pixel 2	-
21	GND	Ground	-
22	RXCLK-	Negative of clock	-
23	RXCLK+	Positive of clock	-
24	GND	Ground	-
25	RX3-	Negative transmission data of pixel 3	-
26	RX3+	Positive transmission data of pixel 3	-
27	GND	Ground	-
28	SEL6/8	LVDS 6/8 bit select function control,	(2)
		Low or NC → 6 bit Input Mode	
		High → 8bit Input Mode	
29	GND	Ground	-
30	GND	Ground	-

Note (1) Connector Part No.: Starconn 093G30-B0001A-G4

Note (2) "Low" stands for 0V. "High" stands for 3.3V

4.3 ELECTRICAL CHARACTERISTICS

4.3.1 LCD ELETRONICS SPECIFICATION

Parameter	Symbol	Value			Unit	Note	
		Min.	Typ	Max.			
Power Supply Voltage	V _{CC}	3.0	3.3	3.6	V	-	
Permissive Ripple Voltage	V _{RP}	-	50	-	mV	-	
Rush Current	I _{RUSH}	-	-	1.5	A	(2)	
Initial Stage Current	I _{IS}	-	-	1.0	A	(2)	
Power Supply Current	White	-	450	500	550	mA	(3)a
	Black	-	350	385	420	mA	(3)b
LVDS Differential Input High Threshold	V _{TH(LVDS)}	-	-	+100	mV	(5), V _{CM} =1.2V	
LVDS Differential Input Low Threshold	V _{TL(LVDS)}	-100	-	-	mV	(5), V _{CM} =1.2V	
LVDS Common Mode Voltage	V _{CM}	1.125	-	1.375	V	(5)	
LVDS Differential Input Voltage	V _{ID}	100	-	600	mV	(5)	
Terminating Resistor	R _T	-	100	-	Ohm		
Power per EBL WG	P _{EBL}	-	2.68	-	W	(4)	

Note (1) The assembly should be always operated within above ranges.

Note (2) Measurement Conditions:

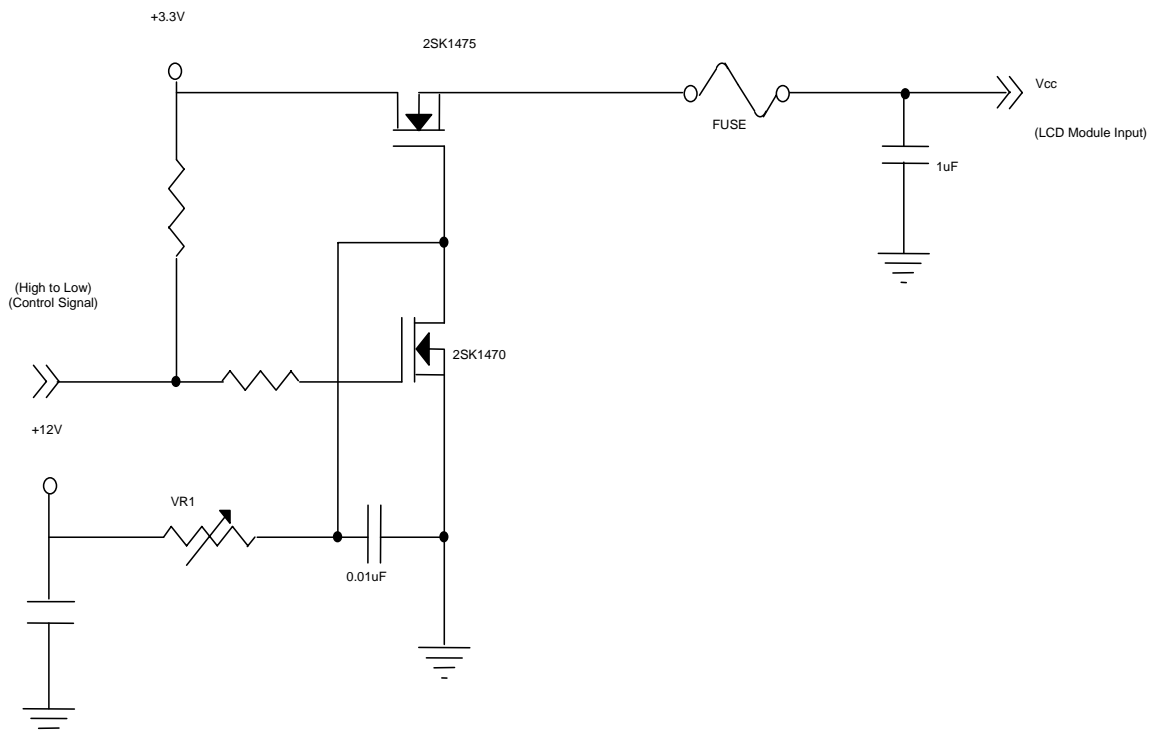

VCC rising time is 470us

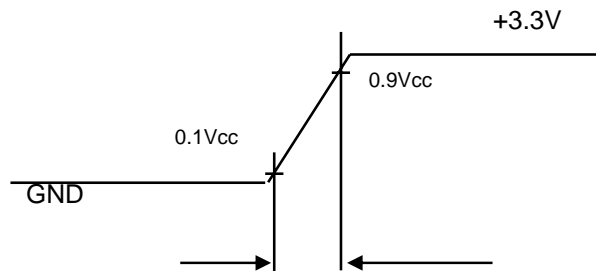

Note (3)The specified power supply current is under the conditions at $V_{cc} = 3.3\text{ V}$, $T_a = 25 \pm 2\text{ }^\circ\text{C}$, $f_v = 60\text{ Hz}$,
 whereas a power dissipation check pattern below is

a. White Pattern

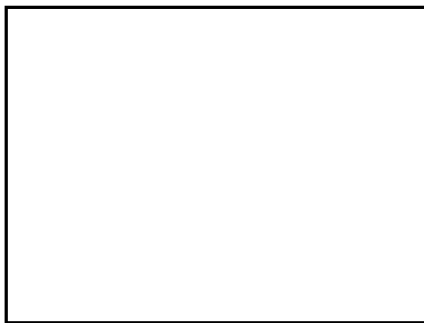

Active Area

b. Black Pattern

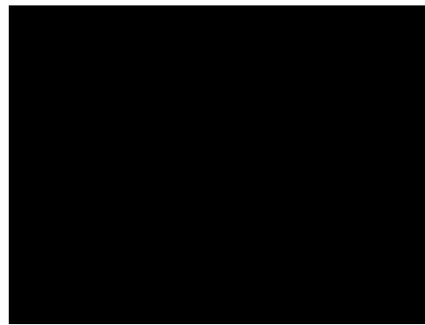

Active Area

c. Vertical Stripe Pattern

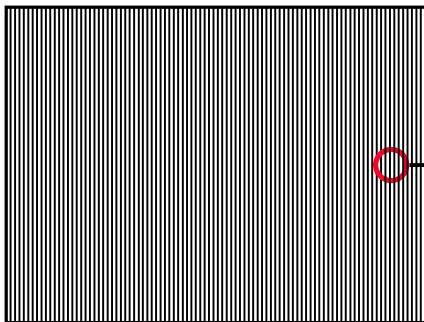

Active Area

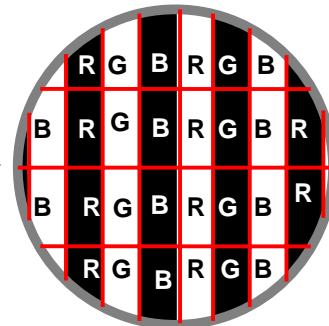

4.3.2 BACKLIGHT UNIT

Parameter	Symbol	Value			Unit	Note
		Min.	Typ.	Max.		
(LED Converter input voltage)	V_i	10.8	12	15.0	V_{DC}	(Duty 100%)
(LED light bar input current)	I_i	0.8	0.7	0.6	A_{DC}	(Duty 100%)
LED Lightbar Voltage	V_f	-	35.2	-	V_{DC}	$I_f = 80 \text{ mA/EA}$
LED Current	I_f	-	80	-	mA	Per EA
Power Consumption	P_L	-	8.5	-	W	(3)
EN Control Level	Backlight on	2.0	3.3	5.0	V	
	Backlight off	0	---	0.8	V	
PWM Control Level	PWM High Level	2.0	---	5.0	V	
	PWM Low Level	0	---	0.15	V	
PWM Control Frequency	f_{PWM}	190	200	20k	Hz	(2)
PWM Control Duty Ratio		2		100	%	(2)
LED Life Time	L_{BL}	50000	-	-	Hrs	(3)

Note (1) LED current is measured by utilizing a high frequency current meter as shown below:

Note (2) :At 190 ~1KHz PWM control frequency, duty ratio range is restricted from 2% to 100%.

1K ~20KHz PWM control frequency , minimum duty on-time 20 us.

Note (3) The lifetime of LED is defined as the time when it continues to operate under the conditions at

$T_a = 25 \pm 2$ and $I_{LED} = 80 \text{ mA}_{DC}$ (LED forward current) until the brightness becomes 50% of its original value. Operating LED under high temperature environment will reduce life time and lead to color shift.

Note (4) $P_L = I_o \times V_o$

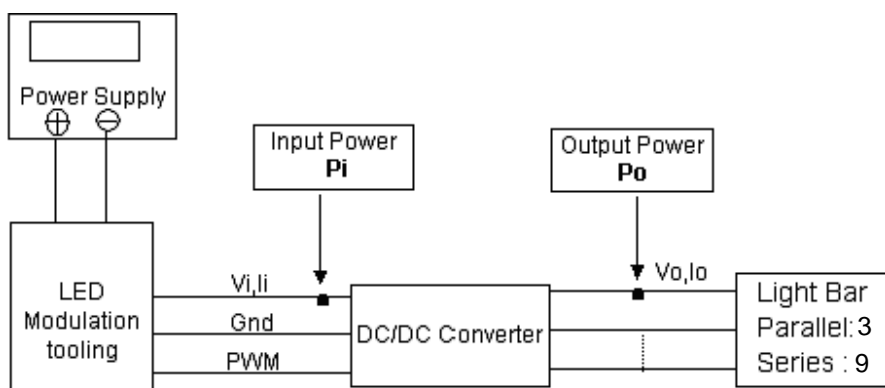

4.4 LVDS INPUT SIGNAL SPECIFICATIONS**4.4.1 COLOR DATA INPUT ASSIGNMENT**

The brightness of each primary color (red, green and blue) is based on the 6-bit gray scale data input for the color. The higher the binary input, the brighter the color. The table below provides the assignment of color.

Color		Data Signal																	
		Red						Green						Blue					
		R5	R4	R3	R2	R1	R0	G5	G4	G3	G2	G1	G0	B5	B4	B3	B2	B1	B0
Basic Colors	Black	0	0	0	0	0	0	0	0	0	0	0	0	0	0	0	0	0	0
	Red	1	1	1	1	1	1	0	0	0	0	0	0	0	0	0	0	0	0
	Green	0	0	0	0	0	0	1	1	1	1	1	1	0	0	0	0	0	0
	Blue	0	0	0	0	0	0	0	0	0	0	0	0	1	1	1	1	1	1
	Cyan	0	0	0	0	0	0	1	1	1	1	1	1	1	1	1	1	1	1
	Magenta	1	1	1	1	1	1	0	0	0	0	0	0	1	1	1	1	1	1
	Yellow	1	1	1	1	1	1	1	1	1	1	1	1	0	0	0	0	0	0
	White	1	1	1	1	1	1	1	1	1	1	1	1	1	1	1	1	1	1
Gray Scale Of Red	Red(0)/Dark	0	0	0	0	0	0	0	0	0	0	0	0	0	0	0	0	0	0
	Red(1)	0	0	0	0	0	1	0	0	0	0	0	0	0	0	0	0	0	0
	Red(2)	0	0	0	0	1	0	0	0	0	0	0	0	0	0	0	0	0	0
	:	:	:	:	:	:	:	:	:	:	:	:	:	:	:	:	:	:	:
	:	:	:	:	:	:	:	:	:	:	:	:	:	:	:	:	:	:	:
	Red(61)	1	1	1	1	0	1	0	0	0	0	0	0	0	0	0	0	0	0
	Red(62)	1	1	1	1	1	0	0	0	0	0	0	0	0	0	0	0	0	0
	Red(63)	1	1	1	1	1	1	0	0	0	0	0	0	0	0	0	0	0	0
Gray Scale Of Green	Green(0)/Dark	0	0	0	0	0	0	0	0	0	0	0	0	0	0	0	0	0	0
	Green(1)	0	0	0	0	0	0	0	0	0	0	0	1	0	0	0	0	0	0
	Green(2)	0	0	0	0	0	0	0	0	0	0	1	0	0	0	0	0	0	0
	:	:	:	:	:	:	:	:	:	:	:	:	:	:	:	:	:	:	:
	:	:	:	:	:	:	:	:	:	:	:	:	:	:	:	:	:	:	:
	Green(61)	0	0	0	0	0	0	1	1	1	1	0	1	0	0	0	0	0	0
	Green(62)	0	0	0	0	0	0	1	1	1	1	1	0	0	0	0	0	0	0
	Green(63)	0	0	0	0	0	0	1	1	1	1	1	1	0	0	0	0	0	0
Gray Scale Of Blue	Blue(0)/Dark	0	0	0	0	0	0	0	0	0	0	0	0	0	0	0	0	0	0
	Blue(1)	0	0	0	0	0	0	0	0	0	0	0	0	0	0	0	0	0	1
	Blue(2)	0	0	0	0	0	0	0	0	0	0	0	0	0	0	0	0	1	0
	:	:	:	:	:	:	:	:	:	:	:	:	:	:	:	:	:	:	:
	:	:	:	:	:	:	:	:	:	:	:	:	:	:	:	:	:	:	:
	Blue(61)	0	0	0	0	0	0	0	0	0	0	0	0	1	1	1	1	0	1
	Blue(62)	0	0	0	0	0	0	0	0	0	0	0	0	1	1	1	1	1	0
	Blue(63)	0	0	0	0	0	0	0	0	0	0	0	0	1	1	1	1	1	1

Note (1) 0: Low Level Voltage, 1: High Level Voltage

4.5 DISPLAY TIMING SPECIFICATIONS

The input signal timing specifications are shown as the following table and timing diagram.

Signal	Item	Symbol	Min.	Typ.	Max.	Unit	Note
DCLK	Frequency	1/Tc	67.45	71	74.55	MHz	-
DE	Vertical Total Time	TV	810	823	1000	TH	-
	Vertical Addressing Time	TVD	800	800	800	TH	-
	Horizontal Total Time	TH	1360	1440	1600	Tc	-
	Horizontal Addressing Time	THD	1280	1280	1280	Tc	-

Note: Because this module is operated by DE only mode, Hsync and Vsync input signals are ignored.

INPUT SIGNAL TIMING DIAGRAM

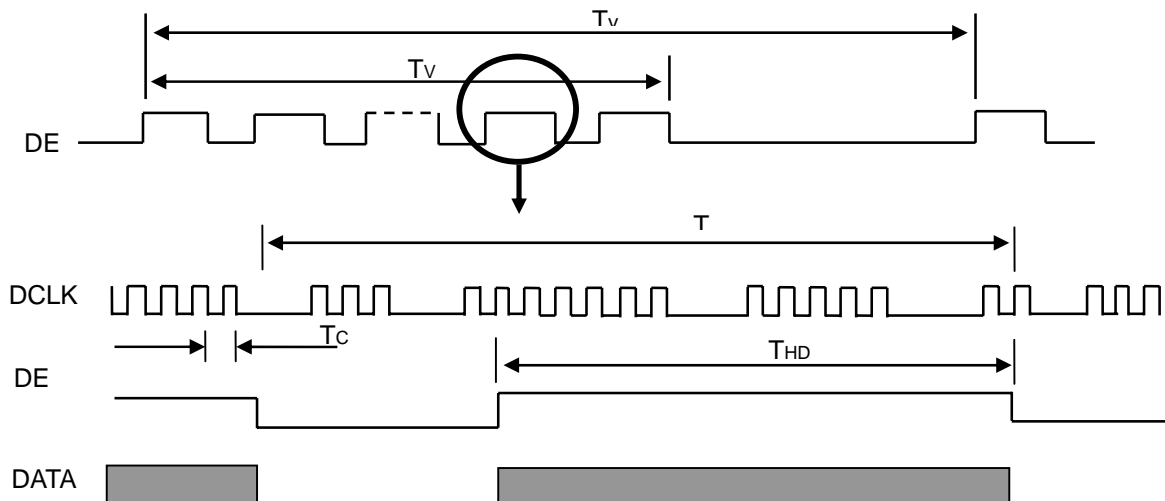

4.6 POWER ON/OFF SEQUENCE

To prevent a latch-up or DC operation of LCD assembly, the power on/off sequence should be as the diagram below.

Power ON/OFF sequence

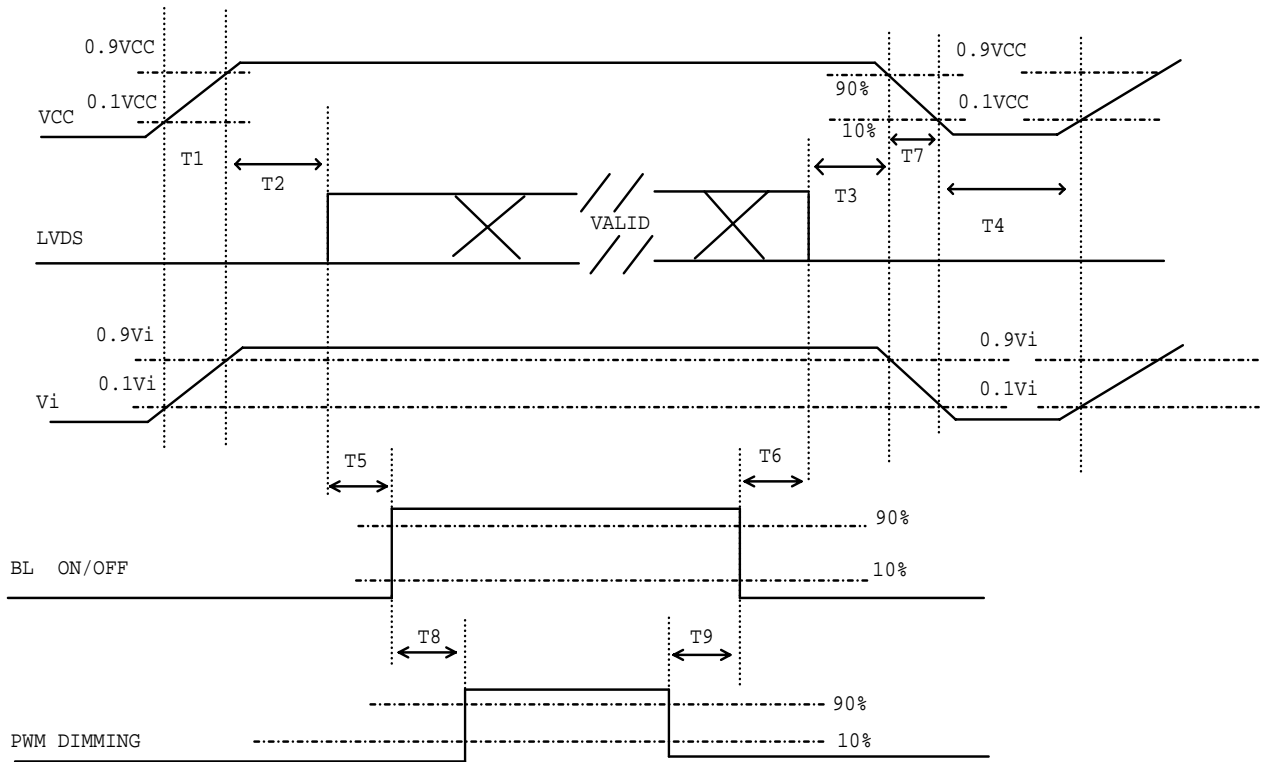

Note (1) Please avoid floating state of interface signal at invalid period.

Note (2) When the interface signal is invalid, be sure to pull down the power supply of LCD VCC to 0 V.

Note (3) The Backlight converter power must be turned on after the power supply for the logic and the interface signal is valid. The Backlight converter power must be turned off before the power supply for the logic and the interface signal is invalid.

Parameter	Value			Units
	Min	Typ	Max	
T1	0.5	---	10	ms
T2	0	---	50	ms
T3	0	---	50	ms
T4	500	---	---	ms
T5	200	---	---	ms
T6	20	---	---	ms
T7	5	---	300	ms
T8	10	---	---	ms
T9	10	---	---	ms

The Input Data Format

SEL 6/8="Low" or "NC" for 6 Bits LVDS

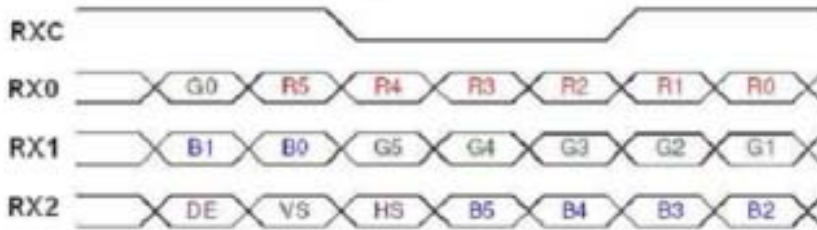

SEL 6/8="High" for 8 Bits LVDS



Note (1) R/G/B data 7: MSB, R/G/B data 0: LSB

Note (2) Please follow PSWG

Signal Name	Description	Remark
R7	Red Data 7 (MSB)	Red-pixel Data Each red pixel's brightness data consists of these 8 bits pixel data.
R6	Red Data 6	
R5	Red Data 5	
R4	Red Data 4	
R3	Red Data 3	
R2	Red Data 2	
R1	Red Data 1	
R0	Red Data 0 (LSB)	
G7	Green Data 7 (MSB)	Green-pixel Data Each green pixel's brightness data consists of these 8 bits pixel data.
G6	GreenData 6	
G5	GreenData 5	
G4	GreenData 4	
G3	GreenData 3	
G2	GreenData 2	
G1	GreenData 1	
G0	GreenData 0 (LSB)	
B7	Blue Data 7 (MSB)	Blue-pixel Data Each blue pixel's brightness data consists of these 8 bits pixel data.
B6	Blue Data 6	
B5	Blue Data 5	
B4	Blue Data 4	
B3	Blue Data 3	
B2	Blue Data 2	
B1	Blue Data 1	
B0	Blue Data 0 (LSB)	
RXCLKIN+	LVDS Clock Input	
RXCLKIN-		
DE	Display Enable	
VS	Vertical Sync	
HS	Horizontal Sync	

5. OPTICAL CHARACTERISTICS

5.1 TEST CONDITIONS

Item	Symbol	Value	Unit
Ambient Temperature	Ta	25±2	°C
Ambient Humidity	Ha	50±10	%RH
Supply Voltage	V _{CC}	3.3	V
Input Signal	According to typical value in "3. ELECTRICAL CHARACTERISTICS"		
LED Light Bar Input Current	I _L	120	mA

The measurement methods of optical characteristics are shown in Section 5.2. The following items should be measured under the test conditions described in Section 5.1 and stable environment shown in Note (5).

5.2 OPTICAL SPECIFICATIONS

The relative measurement methods of optical characteristics are shown in 5.2. The following items should be measured under the test conditions described in 5.1 and stable environment shown in Note (5).

Item	Symbol	Condition	Min.	Typ.	Max.	Unit	Note	
Contrast Ratio	CR	$\theta_x=0^\circ, \theta_y=0^\circ$ Viewing Normal Angle	800	1000	-	-	(2), (5)	
Response Time	T _R		-	15	20	ms	(3)	
	T _F		-	10	15	ms		
Luminance of White (5P)	L _{AVE}		300	400	-	cd/m ²	(4), (5)	
White Variation	δW		-	1.25	1.4	-	(5), (6)	
Color Chromaticity	Red		R _x	Typ. - 0.05	0.565	Typ. + 0.05	-	(1), (5)
			R _y		0.351		-	
	Green		G _x		0.357		-	
			G _y		0.590		-	
	Blue		B _x		0.155		-	
		B _y	0.131		-			
	White	W _x	0.313		-			
		W _y	0.329		-			
Viewing Angle	Horizontal	θ_{x+}	CR≥10	80	88	-	Deg .	
		θ_{x-}		80	88	-		
	Vertical	θ_{y+}		80	88	-		
		θ_{y-}		80	88	-		

Note (1) Definition of Viewing Angle (θ_x, θ_y):

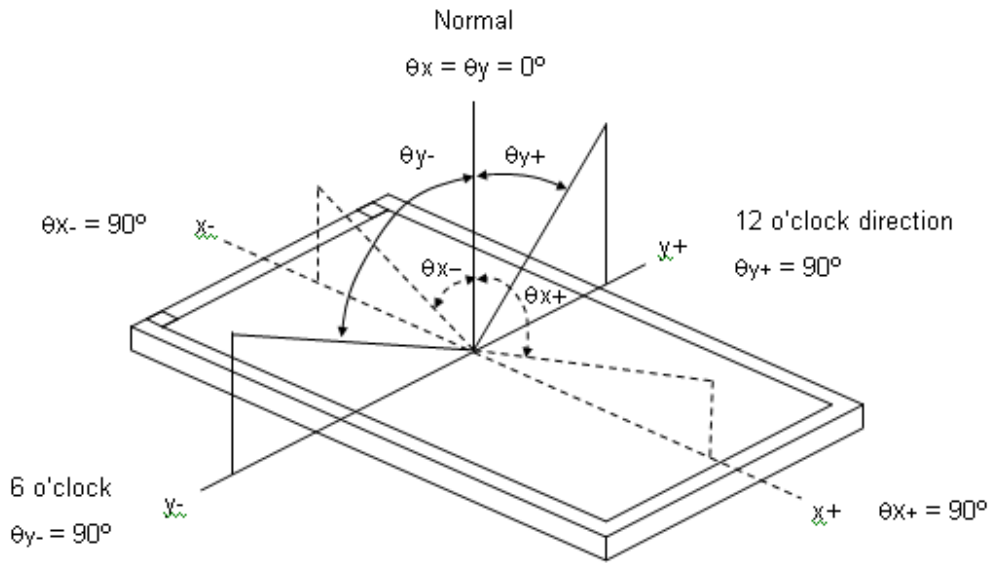

Note (2) Definition of Contrast Ratio (CR):

The contrast ratio can be calculated by the following expression.

$$\text{Contrast Ratio (CR)} = L_{255} / L_0$$

L255: Luminance of gray level 255

L 0: Luminance of gray level 0

$$\text{CR} = \text{CR} (5)$$

CR (X) is corresponding to the Contrast Ratio of the point X at Figure in Note (6).

Note (3) Definition of Response Time (T_R, T_F):

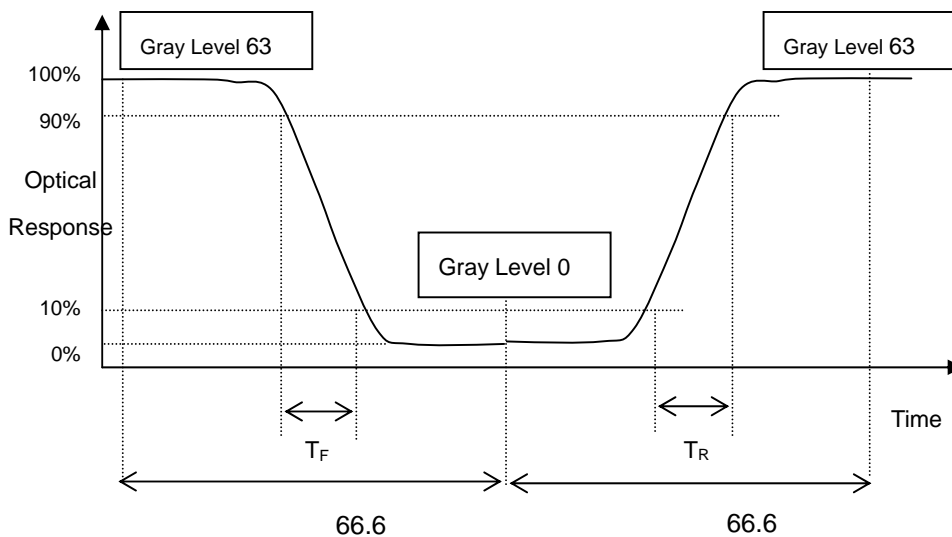

Note (4) Definition of Average Luminance of White (L_{AVE}):

Measure the luminance of gray level 63 at 5 points

$$L_{AVE} = [L(1) + L(2) + L(3) + L(4) + L(5)] / 5$$

L(x) is corresponding to the luminance of the point X at Figure in Note (6).

Note (5) Measurement Setup:

The LCD module should be stabilized at given temperature for 15 minutes to avoid abrupt temperature change during measuring. In order to stabilize the luminance, the measurement should be executed after lighting Backlight for 15 minutes in a windless room.

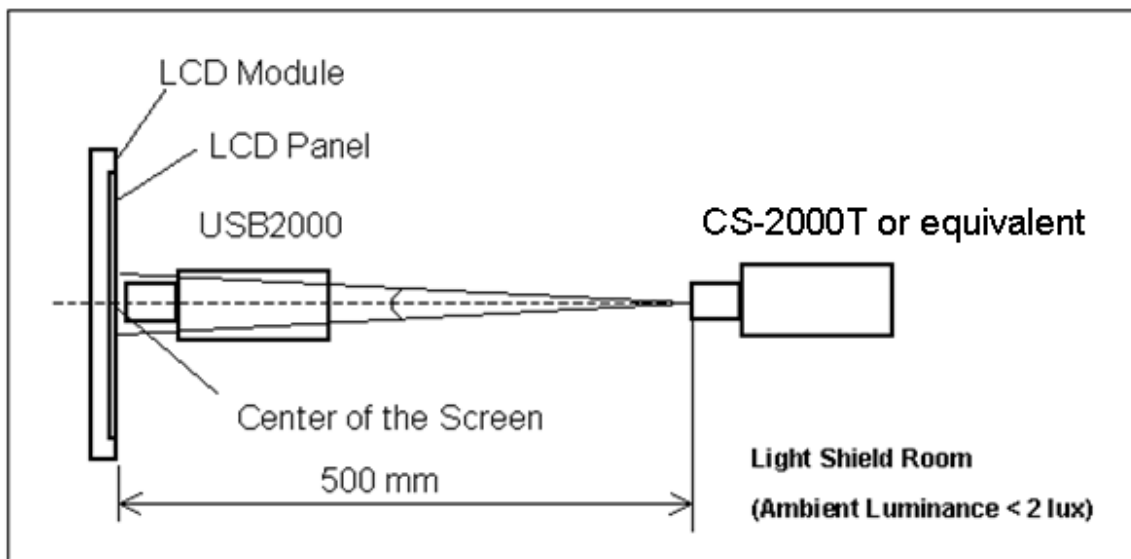

Note (6) Definition of White Variation (δW):

Measure the luminance of gray level 63 at 5 points

$$\delta W = \text{Maximum} [L(1), L(2), L(3), L(4), L(5)] / \text{Minimum} [L(1), L(2), L(3), L(4), L(5)]$$

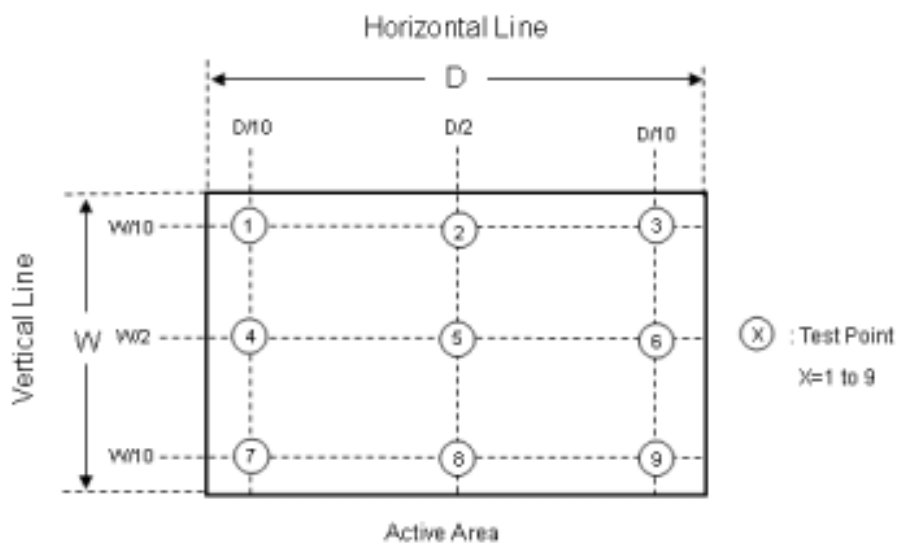

6. Reliability Test Criteria

Test Item	Test Condition	Note
High Temperature Storage Test	80°C, 240 hours	(1) (2)
Low Temperature Storage Test	-20°C, 240 hours	
Thermal Shock Storage Test	-20°C, 0.5hour 80 , 0.5hour; 100cycles, 1hour/cycle	
High Temperature Operation Test	70°C, 240 hours	
Low Temperature Operation Test	-10°C, 240 hours	
High Temperature & High Humidity Operation Test	60°C, 90%RH, 240hours	
Shock (Non-Operating)	25G, 6ms, half sine wave, 1 time for $\pm X$, $\pm Y$, $\pm Z$.	(3)
Vibration (Non-Operating)	5- 9Hz: 3,5mm amplitude 9- 500Hz: 1g- each 10 cycles / axis (X,Y,Z); 1 octave / min	(3)

Note (1) There should be no condensation on the surface of panel during test.

Note (2) Temperature of panel display surface area should be 80 °C Max

Note (3)At testing Vibration and Shock, the fixture in holding the module has to be hard and rigid enough so that the module would not be twisted or bent by the fixture.

7. PACKING

7.1 PACKING SPECIFICATIONS

- (1) 20pcs LCD modules / 1 Box
- (2) Box dimensions: 465 (L) X 362 (W) X 314 (H) mm
- (3) Weight: approximately 16Kg (20modules per box)

7.2 PACKING METHOD

(1) Carton Packing should have no failure in the following reliability test items.

Test Item	Test Conditions	Note
Vibration	ISTA STANDARD Random, Frequency Range: 2 – 200 Hz Top & Bottom: 30 minutes (+Z), 10 min (-Z), Right & Left: 10 minutes (X) Back & Forth 10 minutes (Y)	Non Operation
Dropping Test	1 Angle, 3 Edge, 6 Face, 61 cm	Non Operation

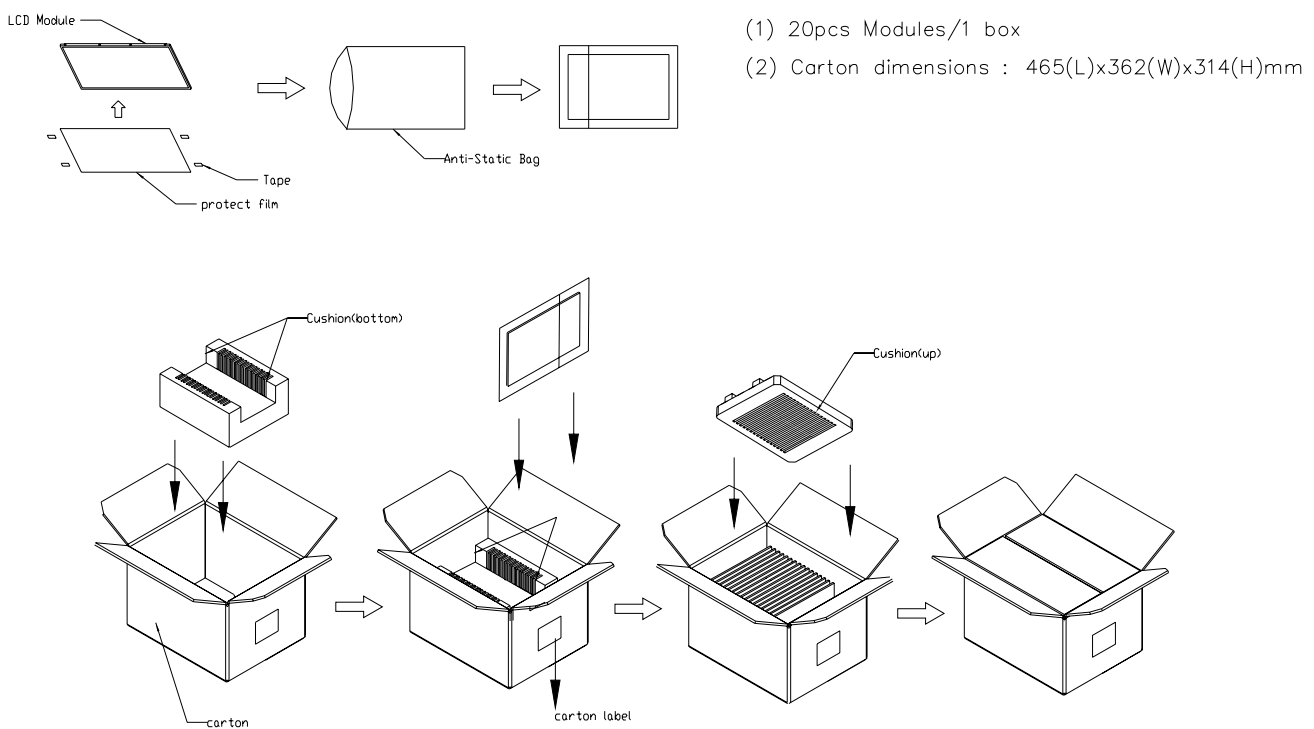

Figure. 6-1 Packing method

7.3 PALLET

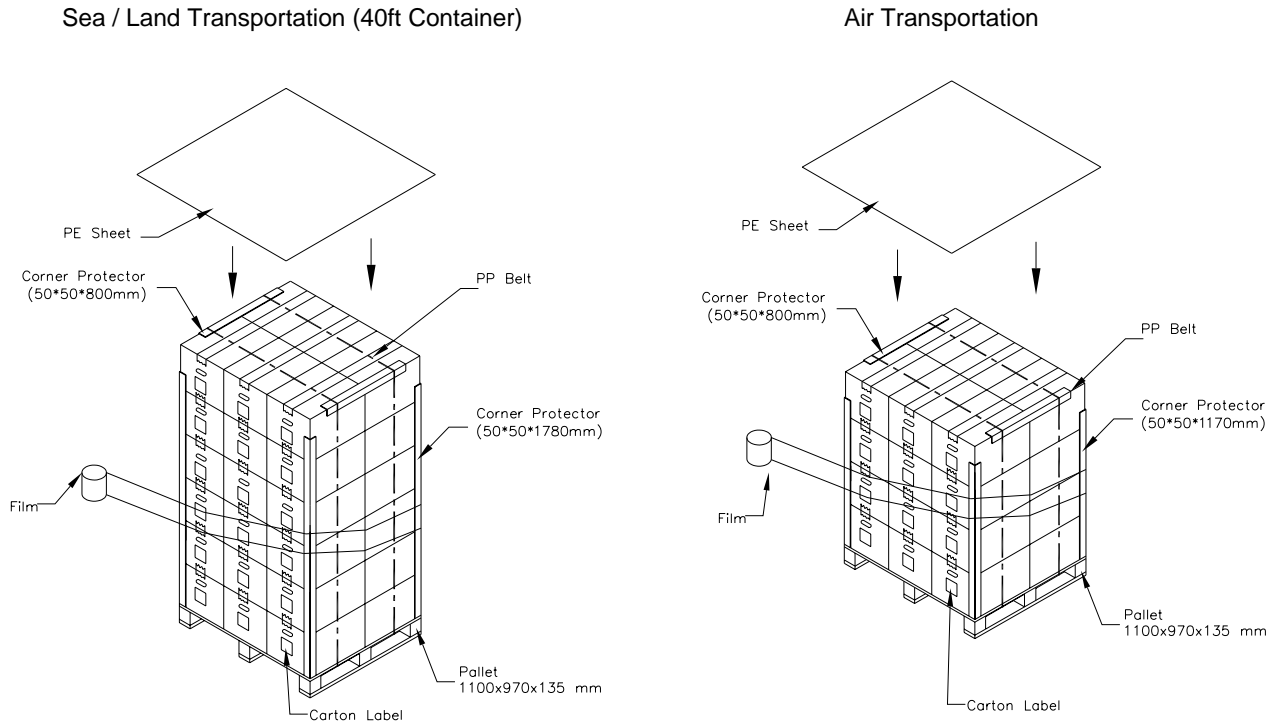

Figure. 6-2 Packing method

8. CMI MODULE LABEL

8.1 MODULE LABEL

The barcode nameplate is pasted on each module as illustration, and its definitions are as following explanation.



(a) Model Name: G12111-L01

(b) Revision: Rev. XX, for example: A0, A1... B1, B2... or C1, C2...etc.

(c) CMI barcode definition:

Serial ID: XX-XX-X-XX-YMD-L-NNNN

Code	Meaning	Description
XX	CMI internal use	-
XX	Revision	Cover all the change
X	CMI internal use	-
XX	CMI internal use	-
YMD	Year, month, day	Year: 0~9, 2001=1, 2002=2, 2003=3...2010=0, 2011=1, 2012=2... Month: 1~12=1, 2, 3, ~, 9, A, B, C Day: 1~31=1, 2, 3, ~, 9, A, B, C, ~, W, X, Y, exclude I, O, and U.
L	Product line #	Line 1=1, Line 2=2, Line 3=3, ...
NNNN	Serial number	Manufacturing sequence of product

8.2 CARTON LABEL

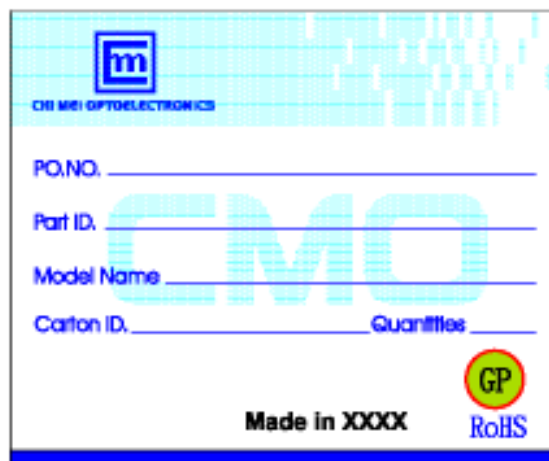

(a) P/N: Internal control

(b) Model Name: G12111-L01

(c) Production year and month: shown at left down corner

(d) Production location: Made In XXXX. XXXX stands for production location.

9. PRECAUTIONS**9.1 ASSEMBLY AND HANDLING PRECAUTIONS**

- (1) The module should be assembled into the system firmly by using every mounting hole. Be careful not to twist or bend the module.
- (2) While assembling or installing modules, it can only be in the clean area. The dust and oil may cause electrical short or damage the polarizer.
- (3) Use fingerstalls or soft gloves in order to keep display clean during the incoming inspection and assembly process.
- (4) Do not press or scratch the surface harder than a HB pencil lead on the panel because the polarizer is very soft and easily scratched.
- (5) If the surface of the polarizer is dirty, please clean it by some absorbent cotton or soft cloth. Do not use Ketone type materials (ex. Acetone), Ethyl alcohol, Toluene, Ethyl acid or Methyl chloride. It might permanently damage the polarizer due to chemical reaction.
- (6) Wipe off water droplets or oil immediately. Staining and discoloration may occur if they left on panel for a long time.
- (7) If the liquid crystal material leaks from the panel, it should be kept away from the eyes or mouth. In case of contacting with hands, legs or clothes, it must be washed away thoroughly with soap.
- (8) Protect the module from static electricity, it may cause damage to the C-MOS Gate Array IC.
- (9) Do not disassemble the module.
- (10) Do not pull or fold the lamp wire.
- (11) Pins of I/F connector should not be touched directly with bare hands.

9.2 STORAGE PRECAUTIONS

- (1) High temperature or humidity may reduce the performance of module. Please store LCD module within the specified storage conditions.
- (2) It is dangerous that moisture come into or contacted the LCD module, because the moisture may damage LCD module when it is operating.
- (3) It may reduce the display quality if the ambient temperature is lower than 10 °C. For example, the response time will become slowly, and the starting voltage of lamp will be higher than the room temperature.

8.3 OPERATION PRECAUTIONS

- (1) Do not pull the I/F connector in or out while the module is operating.
- (2) Always follow the correct power on/off sequence when LCD module is connecting and operating. This can prevent the CMOS LSI chips from damage during latch-up.
- (3) The startup voltage of Backlight is approximately 1000 Volts. It may cause electrical shock while assembling with converter. Do not disassemble the module or insert anything into the Backlight unit.

8.4 OTHER PRECAUTIONS

- (1) When fixed patterns are displayed for a long time, remnant image is likely to occur.

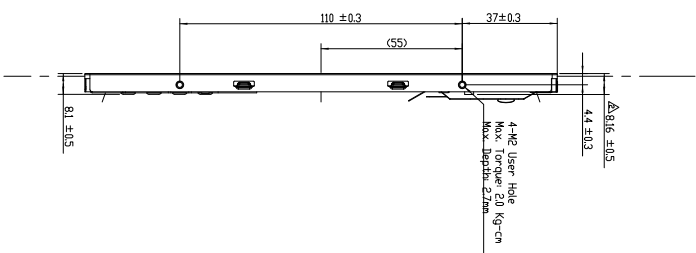
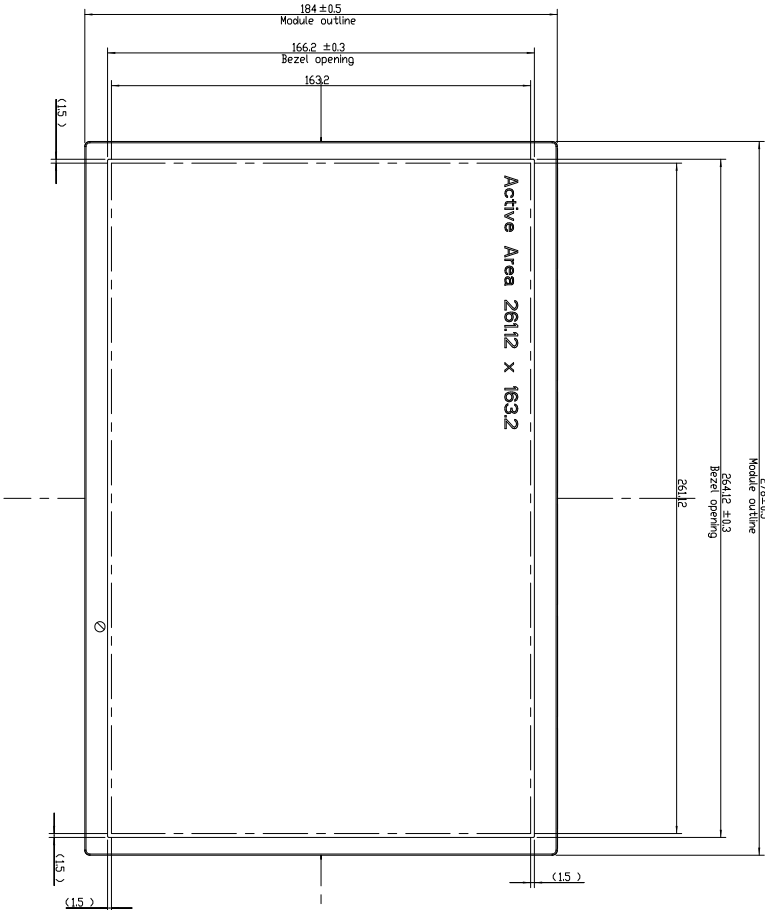
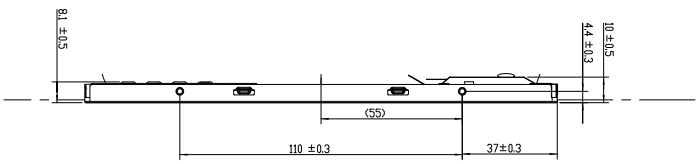

NOTES
 1. OUTLINE TOLERANCE ±0.5mm.
 2. * MARKS THE DESIGN CRITICAL DIMENSION.
 3. * MARKS THE MANUFACTURE CRITICAL DIMENSION.
 4. MAX. SREW LENGTH: 5.7mm.
 5. MAX. SREW TORQUE: 1kg-cm.

Mark	Description	Date	By	Checked By	Approved By	ECN No.	Remark
1							
2	Modify Thickness Dimension	05-Jul-2010	Eason, Sang	SY, F		EP004984	
3							
4							

TITLE: M350 MODULE (G07H-01)		DRAWING NO.: G07H012	
DESIGNED BY: SY, F		CHECKED BY: G07H012	
DRAWN BY: Eason, Sang		DATE: 05-Jul-2010	
MATERIAL: 170		SCALE: 1:1	
SHEET: 1 / 2		TOTAL SHEETS: 2	
		ALL RIGHTS RESERVED. COPY PROHIBITED.	

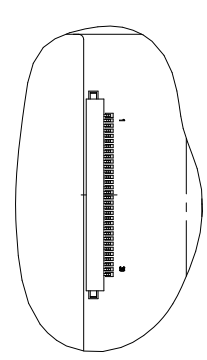
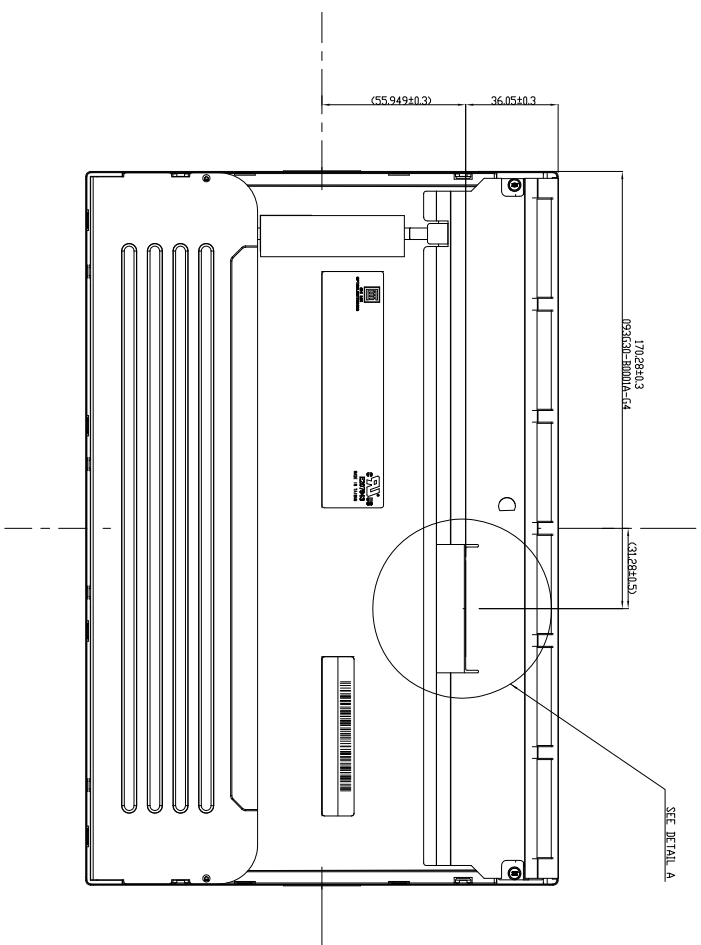

DETAIL A
SCALE 2x

NOTES:
 1. TOLERANCE 405µm
 2. DIMENSIONS MARKS THE DESIGN CRITICAL DIMENSION.
 3. DIMENSIONS MARKS THE PROCESS CRITICAL DIMENSION.
 4. MAX. SURF. FINISH: Ra=0.27µm
 5. MAX. SURF. FINISH: Ra=0.10µm

Mark	Description	Date	Changed By/Approved By	ECN No.	Remark
1	Modify Thickness Dimension	05-Jul-2010	Eason_Siong SY_F	E0004984	--

TITLE: MESH MODULE COVER-06		DRAWING No. G0604012		REV: 02	
Approved SY_F		Drawing No. G0604012		REV: 02	
Checked SY_F		Part No. G0604012		REV: 02	
Designer Eason_Siong		Material 170		Sheet 2 / 2	
Date 05-Jul-2010		Scale 1:1		A1	
CHI MEI		CHI MEI		CHI MEI	
SPECIALTY SERVICES CORP.		SPECIALTY SERVICES CORP.		SPECIALTY SERVICES CORP.	
ALL RIGHTS RESERVED. STRICTLY CONFIDENTIAL		ALL RIGHTS RESERVED. STRICTLY CONFIDENTIAL		ALL RIGHTS RESERVED. STRICTLY CONFIDENTIAL	