

KOE

JDI Group

Kaohsiung Opto-Electronics Inc.

FOR MESSRS : _____

DATE : May 1st, 2012

CUSTOMER'S ACCEPTANCE SPECIFICATIONS

TX14D16VM1CBC

Contents

No.	ITEM	SHEET No.	PAGE
1	COVER	7B64PS 2701-TX14D16VM1CBC-3	1-1/1
2	RECORD OF REVISION	7B64PS 2702-TX14D16VM1CBC-3	2-1/1
3	GENERAL DATA	7B64PS 2703-TX14D16VM1CBC-3	3-1/1
4	ABSOLUTE MAXIMUM RATINGS	7B64PS 2704-TX14D16VM1CBC-3	4-1/1
5	ELECTRICAL CHARACTERISTICS	7B64PS 2705-TX14D16VM1CBC-3	5-1/1
6	OPTICAL CHARACTERISTICS	7B64PS 2706-TX14D16VM1CBC-3	6-1/2~2/2
7	BLOCK DIAGRAM	7B64PS 2707-TX14D16VM1CBC-3	7-1/1
8	RELIABILITY TESTS	7B64PS 2708-TX14D16VM1CBC-3	8-1/1
9	LCD INTERFACE	7B64PS 2709-TX14D16VM1CBC-3	9-1/5~5/5
10	OUTLINE DIMENSIONS	7B64PS 2710-TX14D16VM1CBC-3	10-1/1
11	APPEARANCE STANDARD	7B64PS 2711-TX14D16VM1CBC-3	11-1/3~3/3
12	PRECAUTIONS	7B64PS 2712-TX14D16VM1CBC-3	12-1/2~2/2
13	DESIGNATION OF LOT MARK	7B64PS 2713-TX14D16VM1CBC-3	13-1/1

ACCEPTED BY: _____

PROPOSED BY: 

2. RECORD OF REVISION

DATE	SHEET No.	SUMMARY																						
Nov.25,'11	7B64PS 2706- TX14D16VM1CBC-2 PAGE 6-1/2	6. OPTICAL CHARACTERISTICS Revised: <table border="1" style="width: 100%; border-collapse: collapse; margin-bottom: 10px;"> <thead> <tr> <th style="width: 30%;">Item</th> <th style="width: 15%;">Symbol</th> <th style="width: 10%;">Min.</th> <th style="width: 10%;">Typ.</th> <th style="width: 10%;">Max.</th> </tr> </thead> <tbody> <tr> <td>Color Chromaticity</td> <td>Green</td> <td>X</td> <td>0.34</td> <td>0.39</td> <td>0.44</td> </tr> </tbody> </table> <p style="text-align: center;">↓</p> <table border="1" style="width: 100%; border-collapse: collapse;"> <thead> <tr> <th style="width: 30%;">Item</th> <th style="width: 15%;">Symbol</th> <th style="width: 10%;">Min.</th> <th style="width: 10%;">Typ.</th> <th style="width: 10%;">Max.</th> </tr> </thead> <tbody> <tr> <td>Color Chromaticity</td> <td>Green</td> <td>X</td> <td>0.27</td> <td>0.32</td> <td>0.37</td> </tr> </tbody> </table>	Item	Symbol	Min.	Typ.	Max.	Color Chromaticity	Green	X	0.34	0.39	0.44	Item	Symbol	Min.	Typ.	Max.	Color Chromaticity	Green	X	0.27	0.32	0.37
Item	Symbol	Min.	Typ.	Max.																				
Color Chromaticity	Green	X	0.34	0.39	0.44																			
Item	Symbol	Min.	Typ.	Max.																				
Color Chromaticity	Green	X	0.27	0.32	0.37																			
May 01,'12	All pages	Company name changed: KAOHSIUNG HITACHI ELECTRONICS CO.,LTD. <p style="text-align: center;">↓</p> KAOHSIUNG OPTO-ELECTRONICS INC.																						
	7B64PS 2704 – TX14D16VM1CBC-3 Page 4 - 1/1	4. ABSOLUTE MAXIMUM RATINGS Revised : Note2																						
	7B64PS 2705 – TX14D16VM1CBC-3 Page 5 - 1/1	5.1 LCD CHARACTERISTICS Added : Note3																						

3. GENERAL DATA

3.1 DISPLAY FEATURES

This module is a 5.7" QVGA of 4:3 format amorphous silicon TFT. The pixel format is vertical stripe and sub pixels are arranged as R(red), G(green), B(blue) sequentially. This display is RoHS compliant, and COG (chip on glass) technology and LED backlight are applied on this display.

Part Name	TX14D16VM1CBC
Module Dimensions	131.0(W) mm x 102.2(H) mm x 10.9(D) mm typ.
LCD Active Area	115.2(W) mm x 86.4(H) mm
Dot Pitch	0.12(W) mm x 3(R, G, B)(W) x 0.36(H) mm
Resolution	320 x 3(RGB)(W) x 240(H) dots
Color Pixel Arrangement	R, G, B Vertical stripe
LCD Type	Transmissive Color TFT; Normally White
Display Type	Active Matrix
Number of Colors	262k Colors
Backlight	7 LEDs parallel x 3 serial (21 LEDs in total)
Weight	160g typ.
Interface	C-MOS; 18-bit RGB; 40 pins
Power Supply Voltage	3.3V for LCD; 12V for Backlight
Power Consumption	215 mW for LCD; 1.0 W for backlight
Viewing Direction	6 O'clock (without image inversion and least brightness change) 12 O'clock (contrast peak located at)

4. ABSOLUTE MAXIMUM RATINGS

Item	Symbol	Min.	Max.	Unit	Remarks
Supply Voltage	VDD	-0.3	4.0	V	-
Input Voltage of Logic	VI	-0.3	VDD+0.3	V	Note 1
Operating Temperature	Top	-20	70	°C	Note 2
Storage Temperature	Tst	-30	80	°C	Note 2

Note 1: The rating is defined for the signal voltages of the interface such as DTMG, DCLK and RGB data bus.

Note 2: The maximum rating is defined as above based on the chamber temperature, which might be different from ambient temperature after assembling the panel into the application. Moreover, some temperature-related phenomenon as below needed to be noticed:

- Background color, contrast and response time would be different in temperatures other than 25°C.
- Operating under high temperature will shorten LED lifetime.

5. ELECTRICAL CHARACTERISTICS

5.1 LCD CHARACTERISTICS

$T_a = 25\text{ }^\circ\text{C}$, $V_{SS} = 0\text{V}$

Item	Symbol	Condition	Min.	Typ.	Max.	Unit	Remarks
Power Supply Voltage	VDD	-	3.0	3.3	3.6	V	-
Input Voltage of Logic	VI	"H" level	0.8VDD	-	VDD	V	Note 1
		"L" level	VSS	-	0.2VDD		
Power Supply Current	IDD	VDD-VSS=3.3V	-	65	-	mA	Note 2
Vsync Frequency	f_v	-	-	60	68	Hz	-
Hsync Frequency	f_H	For QVGA Mode	13.1	15.2	17.7	KHz	-
		For VGA Mode	25.3	29.5	36.1		
DCLK Frequency	f_{CLK}	For QVGA Mode	4.85	5.85	7.0	MHz	-
		For VGA Mode	17.2	20.9	26.7		

Note 1: The rating is defined for the signal voltages of the interface such as DTMG, DCLK and RGB data bus.

Note 2: An all black check pattern is used when measuring IDD, f_v is set to 60 Hz.

Note 3: 0.4A fuse is applied in the module for IDD. For display activation and protection purpose, power supply is recommended larger than 1.0A to start the display and break fuse once any short circuit occurred.

5.2 BACKLIGHT CHARACTERISTICS

$T_a = 25\text{ }^\circ\text{C}$

Item	Symbol	Condition	Min.	Typ.	Max.	Unit	Remarks
LED Input Voltage	VLED	Backlight Unit	11.5	12.0	12.5	V	Note1
LED Forward Current	ILED	Backlight Unit	-	84	91	mA	-
LED Lifetime	-	84 mA	-	40K	-	hrs	Note 2

Note 1: Fig. 5.1 shows the LED backlight circuit. The circuit has 21 LEDs in total and R is 255Ω .

Note 2: The estimated lifetime is specified as the time to reduce 50% brightness by applying 84 mA at $25\text{ }^\circ\text{C}$.

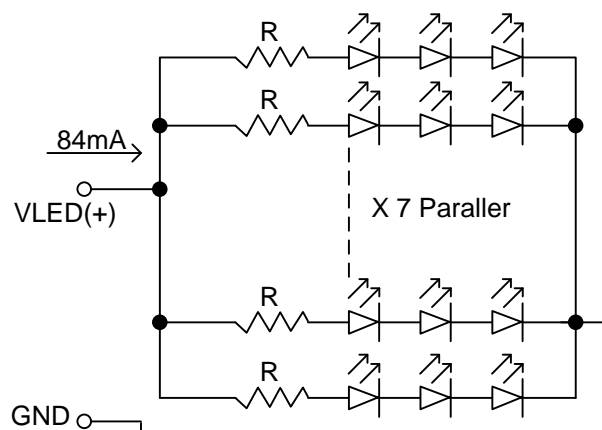

Fig 5.1

6. OPTICAL CHARACTERISTICS

The optical characteristics are measured based on the conditions as below:

- Supplying the signals and voltages defined in the section of electrical characteristics.
- The backlight unit needs to be turned on for 30 minutes.
- The ambient temperature is 25 °C .
- In the dark room around 500~1000 lx, the equipment has been set for the measurements as shown in Fig 6.1.

$$T_a = 25 \text{ }^\circ\text{C}, f_v = 60 \text{ Hz}, VDD = 3.3\text{V}$$

Item	Symbol	Condition	Min.	Typ.	Max.	Unit	Remarks	
Brightness of White	-	$\phi = 0^\circ, \theta = 0^\circ$, ILED= 84 mA	250	400	-	cd/m ²	Note 1	
Brightness Uniformity	-		70	-	-	%	Note 2	
Contrast Ratio	CR		120	350	-	-	Note 3	
Response Time		$\phi = 0^\circ, \theta = 0^\circ$	-	30	-	ms	-	
NTSC Ratio	-	$\phi = 0^\circ, \theta = 0^\circ$	-	45	-	%	-	
Viewing Angle	θ_x	$\phi = 0^\circ, CR \geq 5$	60	70	-	Degree	Note 5	
	$\theta_{x'}$	$\phi = 180^\circ, CR \geq 5$	60	70	-			
	θ_y	$\phi = 90^\circ, CR \geq 5$	70	80	-			
	$\theta_{y'}$	$\phi = 270^\circ, CR \geq 5$	60	70	-			
Color Chromaticity	Red	X	$\phi = 0^\circ, \theta = 0^\circ$	0.57	0.62	0.67	-	Note 6
		Y		0.31	0.36	0.41		
	Green	X		0.27	0.32	0.37		
		Y		0.52	0.57	0.62		
	Blue	X		0.10	0.15	0.20		
		Y		0.03	0.08	0.13		
	White	X		0.31	0.36	0.41		
		Y		0.30	0.35	0.40		

Note 1: The brightness is measured from the center point of the panel, P5 in Fig. 6.2, for the typical value.

Note 2: The brightness uniformity is calculated by the equation as below:

$$\text{Brightness uniformity} = \frac{\text{Max. Brightness or Min. Brightness} - \text{Average Brightness}}{\text{Average Brightness}} \times 100\%$$

, which is based on the brightness values of the 9 points measured by BM-5 as shown in Fig. 6.2.

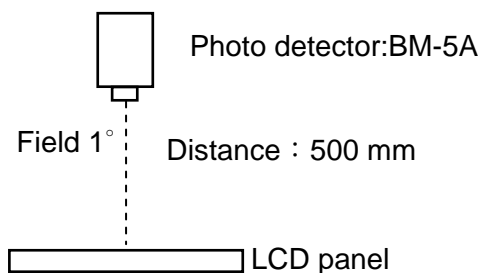

Fig. 6.1

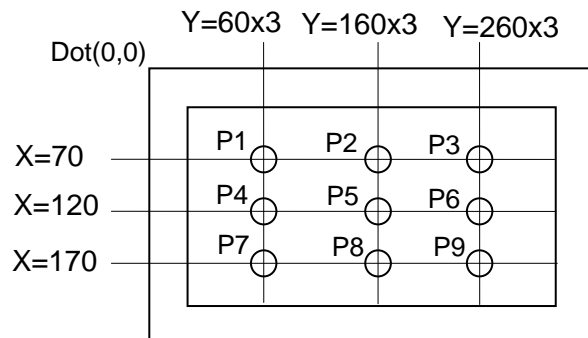

Fig. 6.2

Note 3: The Contrast ratio is measured from the center point of the panel, P5, and defined as the following equation:

$$CR = \frac{\text{Brightness of White}}{\text{Brightness of Black}}$$

Note 4: The definition of response time is shown in Fig. 6.3. The rising time is the period from 90% brightness to 10% brightness when the data is from white to black. Oppositely, Falling time is the period from 10% brightness rising to 90% brightness.

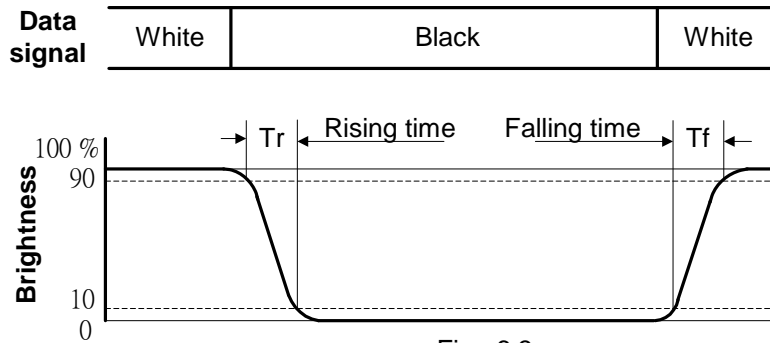

Fig . 6.3

Note 5: The definition of viewing angle is shown in Fig. 6.4. Angle ϕ is used to represent viewing directions, for instance, $\phi = 270^\circ$ means 6 o'clock, and $\phi = 0^\circ$ means 3 o'clock. Moreover, angle θ is used to represent viewing angles from axis Z toward plane XY.

The viewing direction of this display is 6 o'clock, which means that a photograph with gray scale would not be reversed in color and the brightness change would be less from this direction. However, the best contrast peak would be located at 12 o'clock.

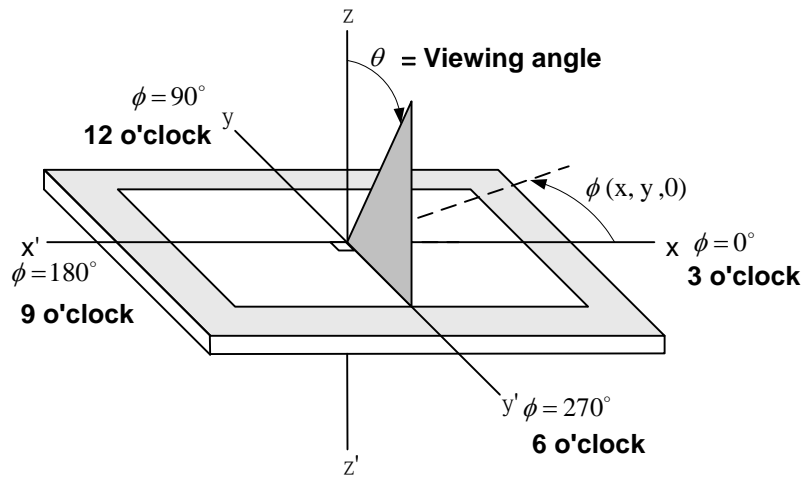
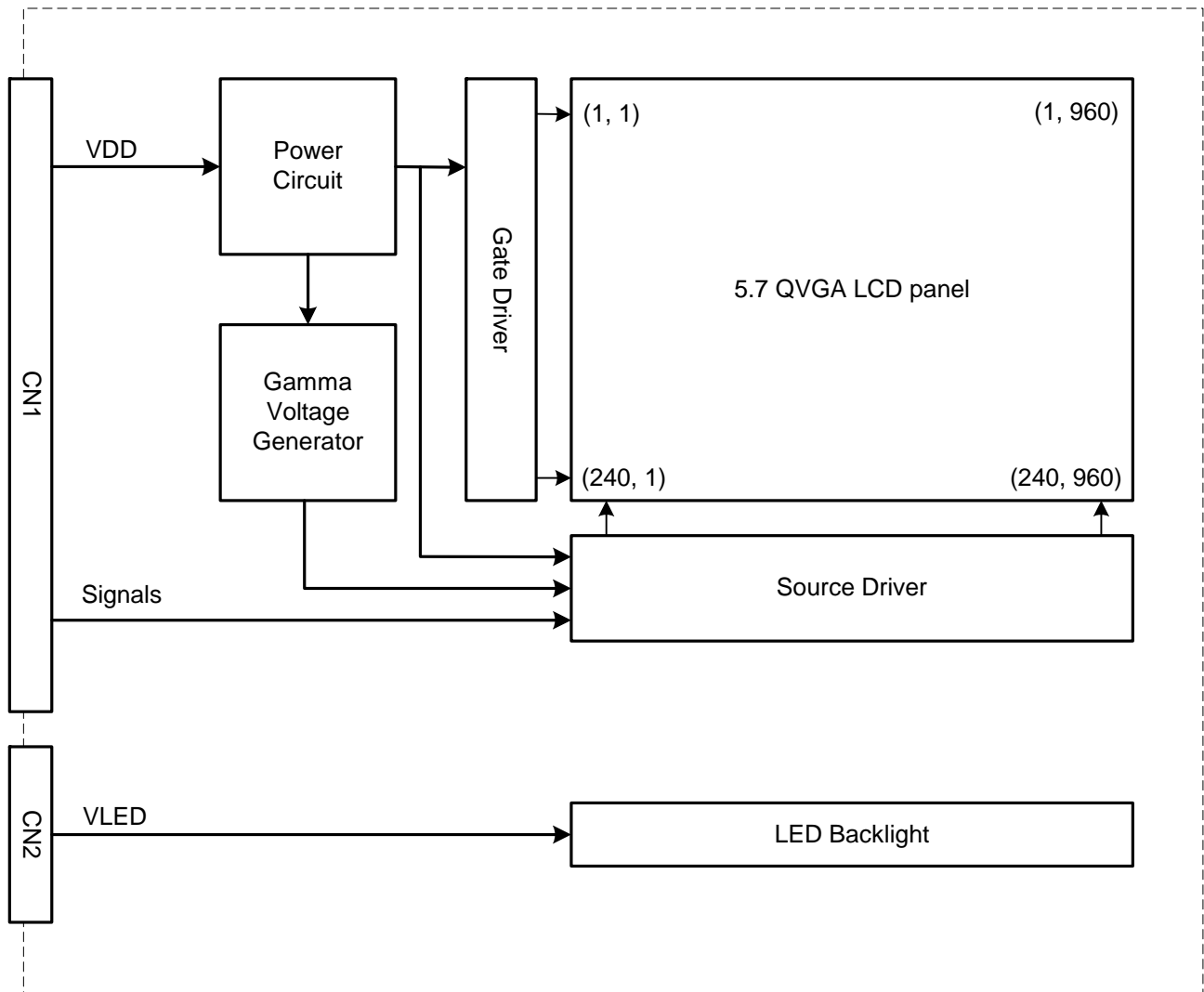

Fig. 6.4

Note 6: The color chromaticity is measured from the center point of the panel, P5, as shown in Fig. 6.2.

7. BLOCK DIAGRAM



Note 1: Signals are DCLK, DTMG, V/Q, Vsync, and RGB data bus.

8. RELIABILITY TESTS

Test Item	Condition	
High Temperature	1) Operating 2) 70 °C	240 hrs
Low Temperature	1) Operating 2) -20 °C	240 hrs
High Temperature	1) Storage 2) 80 °C	240 hrs
Low Temperature	1) Storage 2) -30 °C	240 hrs
Heat Cycle	1) Operating 2) -20 °C ~70 °C 3) 3hrs~1hr~3hrs	240 hrs
Thermal Shock	1) Non-Operating 2) -35 °C ↔ 85 °C 3) 0.5 hr ↔ 0.5 hr	240 hrs
High Temperature & Humidity	1) Operating 2) 40 °C & 85%RH 3) Without condensation (Note3)	240 hrs
Vibration	1) Non-Operating 2) 20~200 Hz 3) 2G 4) X, Y, and Z directions	1 hr for each direction
Mechanical Shock	1) Non-Operating 2) 10 ms 3) 50G 4) ±X, ±Y and ±Z directions	Once for each direction
ESD	1) Operating 2) Tip: 200 pF, 250 Ω 3) Air discharge for glass: ± 8KV 4) Contact discharge for metal frame: ± 8KV	1) Glass: 9 points 2) Metal frame: 8 points (Note4)

Note 1: Display functionalities are inspected under the conditions defined in the specification after the reliability tests.

Note 2: The display is not guaranteed for use in corrosive gas environments.

Note 3: Under the condition of high temperature & humidity, if the temperature is higher than 40 °C, the humidity needs to be reduced as Fig. 8.1 shown.

Note 4: All pins of LCD interface (CN1) have been tested by ±100V contact discharge of ESD under non-operating condition.

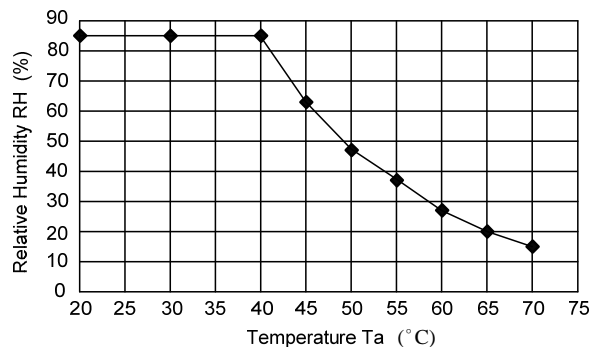

Fig. 8.1

9. LCD INTERFACE

9.1 INTERFACE PIN CONNECTIONS

The display interface connector is FA5B040HP1R3000 made by JAE (Thickness: $0.3 \pm 0.05\text{mm}$; Pitch: $0.5 \pm 0.05\text{mm}$) and more details of the connector are shown in the section of outline dimension.

Pin assignment of LCD interface is as below:

Pin No.	Signal	Function	Pin No.	Signal	Function
1	VDD	Power Supply for Logic	21	G4	Green Data
2	VDD		22	G3	
3	VDD		23	VSS	GND
4	VDD		24	G2	Green Data
5	NC	No Connection	25	G1	
6	DTMG	Timing Signal for Data	26	G0	GND
7	VSS	GND	27	VSS	
8	DCLK	Dot Clock	28	R5	Red Data
9	VSS	GND	29	R4	
10	V/Q	Selection Signal for VGA or QVGA ("H" = VGA, "L" or "NC" = QVGA)	30	R3	
11	VSS	GND	31	VSS	GND
12	B5	Blue Data	32	R2	Red Data
13	B4		33	R1	
14	B3		34	R0	
15	VSS	GND	35	(IC)	Note 1
16	B2	Blue Data	36	VSS	GND
17	B1		37	NC	No Connection
18	B0		38	NC	
19	VSS		GND	39	
20	G5	Green Data	40	NC	

Note 1: Keep open electrically , KOE test use only.

The backlight interface connector is BHR-03VS-1 made by JST, and pin assignment of backlight is as below:

Pin No.	Signal	Level	Function
1	V_{LED+}	-	Power Supply for LED
2	NC	-	No connection
3	V_{LED-}	-	GND

9.2 TIMING CHART

DTMG (Data Enable) is the signal to determine valid data, and the timing of DTMG can be determined from Hsync and Vsync as below. For this display, only DTMG and DCLK are the essential signals. Hsync and Vsync are not necessary to connect to display interface after DTMG has been generated and input.

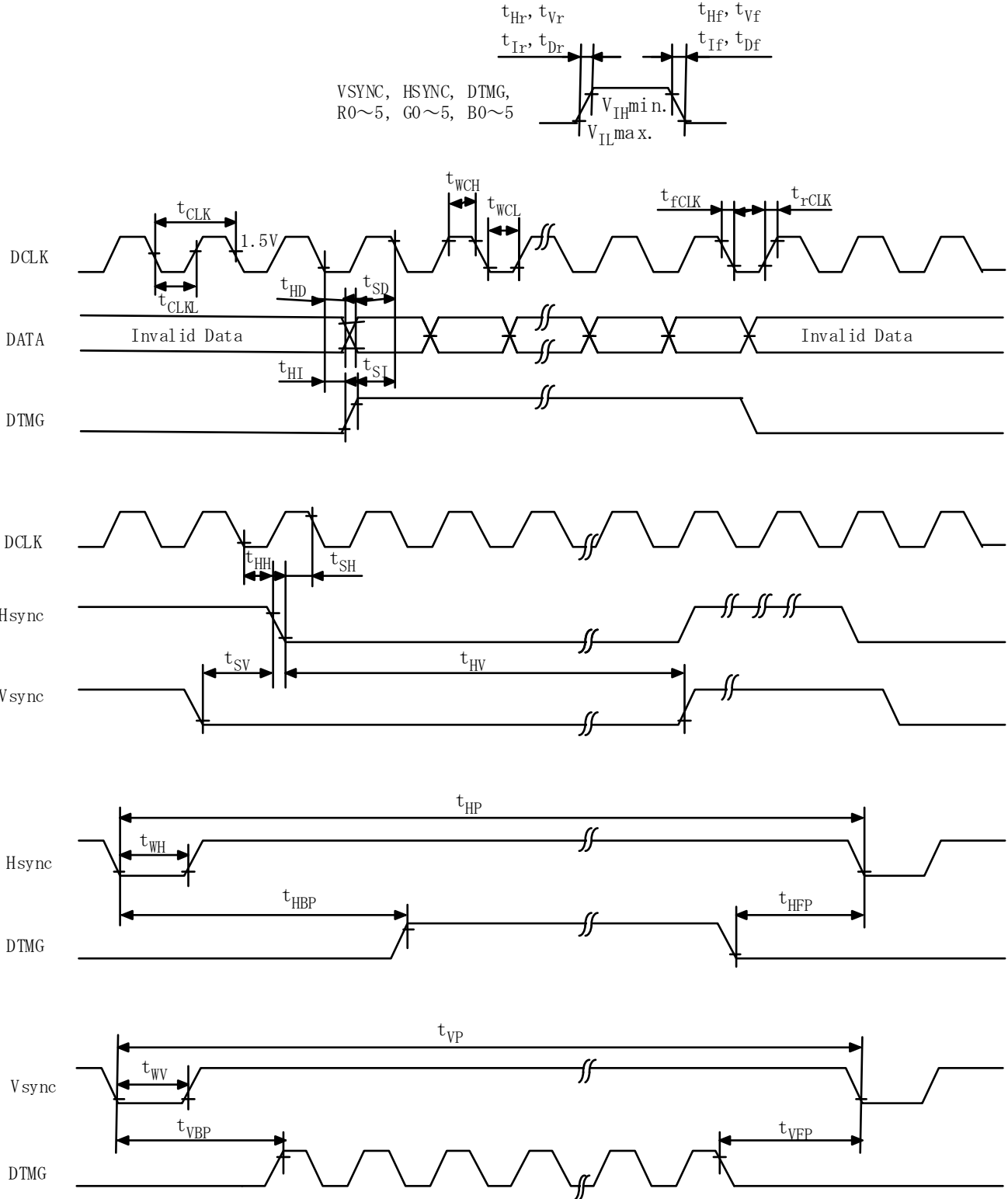

9.3 INTERFACE TIMING SPECIFICATIONS

9.3.1 INTERFACE TIMING FOR QVGA DISPLAY MODE

Item		Symbol	Min.	Typ.	Max.	Unit
DCLK	Cycle time	t_{CLK}	60	171	206	ns
	Low level Width	t_{WCL}	12	-	-	
	High level Width	t_{WCH}	12	-	-	
	Rise time	t_{rCLK}	-	-	20	
	Fall time	t_{fCLK}	-	-	20	
	Duty	D	0.45	0.5	0.55	-
Hsync	Set up time	t_{SH}	5	-	-	ns
	Hold time	t_{HH}	10	-	-	tCLK
	Cycle	t_{HP}	358	385	453	
	Valid width	t_{WH}	4	5	-	
	Rise/Fall time	t_{Hr}, t_{Hf}	-	-	30	ns
Vsync	Set up	t_{SV}	0	-	-	tCLK
	Hold	t_{HV}	2	-	-	tHP
	Cycle	t_{VP}	247	253	535	
	Valid width	t_{WV}	2	2	-	
	Rise/Fall time	t_{Vr}, t_{Vf}	-	-	50	ns
DTMG	Set up time	t_{SI}	5	-	-	ns
	Hold time	t_{HI}	10	-	-	tCLK
	Rise/Fall time	t_{Ir}, t_{If}	-	-	30	
	Horizontal back porch	t_{HBP}	24	35	99	
	Horizontal front porch	t_{HFP}	8	30	62	
	Vertical back porch	t_{VBP}	7	9	197	tHP
	Vertical front porch	t_{VFP}	2	4	97	
Data	Set up time	t_{SD}	5	-	-	ns
	Hold time	t_{HD}	10	-	-	ns
	Rise/Fall time	t_{Dr}, t_{Df}	-	-	20	

Note 1: Vsync needs to be set as odd numbers.

9.3.2 INTERFACE TIMING FOR VGA DISPLAY MODE

	Item	Symbol	Min.	Typ.	Max.	Unit
DCLK	Cycle time	t_{CLK}	37.4	47.8	58.1	ns
	Low level Width	t_{WCL}	15	-	-	
	High level Width	t_{WCH}	15	-	-	
	Rise time	t_{rCLK}	-	-	25	
	Fall time	t_{fCLK}	-	-	25	
	Duty	D	0.45	0.5	0.55	-
Hsync	Set up time	t_{SH}	5	-	-	ns
	Hold time	t_{HH}	10	-	-	tCLK
	Cycle	t_{HP}	679	709	739	
	Valid width	t_{WH}	4	5	5	
	Rise/Fall time	t_{Hr}, t_{Hf}	-	-	30	ns
Vsync	Set up	t_{SV}	0	-	-	tCLK
	Hold	t_{HV}	2	-	-	
	Cycle	t_{VP}	485	491	533	tHP
	Valid width	t_{WV}	2	2	2	ns
	Rise/Fall time	t_{Vr}, t_{Vf}	-	-	50	
DTMG	Set up time	t_{SI}	5	-	-	ns
	Hold time	t_{HI}	10	-	-	
	Rise/Fall time	t_{Ir}, t_{If}	-	-	30	ns
	Horizontal back porch	t_{HBP}	24	37	50	
	Horizontal front porch	t_{HFP}	15	32	49	tCLK
	Vertical back porch	t_{VBP}	4	7	28	
	Vertical front porch	t_{VFP}	1	4	25	tHP
Data	Set up time	t_{SD}	5	-	-	ns
	Hold time	t_{HD}	10	-	-	
	Rise/Fall time	t_{Dr}, t_{Df}	-	-	25	ns

Note 1: Vsync needs to be set as odd numbers.

9.4 POWER SEQUENCE

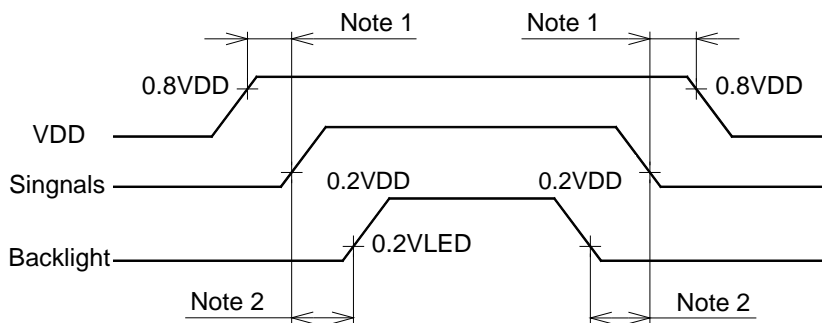

Fig. 9.1

Note 1: In order to avoid any damages, the correct power On sequence must be followed and VDD have to be applied before all other signals (DTMG, DCLK, RGB data). The opposite is true for power Off where VDD have to be remained on until all other signals have been switch off. The recommended time period is 1 second.

Note 2: In order to avoid showing uncompleted patterns in transient state. It is recommended that switching the backlight on is delayed for 1 second after the signals have been applied. The opposite is true for power Off where the backlight have to be switched off 1 second before the signals are removed.

9.5 DATA INPUT for DISPLAY COLOR

	COLOR & Gray Scale	Data Signal																	
		R5	R4	R3	R2	R1	R0	G5	G4	G3	G2	G1	G0	B5	B4	B3	B2	B1	B0
Basic Color	Black	0	0	0	0	0	0	0	0	0	0	0	0	0	0	0	0	0	0
	Red (0)	1	1	1	1	1	1	0	0	0	0	0	0	0	0	0	0	0	0
	Green (0)	0	0	0	0	0	0	1	1	1	1	1	1	0	0	0	0	0	0
	Blue (0)	0	0	0	0	0	0	0	0	0	0	0	0	1	1	1	1	1	1
	Cyan	0	0	0	0	0	0	1	1	1	1	1	1	1	1	1	1	1	1
	Magenta	1	1	1	1	1	1	0	0	0	0	0	0	1	1	1	1	1	1
	Yellow	1	1	1	1	1	1	1	1	1	1	1	1	0	0	0	0	0	0
	White	1	1	1	1	1	1	1	1	1	1	1	1	1	1	1	1	1	1
Red	Black	0	0	0	0	0	0	0	0	0	0	0	0	0	0	0	0	0	0
	Red (62)	0	0	0	0	0	1	0	0	0	0	0	0	0	0	0	0	0	0
	Red (61)	0	0	0	0	1	0	0	0	0	0	0	0	0	0	0	0	0	0
	:	:	:	:	:	:	:	:	:	:	:	:	:	:	:	:	:	:	:
	:	:	:	:	:	:	:	:	:	:	:	:	:	:	:	:	:	:	:
	Red (1)	1	1	1	1	1	0	0	0	0	0	0	0	0	0	0	0	0	0
Red (0)	1	1	1	1	1	1	0	0	0	0	0	0	0	0	0	0	0	0	
Green	Black	0	0	0	0	0	0	0	0	0	0	0	0	0	0	0	0	0	0
	Green (62)	0	0	0	0	0	0	0	0	0	0	1	0	0	0	0	0	0	0
	Green (61)	0	0	0	0	0	0	0	0	0	0	1	0	0	0	0	0	0	0
	:	:	:	:	:	:	:	:	:	:	:	:	:	:	:	:	:	:	:
	:	:	:	:	:	:	:	:	:	:	:	:	:	:	:	:	:	:	:
	Green (1)	0	0	0	0	0	0	1	1	1	1	1	0	0	0	0	0	0	0
Green (0)	0	0	0	0	0	0	1	1	1	1	1	1	0	0	0	0	0	0	
Blue	Black	0	0	0	0	0	0	0	0	0	0	0	0	0	0	0	0	0	0
	Blue (62)	0	0	0	0	0	0	0	0	0	0	0	0	0	0	0	0	0	1
	Blue (61)	0	0	0	0	0	0	0	0	0	0	0	0	0	0	0	0	1	0
	:	:	:	:	:	:	:	:	:	:	:	:	:	:	:	:	:	:	:
	:	:	:	:	:	:	:	:	:	:	:	:	:	:	:	:	:	:	:
	Blue (1)	0	0	0	0	0	0	0	0	0	0	0	0	1	1	1	1	1	0
Blue (0)	0	0	0	0	0	0	0	0	0	0	0	0	1	1	1	1	1	1	

10. OUTLINE DIMENSIONS

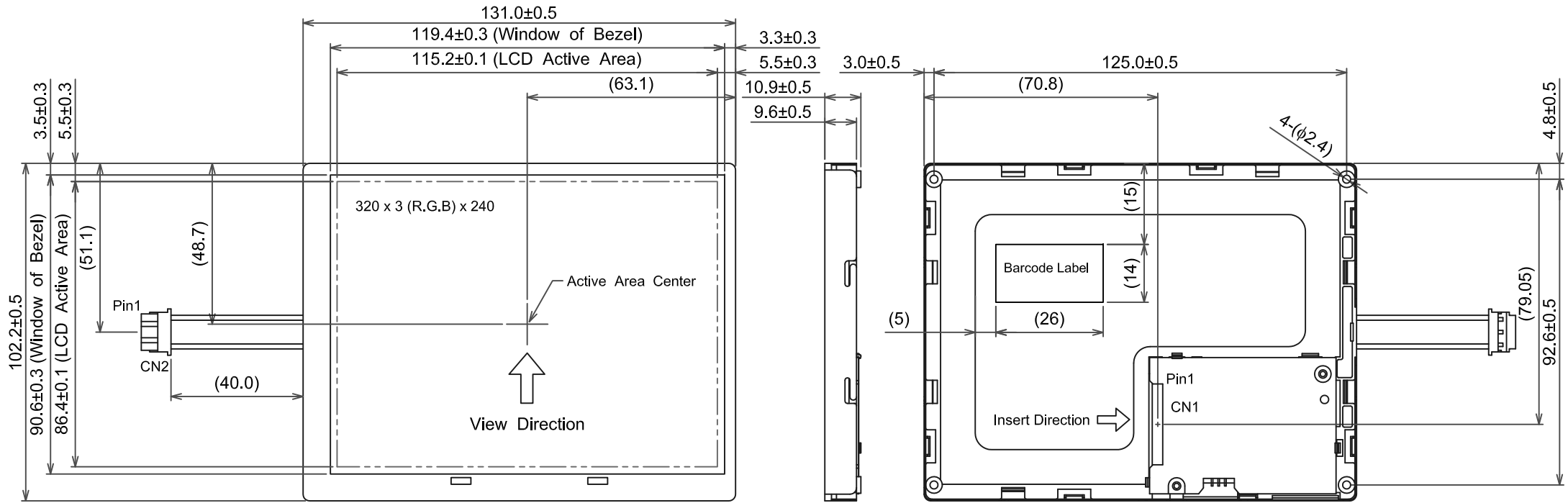

Recommended design rule for CN1 FPC

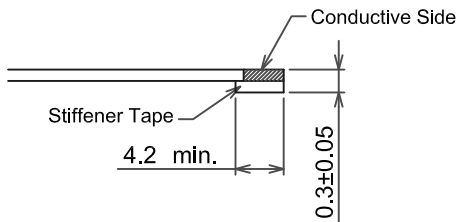
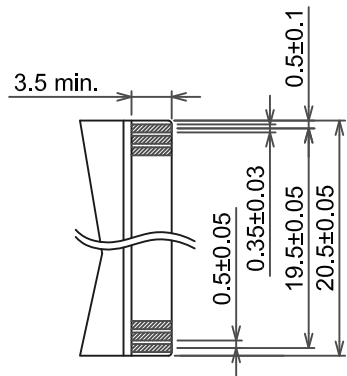

Scale : NTS
Unit : mm

11. APPEARANCE STANDARD

The appearance inspection is performed in a dark room around 500~1000 lx based on the conditions as below:

- The distance between inspector's eyes and display is 30 cm.
- The viewing zone is defined with angle θ shown in Fig. 11.1 The inspection should be performed within 45° when display is shut down. The inspection should be performed within 5° when display is power on.

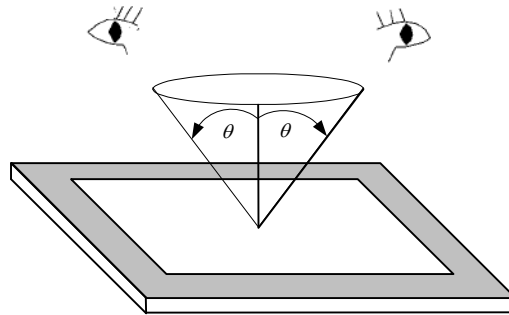

Fig 11.1

11.1 THE DEFINITION OF LCD ZONE

LCD panel is divided into 3 areas as shown in Fig.11.2 for appearance specification in next section. A zone is the LCD active area (dot area); B zone is the area, which extended 1 mm out from LCD active area; C zone is the area between B zone and metal frame.

In terms of housing design, B zone is the recommended window area customers' housing should be located in.

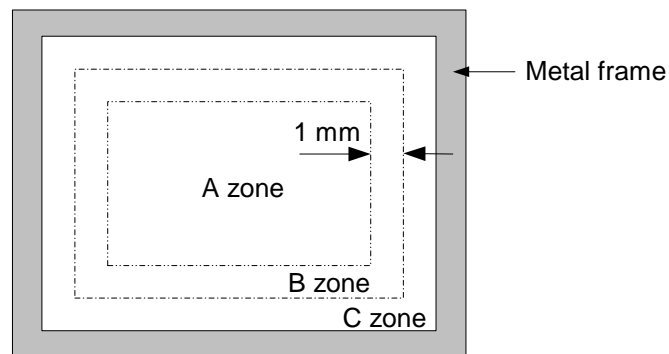

Fig 11.2

11.2 LCD APPEARANCE SPECIFICATION

The specification as below is defined as the amount of unexpected phenomenon or material in different zones of LCD panel. The definitions of length, width and average diameter using in the table are shown in Fig. 11.3 and Fig. 11.4.

Item	Criteria				Applied zone
	Length (mm)	Width (mm)	Maximum number	Minimum space	
Scratches	Ignored	$W \leq 0.02$	Ignored	-	A,B
	$L \leq 40$	$0.02 < W \leq 0.04$	10	-	
	$L \leq 20$	$W \leq 0.04$	10	-	
	Serious one is not allowed				
Dent	Serious one is not allowed				A
Wrinkles in polarizer	Serious one is not allowed				A
Bubbles on polarizer	Average diameter (mm)		Maximum number		A
	$D \leq 0.3$		Ignored		
	$0.3 < D \leq 0.5$		12		
	$0.5 < D$		3		
1) Stains 2) Foreign Materials 3) Dark Spot	Filamentous (Line shape)				A,B
	Length (mm)	Width (mm)	Maximum number		
	$L \leq 2.0$	$W \leq 0.03$	Ignored		
	$L \leq 3.0$	$0.03 < W \leq 0.05$	10		
	$L \leq 2.5$	$0.05 < W \leq 0.1$	1		
	Round (Dot shape)				A,B
	Average diameter (mm)	Maximum number	Minimum Space		
	$D < 0.2$	Ignored	-		
	$0.2 \leq D < 0.3$	10	10mm		
	$0.3 \leq D < 0.4$	5	30mm		
	$0.4 \leq D$	none	-		
	In total	Filamentous + Round=10			
	Those wiped out easily are acceptable				
	Dot-Defect (Note 1)			Type	Maximum number
Bright dot-defect		1 dot		4	
		2 adjacent dot		1	
		3 adjacent dot or above		Not allowed	
		In total		5	
Dark dot-defect		1 dot		5	
		2 adjacent dot		2	
		3 adjacent dot or above		Not allowed	
		In total		5	
In total			10		

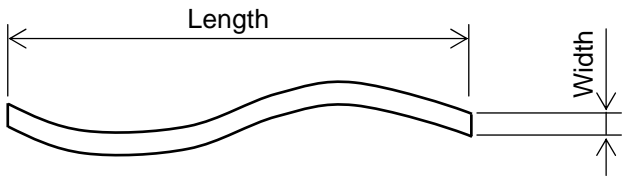
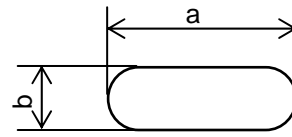

Fig 11.3



$$\text{Average diameter} = \frac{a+b}{2}$$

Fig 11.4

Note 1: The definitions of dot defect are as below:

- The defect area of the dot must be bigger than half of a dot.
- For bright dot-defect, showing black pattern, the dot's brightness must be over 30% brighter than others.
- For dark dot-defect, showing white pattern, the dot's brightness must be under 70% darker than others.
- The definition of 1-dot-defect is the defect-dot, which is isolated and no adjacent defect-dot.
- The definition of adjacent dot is shown as Fig. 11.5.
- The Density of dot defect is defined in the area within diameter $\phi = 20\text{mm}$.

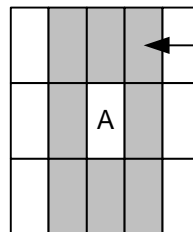

The dots colored gray are adjacent to defect-dot A.

Fig. 11.5

12. PRECAUTIONS

12.1 PRECAUTIONS of ESD

- 1) Before handling the display, please ensure your body has been connected to ground to avoid any damages by ESD. Also, do not touch display's interface directly when assembling.
- 2) Please remove the protection film very slowly before turning on the display to avoid generating ESD.

12.2 PRECAUTIONS of HANDLING

- 1) In order to keep the appearance of display in good condition, please do not rub any surfaces of the displays by sharp tools harder than 3H, especially touch panel, metal frame and polarizer.
- 2) Please do not stack the displays as this may damage the surface. In order to avoid any injuries, please avoid touching the edge of the glass or metal frame and wore gloves during handling.
- 3) Touching the polarizer or terminal pins with bare hand should be avoided to prevent staining and poor electrical contact.
- 4) Do not use any harmful chemicals such as acetone, toluene, and isopropyl alcohol to clean display's surfaces.
- 5) Please use soft cloth or absorbent cotton with ethanol to clean the display by gently wiping. Moreover, when wiping the display, please wipe it by horizontal or vertical direction instead of circling to prevent leaving scars on the display's surface, especially polarizer.
- 6) Please wipe any unknown liquids immediately such as saliva, water or dew on the display to avoid color fading or any permanently damages.
- 7) Maximum pressure to the surface of the display must be less than $1,96 \times 10^4$ Pa. If the area of adding pressure is less than 1 cm^2 , the maximum pressure must be less than 1.96N.

12.3 PRECAUTIONS OF OPERATING

- 1) Please input signals and voltages to the displays according to the values defined in the section of electrical characteristics to obtain the best performance. Any voltages over than absolute maximum rating will cause permanent damages to this display. Also, any timing of the signals out of this specification would cause unexpected performance.
- 2) When the display is operating at significant low temperature, the response time will be slower than it at 25°C . In high temperature, the color will be slightly dark and blue compared to original pattern. However, these are temperature-related phenomenon of LCD and it will not cause permanent damages to the display when used within the operating temperature.
- 3) The use of screen saver or sleep mode is recommended when static images are likely for long periods of time. This is to avoid the possibility of image sticking.
- 4) Spike noise can cause malfunction of the circuit. The recommended limitation of spike noise is no bigger than $\pm 100 \text{ mV}$.

12.4 PRECAUTIONS of STORAGE

If the displays are going to be stored for years, please be aware the following notices.

- 1) Please store the displays in a dark room to avoid any damages from sunlight and other sources of UV light.
- 2) The recommended long term storage temperature is between 10 C° ~35 C° and 55%~75% humidity to avoid causing bubbles between polarizer and LCD glasses, and polarizer peeling from LCD glasses.
- 3) It would be better to keep the displays in the container, which is shipped from KOE, and do not unpack it.
- 4) Please do not stick any labels on the display surface for a long time, especially on the polarizer.

13. DESIGNATION of LOT MARK

1) The lot mark is showing in Fig.13.3. First 4 digits are used to represent production lot, T represented made in Taiwan, and the last 5 digits are the serial number.

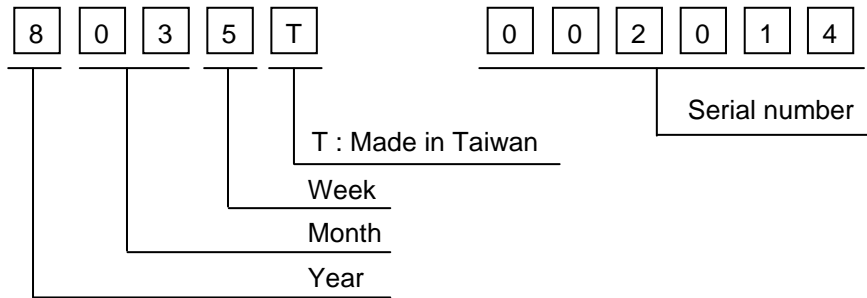

2) The tables as below are showing what the first 4 digits of lot mark are shorted for.

Year	Mark
2012	2
2013	3
2014	4
2015	5
2016	6

Month	Mark	Month	Mark
1	01	7	07
2	02	8	08
3	03	9	09
4	04	10	10
5	05	11	11
6	06	12	12

Week (Days)	Mark
1~7	1
8~14	2
15~21	3
22~28	4
29~31	5

3) Except letters I and O, revision number will be shown on lot mark and following letters A to Z.

4) The location of the lot mark is on the back of the display shown in Fig. 13.3.

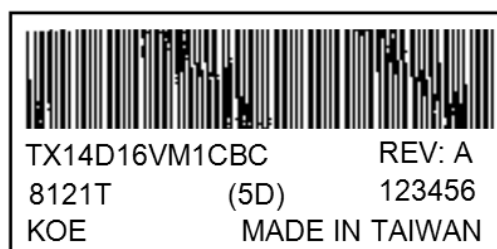

Fig 13.3