

# KOE

## JDI Group

Kaohsiung Opto-Electronics Inc.

FOR MESSRS: \_\_\_\_\_

DATE: Jun. 18<sup>th</sup>, 2012

### CUSTOMER'S ACCEPTANCE SPECIFICATIONS

## TX18D37VM0APA

### Contents

No.	ITEM	SHEET No.	PAGE
1	COVER	7B64PS 2701-TX18D37VM0APA-3	1-1/1
2	RECORD OF REVISION	7B64PS 2702-TX18D37VM0APA-3	2-1/1
3	GENERAL DATA	7B64PS 2703-TX18D37VM0APA-3	3-1/1
4	ABSOLUTE MAXIMUM RATINGS	7B64PS 2704-TX18D37VM0APA-3	4-1/1
5	ELECTRICAL CHARACTERISTICS	7B64PS 2705-TX18D37VM0APA-3	5-1/1
6	OPTICAL CHARACTERISTICS	7B64PS 2706-TX18D37VM0APA-3	6-1/2~2/2
7	BLOCK DIAGRAM	7B64PS 2707-TX18D37VM0APA-3	7-1/1
8	RELIABILITY TESTS	7B64PS 2708-TX18D37VM0APA-3	8-1/1
9	LCD INTERFACE	7B64PS 2709-TX18D37VM0APA-3	9-1/6~6/6
10	OUTLINE DIMENSIONS	7B64PS 2710-TX18D37VM0APA-3	10-1/2~2/2
11	TOUCH PANEL	7B64PS 2711-TX18D37VM0APA-3	11-1/2~2/2
12	APPEARANCE STANDARD	7B64PS 2712-TX18D37VM0APA-3	12-1/4~4/4
13	PRECAUTIONS	7B64PS 2713-TX18D37VM0APA-3	13-1/2~2/2
14	DESIGNATION OF LOT MARK	7B64PS 2714-TX18D37VM0APA-3	14-1/1

ACCEPTED BY: \_\_\_\_\_

PROPOSED BY: 

## 2. RECORD OF REVISION

DATE	SHEET No.	SUMMARY
May 01,'12	All pages	Company name changed: KAOHSIUNG HITACHI ELECTRONICS CO.,LTD. ↓ KAOHSIUNG OPTO-ELECTRONICS INC.
	7B64PS-2704- TX18D37VM0APA-2 Page 4-1/1	4. ABSOLUTE MAXIMUM RATINGS Revised : Note 2.
	7B64PS-2708- TX18D37VM0APA-2 Page 8-1/1	8. RELIABILITY TESTS Added : Note 4.
	7B64PS-2711- TX18D37VM0APA-2 Page 11-2/2	11.5 SAFETY AND ATTENTIONS Added : Item 6)
Jun. 18,'12	7B64PS-2711- TX18D37VM0APA-3 Page 11-1/2~2/2	11.2 ELECTRICAL CHARACTERISTICS Revised : X1-X2 : 310~1070Ω → 400~1200Ω  11.4 OPTICAL CHARACTERISTICS Revised : Specification : 80% min. → 77% min.

### 3. GENERAL DATA

#### 3.1 DISPLAY FEATURES

This module is a 7" WVGA of 16:9 format amorphous silicon TFT. The pixel format is vertical stripe and sub pixels are arranged as R (red), G (green), B (blue) sequentially. This display is RoHS compliant, COG (chip on glass) technology and LED backlight are applied on this display.

Part Name	TX18D37VM0APA
Module Dimensions	166.1(W) mm x 107.82(H) mm x 14.4 (D) mm typ.
LCD Active Area	152.4(W) mm x 91.44(H) mm
Pixel Pitch	0.1905(W) mm x 0.1905 (H) mm
Resolution	800 x 3(RGB)(W) x 480(H) dots
Color Pixel Arrangement	R, G, B Vertical stripe
LCD Type	Transmissive Color TFT; Normally Black
Display Type	Active Matrix
Number of Colors	262k Colors
Backlight	12 LEDs (3 series x 4)
Weight	300 typ. (g)
Interface	LVDS; 20 pins
Power Supply Voltage	3.3V for LCD; 12V for Backlight
Power Consumption	1.55W for LCD; 4.56W for Backlight
Viewing Direction	Super Wide Version (In-Plane Switching)
Touch Panel	Resistive type; Film on Glass; 4-wire type; Antiglare Surface

## 4. ABSOLUTE MAXIMUM RATINGS

Item	Symbol	Min.	Max.	Unit	Remarks
Supply Voltage	VDD	-0.3	3.6	V	-
Input Voltage of Logic	VI	-0.3	VDD+0.3	V	Note 1
Operating Temperature	Top	-20	70	°C	Note 2
Storage Temperature	Tst	-30	80	°C	Note 2
Backlight Input Voltage	VLED	-	15	V	-

Note 1: The rating is defined for the signal voltages of the interface such as CLK and pixel data pairs.

Note 2: The maximum rating is defined as above based on the chamber temperature, which might be different from ambient temperature after assembling the panel into the application. Moreover, some temperature-related phenomenon as below needed to be noticed:

- Background color, contrast and response time would be different in temperatures other than 25°C.
- Operating under high temperature will shorten LED lifetime.

## 5. ELECTRICAL CHARACTERISTICS

### 5.1 LCD CHARACTERISTICS

$T_a = 25\text{ }^\circ\text{C}$ ,  $V_{SS} = 0\text{V}$

Item	Symbol	Condition	Min.	Typ.	Max.	Unit	Remarks
Power Supply Voltage	VDD	-	3.0	3.3	3.6	V	-
Differential Input Voltage for LVDS Receiver Threshold	VI	"H" level	-	-	+100	mV	Note 1
		"L" level	-100	-	-		
Power Supply Current	IDD	VDD=3.3V	-	470	500	mA	Note 2
Vsync Frequency	$f_v$	-	-	60	75	Hz	-
Hsync Frequency	$f_H$	-	29	31.5	33	KHz	Note 3
CLK Frequency	$f_{CLK}$	-	30.0	33.0	36.0	MHz	

Note 1:  $V_{CM} = +1.2\text{V}$

$V_{CM}$  is common mode voltage of LVDS transmitter/receiver.

The input terminal of LVDS transmitter is terminated with  $100\Omega$ .

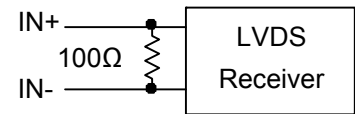

Note 2: An all white check pattern is used when measuring  $I_{DD}$ .  $f_v$  is set to 60 Hz.

Note 3: For LVDS transmitter input.

Note 4: 1.0A fuse is applied in the module for  $I_{DD}$ . For display activation and protection purpose, power supply is recommended larger than 2.5A to start the display and break fuse once any short circuit occurred.

### 5.2 BACKLIGHT CHARACTERISTICS

$T_a = 25\text{ }^\circ\text{C}$

Item	Symbol	Condition	Min.	Typ.	Max.	Unit	Remarks
LED Input Voltage	VLED	-	11.7	12	12.3	V	Note1
LED Forward Current (Dim Control)	ILED	0V; 0% duty	370	380	390	mA	Note 2
		3.3VDC; 100% duty	24	30	36		
LED lifetime	-	380 mA	-	70K	-	hrs	Note 3

Note 1: As Fig. 5.1 shown, LED current is constant, 380 mA, controlled by the LED driver when applying 12V VLED.

Note 2: Dimming function can be obtained by applying DC voltage or PWM signal from the display interface CN1. The recommended PWM signal is 1K ~ 10K Hz with 3.3V amplitude.

Note 3: The estimated lifetime is specified as the time to reduce 50% brightness by applying 380 mA at  $25\text{ }^\circ\text{C}$ .

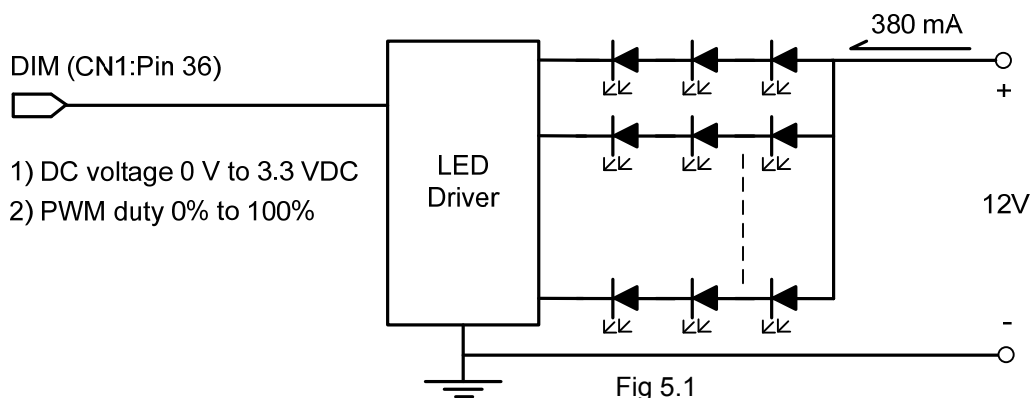

Fig 5.1

## 6. OPTICAL CHARACTERISTICS

The optical characteristics are measured based on the conditions as below:

- Supplying the signals and voltages defined in the section of electrical characteristics.
- The backlight unit needs to be turned on for 30 minutes.
- The ambient temperature is 25 °C .
- In the dark room around 500~1000 lx, the equipment has been set for the measurements as shown in Fig 6.1.

$$T_a = 25\text{ }^{\circ}\text{C}, f_v = 60\text{ Hz}, VDD = 3.3\text{V}$$

Item	Symbol	Condition	Min.	Typ.	Max.	Unit	Remarks	
Brightness of White	-	$\phi = 0^{\circ}, \theta = 0^{\circ}$ ,	270	360	-	cd/m <sup>2</sup>	Note 1	
Brightness Uniformity	-	ILED= 90	70	-	-	%	Note 2	
Contrast Ratio	CR	mA/series	-	600	-	-	Note 3	
Response Time (Rising + Falling)	$T_r + T_f$	$\phi = 0^{\circ}, \theta = 0^{\circ}$	-	-	45	ms	Note 4	
Viewing Angle	$\theta_x$	$\phi = 0^{\circ}, CR \geq 10$	-	85	-	Degree	Note 5	
	$\theta_{x'}$	$\phi = 180^{\circ}, CR \geq 10$	-	85	-			
	$\theta_y$	$\phi = 90^{\circ}, CR \geq 10$	-	85	-			
	$\theta_{y'}$	$\phi = 270^{\circ}, CR \geq 10$	-	85	-			
Color Chromaticity	Red	X	$\phi = 0^{\circ}, \theta = 0^{\circ}$	0.55	0.60	0.65	-	Note 6
		Y		0.31	0.36	0.41		
	Green	X		0.31	0.36	0.41		
		Y		0.54	0.59	0.64		
	Blue	X		0.10	0.15	0.20		
		Y		0.07	0.12	0.17		
	White	X		0.27	0.32	0.37		
		Y		0.29	0.34	0.39		

Note 1: The brightness is measured from the panel center point, P5 in Fig. 6.2, for the typical value.

Note 2: The brightness uniformity is calculated by the equation as below:

$$\text{Brightness uniformity} = \frac{\text{Min. Brightness}}{\text{Max. Brightness}} \times 100\%$$

, which is based on the brightness values of the 9 points measured by BM-5 as shown in Fig. 6.2.

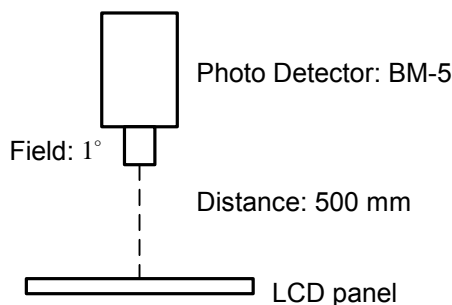

Fig. 6.1

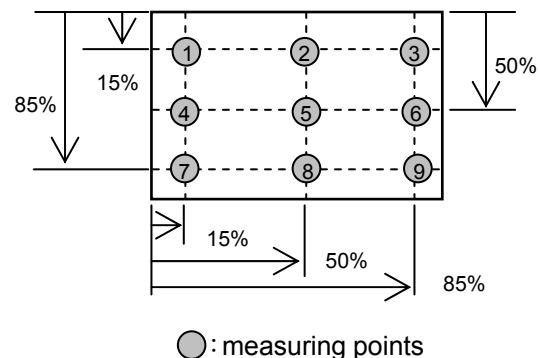
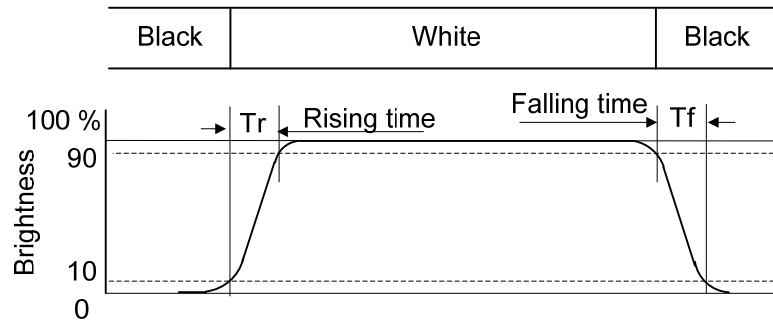

Fig. 6.2

Note 3: The Contrast Ratio is measured from the center point of the panel, P5, and defined as the following equation:

$$CR = \frac{\text{Brightness of White}}{\text{Brightness of Black}}$$

Note 4: The definition of response time is shown in Fig. 6.3. The rising time is the period from 10% brightness to 90% brightness when the data is from black to white. Oppositely, Falling time is the period from 90% brightness rising to 10% brightness.



Note 5: The definition of viewing angle is shown in Fig. 6.4. Angle  $\phi$  is used to represent viewing directions, for instance,  $\phi = 270^\circ$  means 6 o'clock, and  $\phi = 0^\circ$  means 3 o'clock. Moreover, angle  $\theta$  is used to represent viewing angles from axis Z toward plane XY.

The display is super wide viewing angle version, so that the best optical performance can be obtained from every viewing direction.

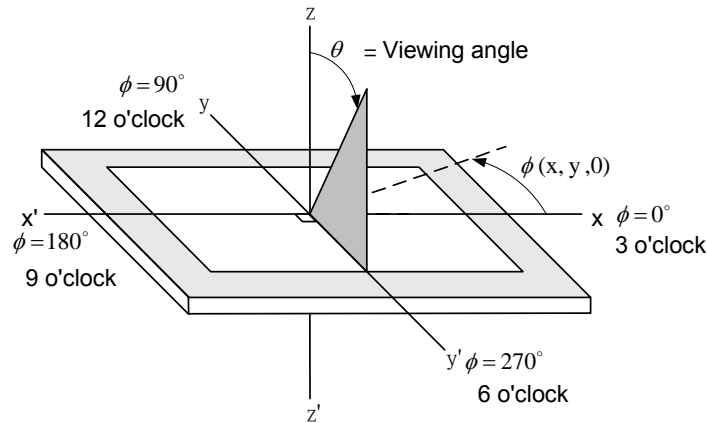
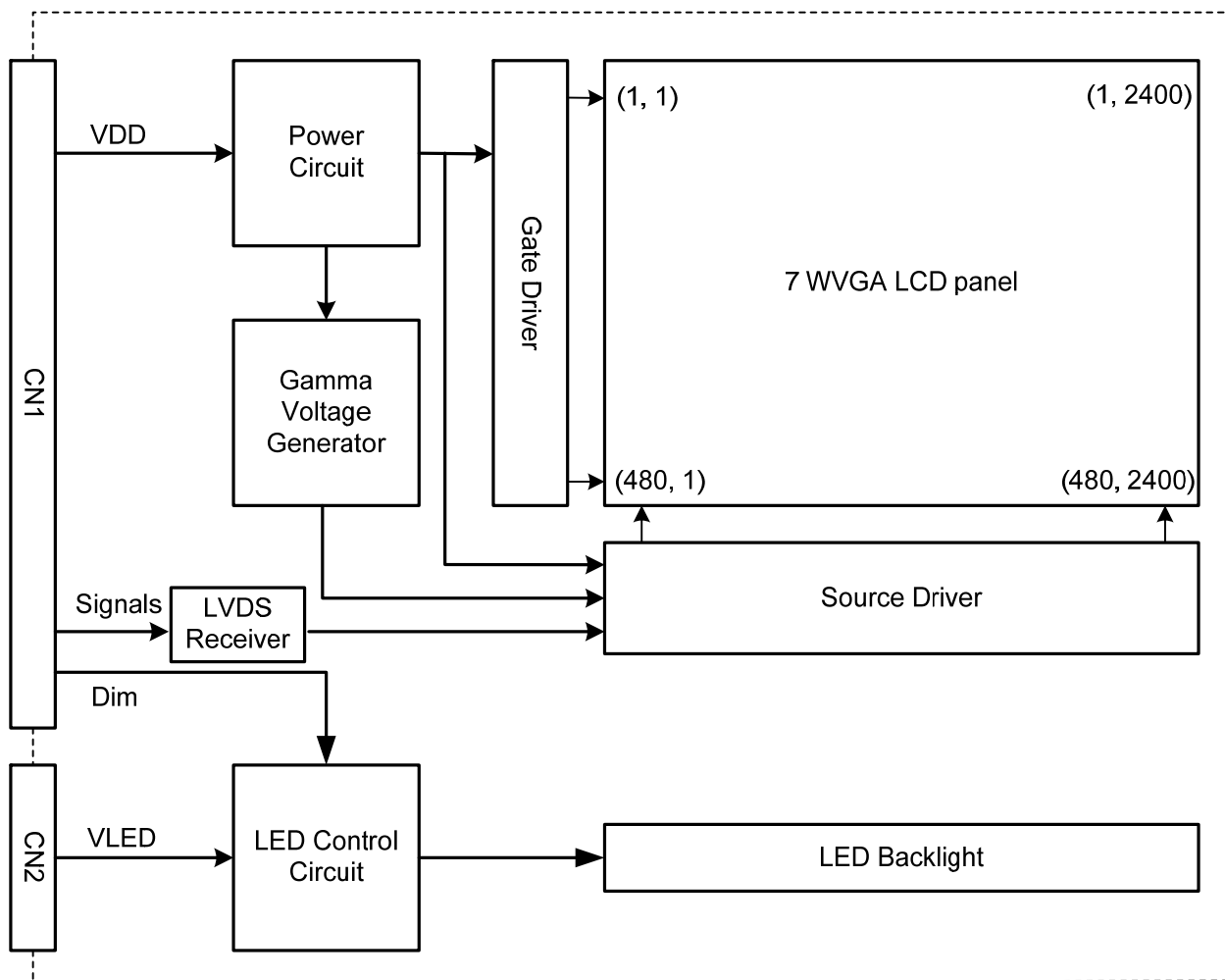

Fig 6.4

Note 6: The color chromaticity is measured from the center point of the panel, P5, as shown in Fig. 6.2.

# 7. BLOCK DIAGRAM



Note1: Signals are CLK and pixel data pairs.



## 8. RELIABILITY TESTS

Test Item	Condition	
High Temperature	1) Operating 2) 70 °C	240 hrs
Low Temperature	1) Operating 2) -20 °C	240 hrs
High Temperature	1) Storage 2) 80 °C	240 hrs
Low Temperature	1) Storage 2) -30 °C	240 hrs
Heat Cycle	1) Operating 2) -20 °C ↔ 70 °C 3) 1hrs~2hr~1hrs	200 cycles
Thermal Shock	1) Non-Operating 2) -30 °C ↔ 80 °C 3) 0.5 hr ↔ 0.5 hr	240 hrs
High Temperature & Humidity	1) Operating 2) 40 °C & 85%RH 3) Without condensation (Note4)	240 hrs
Vibration	1) Non-Operating 2) 10~150 Hz 3) 2G 4) X, Y, and Z directions	once for each direction
Mechanical Shock	1) Non-Operating 2) 10 ms 3) 50G 4) ±X, ±Y and ±Z directions	Once for each direction
ESD	1) Operating 2) Tip: 200 pF, 250 Ω 3) Air discharge for glass: ± 8KV 4) Contact discharge for metal frame: ± 8KV	1) Glass: 9 points 2) Metal frame: 8 points (Note3)

Note 1: Display functionalities are inspected under the conditions defined in the specification after the reliability tests.

Note 2: The display is not guaranteed for use in corrosive gas environments.

Note 3: All pins of LCD interface(CN1) have been tested by ± 100V contact discharge of ESD under non-operating condition.

Note 4: Under the condition of high temperature & humidity, if the temperature is higher than 40 °C, the humidity needs to be reduced as Fig. 8.1 shown.

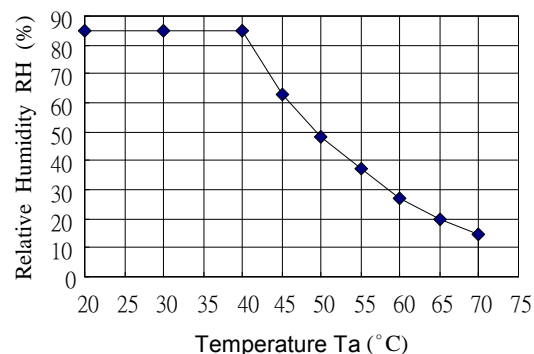

Fig. 8.1

## 9. LCD INTERFACE

### 9.1 INTERFACE PIN CONNECTIONS

The display interface connector (CN1) is FI-SEB20P-HF13E made by JAE and Pin assignment is as below:

Pin No.	Symbol	Signal	Pin No.	Symbol	Signal
1	VDD	Power Supply for Logic	11	IN2-	B2~B5, DE
2	VDD		12	IN2+	
3	VSS	GND	13	VSS	GND
4	VSS		14	CLK IN-	Pixel Clock
5	IN0-	R0~R5, G0	15	CLK IN+	
6	IN0+		16	VSS	GND
7	VSS	GND	17	IN3-	GND
8	IN1-	G1~G5, B0~B1	18	IN3+	GND
9	IN1+		19	VSS	GND
10	VSS	GND	20	DIM	Note 2

Note 1: IN n- and IN n+ (n=0, 1, 2), CLK IN- and CLK IN+ should be wired by twist-pairs or side-by-side FPC patterns, respectively.

Note 2: Normal brightness: 0V or 0% PWM duty; Brightness control: 0V to 3.3V DC or 0% to 100% PWM duty.

The backlight connector (CN2) is SM02(8.0)B-BHS-1-TB(LF)(SN), and pin assignment is as below:

Pin No.	Signal	Signal
1	VLED	12VDC
2	GND	Ground

## 9.2 LVDS INTERFACE

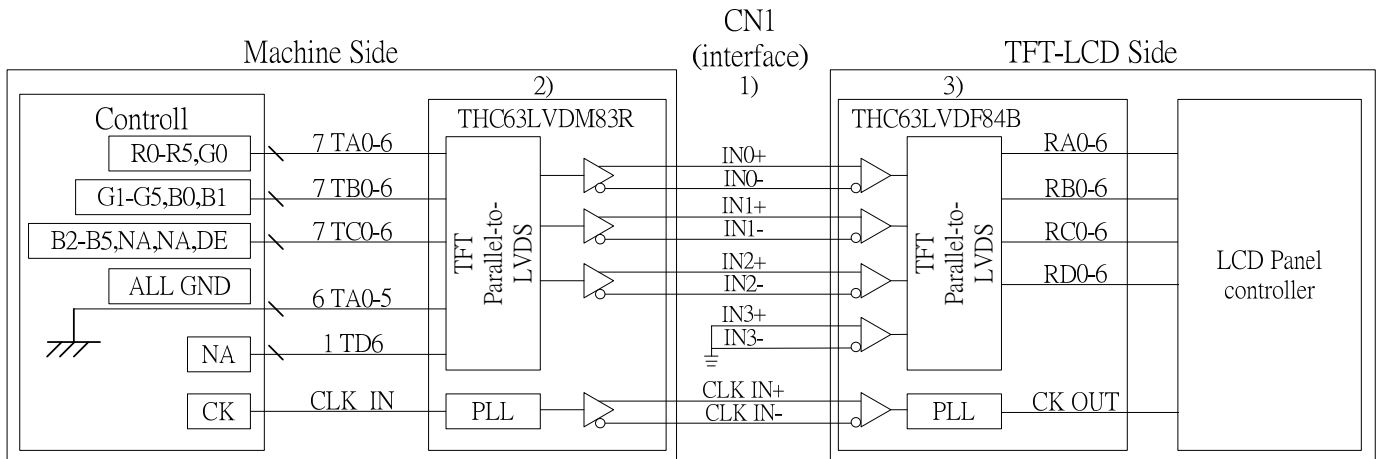

Note 1: LVDS cable impedance should be 100 ohms per signal line when each 2-lines (+, -) is used in differential mode.

Note 2: The recommended transmitter, THC63LVDM83R, is made by Thine or equivalent, which is not contained in the module.

Note 3: The receiver built-in the module is THC63LVDF84B made by Thine.

## 9.3 LVDS DATA FORMAT

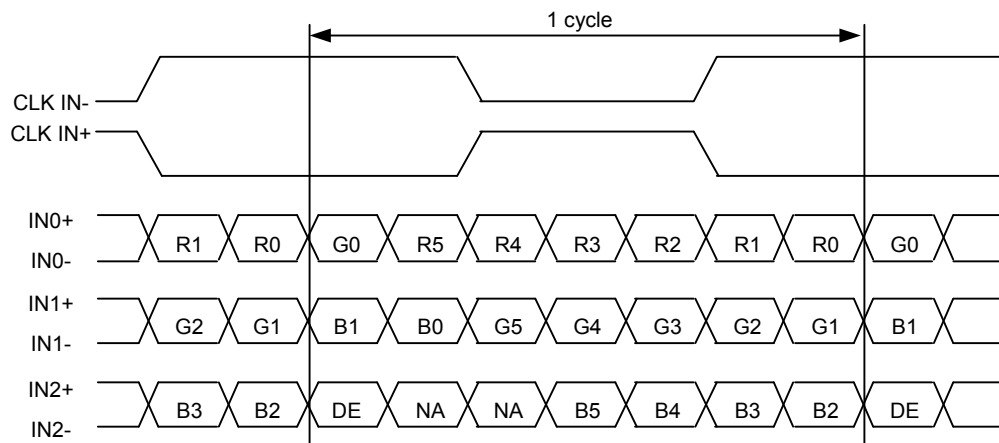

DE: Data Enable

NA: Not Available

### 9.4 TIMING CHART

DTMG (Data Enable) is the signal to determine valid data, and the timing of DTMG can be determined from Hsync and Vsync as below. For this display, only DTMG and DCLK are the essential signals. Hsync and Vsync are not necessary to connect to display interface after DTMG has been generated and input.

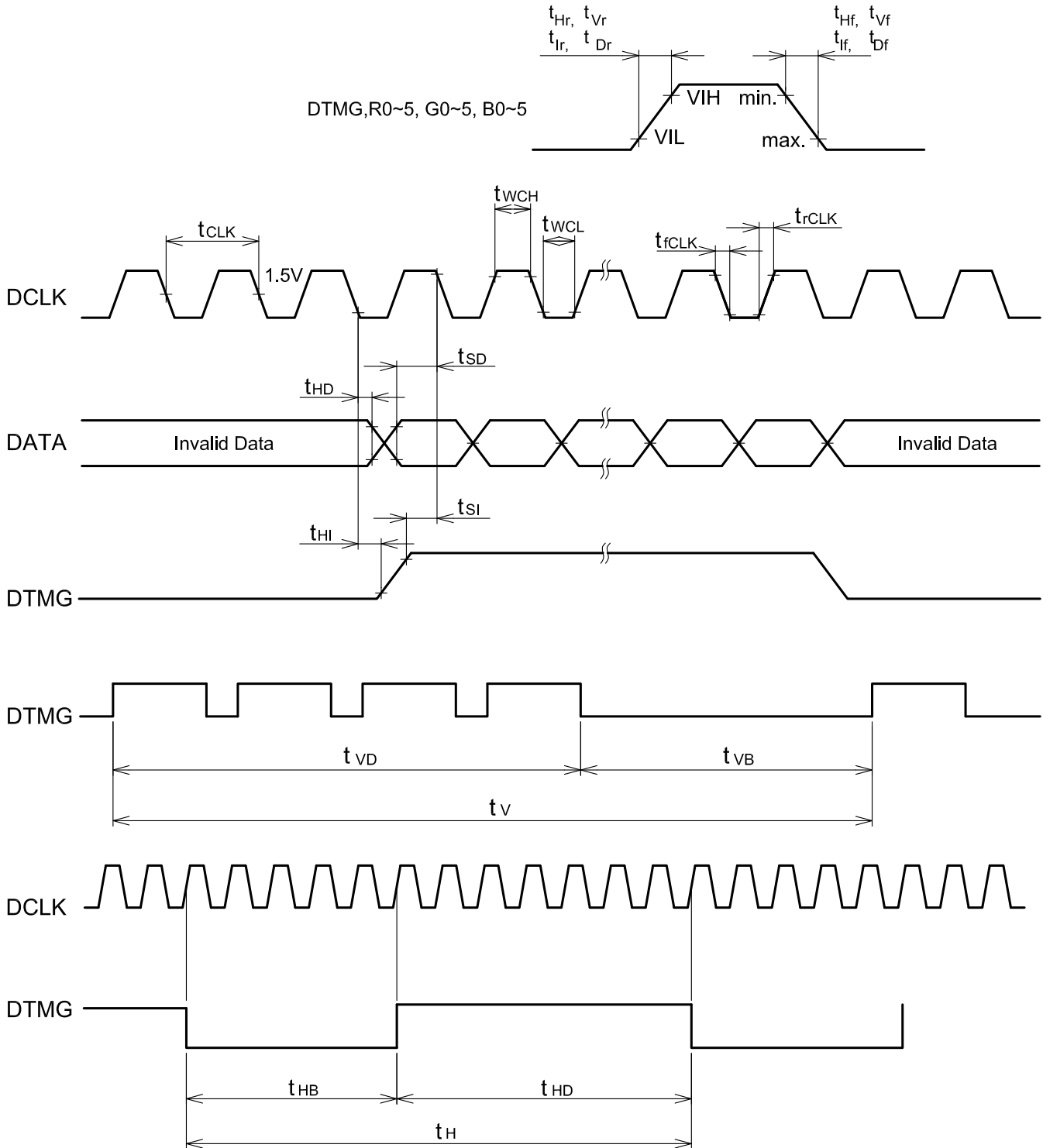

Data is latched by DCLK'S falling edge

## 9.5 INTERFACE TIMING SPECIFICATIONS

Item		Symbol	Min.	Typ.	Max.	Unit
DCLK	Frequency	$1/t_{CLK}$	30	33	36	MHz
	Low level Width	$t_{WCL}$	8	-	-	ns
	High level Width	$t_{WCH}$	8	-	-	
	Rise time	$t_{rCLK}$	-	-	4	
	Fall time	$t_{fCLK}$	-	-	4	
	Duty	D	0.45	0.5	0.55	
DTMG	Set up time	$t_{SI}$	4	-	-	ns
	Hold time	$t_{HI}$	4	-	-	
	Rise/Fall time	$t_{r}, t_{f}$	-	-	4	ns
	Horizontal cycle	$t_{HP}$	1035	1056	1090	tCLK
	Horizontal back porch	$t_{HBP}$	10	216	-	
	Horizontal front porch	$t_{HFP}$	30	40	-	
	Vertical cycle	$t_{VP}$	483	525	550	tHP
	Vertical back porch	$t_{VBP}$	2	34	-	
	Vertical front porch	$t_{VFP}$	1	11	-	
Data	Set up time	tSD	4	-	-	ns
	Hold time	tHD	4	-	-	
	Rise / Fall time	tDr, tDf	-	-	4	ns

## 9.6 LVDS RECEIVER TIMING

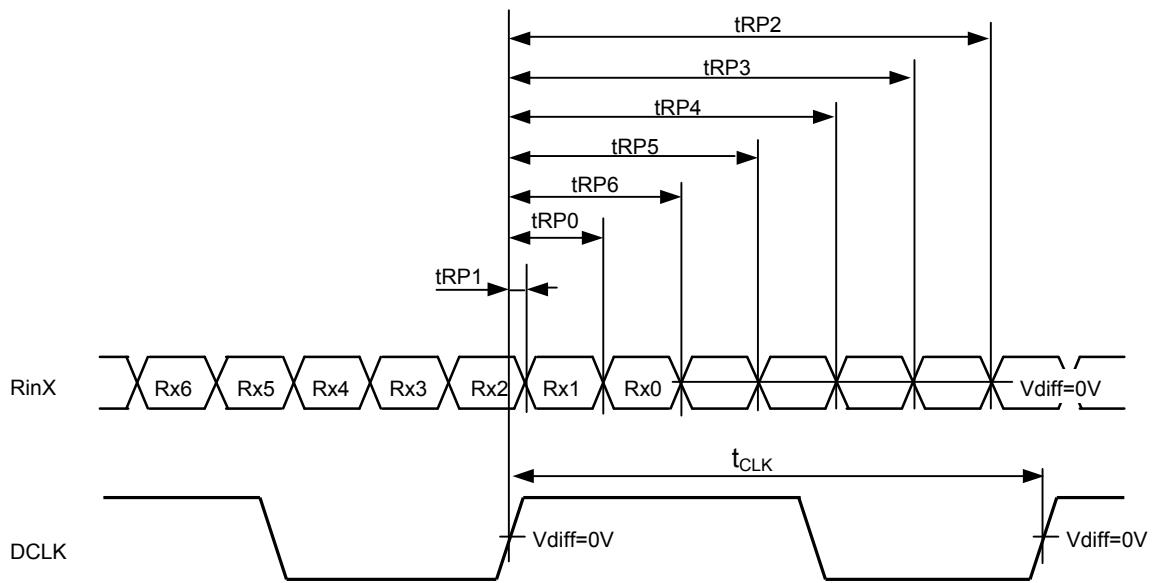

$$RinX = (RinX+) - (RinX-) \quad (X=0, 1, 2)$$

Item	Symbol	Min.	Typ.	Max.	Unit	
DCLK	Frequency	$1/t_{CLK}$	30	33	36	MHz
RinX (X=0,1,2)	0 data position	$t_{RP0}$	$1/7 * t_{CLK} - 0.49$	$1/7 * t_{CLK}$	$1/7 * t_{CLK} + 0.49$	ns
	1st data position	$t_{RP1}$	-0.49	0	+0.49	
	2nd data position	$t_{RP2}$	$6/7 * t_{CLK} - 0.49$	$6/7 * t_{CLK}$	$6/7 * t_{CLK} + 0.49$	
	3rd data position	$t_{RP3}$	$5/7 * t_{CLK} - 0.49$	$5/7 * t_{CLK}$	$5/7 * t_{CLK} + 0.49$	
	4th data position	$t_{RP4}$	$4/7 * t_{CLK} - 0.49$	$4/7 * t_{CLK}$	$4/7 * t_{CLK} + 0.49$	
	5th data position	$t_{RP5}$	$3/7 * t_{CLK} - 0.49$	$3/7 * t_{CLK}$	$3/7 * t_{CLK} + 0.49$	
	6th data position	$t_{RP6}$	$2/7 * t_{CLK} - 0.49$	$2/7 * t_{CLK}$	$2/7 * t_{CLK} + 0.49$	

## 9.7 DATA INPUT for DISPLAY COLOR

	COLOR & Gray Scale	Data Signal																	
		R5	R4	R3	R2	R1	R0	G5	G4	G3	G2	G1	G0	B5	B4	B3	B2	B1	B0
Basic Color	Black	0	0	0	0	0	0	0	0	0	0	0	0	0	0	0	0	0	0
	Red (63)	1	1	1	1	1	1	0	0	0	0	0	0	0	0	0	0	0	0
	Green (63)	0	0	0	0	0	0	1	1	1	1	1	1	0	0	0	0	0	0
	Blue (63)	0	0	0	0	0	0	0	0	0	0	0	0	1	1	1	1	1	1
	Cyan	0	0	0	0	0	0	1	1	1	1	1	1	1	1	1	1	1	1
	Magenta	1	1	1	1	1	1	0	0	0	0	0	0	1	1	1	1	1	1
	Yellow	1	1	1	1	1	1	1	1	1	1	1	1	0	0	0	0	0	0
	White	1	1	1	1	1	1	1	1	1	1	1	1	1	1	1	1	1	1
Red	Red (0)	0	0	0	0	0	0	0	0	0	0	0	0	0	0	0	0	0	0
	Red (1)	0	0	0	0	0	1	0	0	0	0	0	0	0	0	0	0	0	0
	:	:	:	:	:	:	:	:	:	:	:	:	:	:	:	:	:	:	:
	:	:	:	:	:	:	:	:	:	:	:	:	:	:	:	:	:	:	:
	Red (62)	1	1	1	1	1	0	0	0	0	0	0	0	0	0	0	0	0	0
	Red (63)	1	1	1	1	1	1	0	0	0	0	0	0	0	0	0	0	0	0
Green	Green (0)	0	0	0	0	0	0	0	0	0	0	0	0	0	0	0	0	0	0
	Green (1)	0	0	0	0	0	0	0	0	0	0	1	0	0	0	0	0	0	0
	:	:	:	:	:	:	:	:	:	:	:	:	:	:	:	:	:	:	:
	:	:	:	:	:	:	:	:	:	:	:	:	:	:	:	:	:	:	:
	Green (62)	0	0	0	0	0	0	1	1	1	1	1	0	0	0	0	0	0	0
	Green (63)	0	0	0	0	0	0	1	1	1	1	1	1	0	0	0	0	0	0
Blue	Blue (0)	0	0	0	0	0	0	0	0	0	0	0	0	0	0	0	0	0	0
	Blue (1)	0	0	0	0	0	0	0	0	0	0	0	0	0	0	0	0	0	1
	:	:	:	:	:	:	:	:	:	:	:	:	:	:	:	:	:	:	:
	:	:	:	:	:	:	:	:	:	:	:	:	:	:	:	:	:	:	:
	Blue (62)	0	0	0	0	0	0	0	0	0	0	0	0	1	1	1	1	1	0
	Blue (63)	0	0	0	0	0	0	0	0	0	0	0	0	1	1	1	1	1	1

## 9.8 POWER SEQUENCE

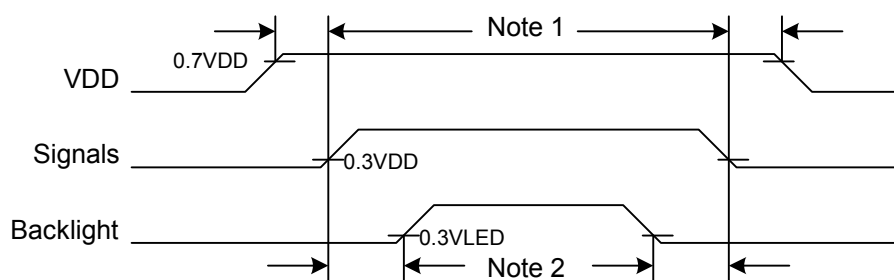

Fig. 8.7 Power Sequence Timing

Note 1: In order to avoid any damages, VDD has to be applied before all other signals. The opposite is true for power off where VDD has to be remained on until all other signals have been switch off. The recommended time period is 1 second.

Note 2: In order to avoid showing uncompleted patterns in transient state. It is recommended that switching the backlight on is delayed for 1 second after the signals have been applied. The opposite is true for power off where the backlight has to be switched off 1 second before the signals are removed.

# 10. OUTLINE DIMENSIONS

## 10.1 FRONT VIEW

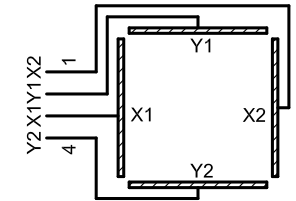
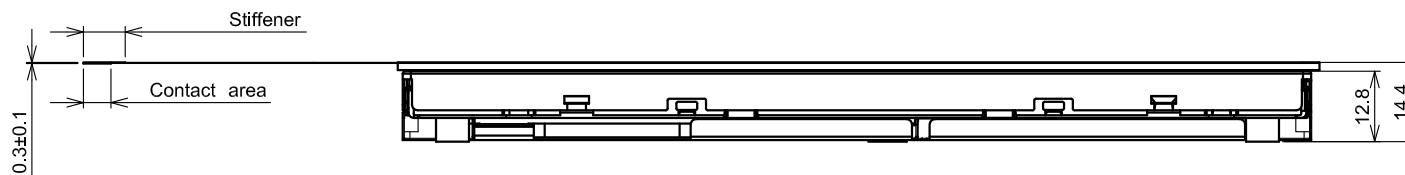
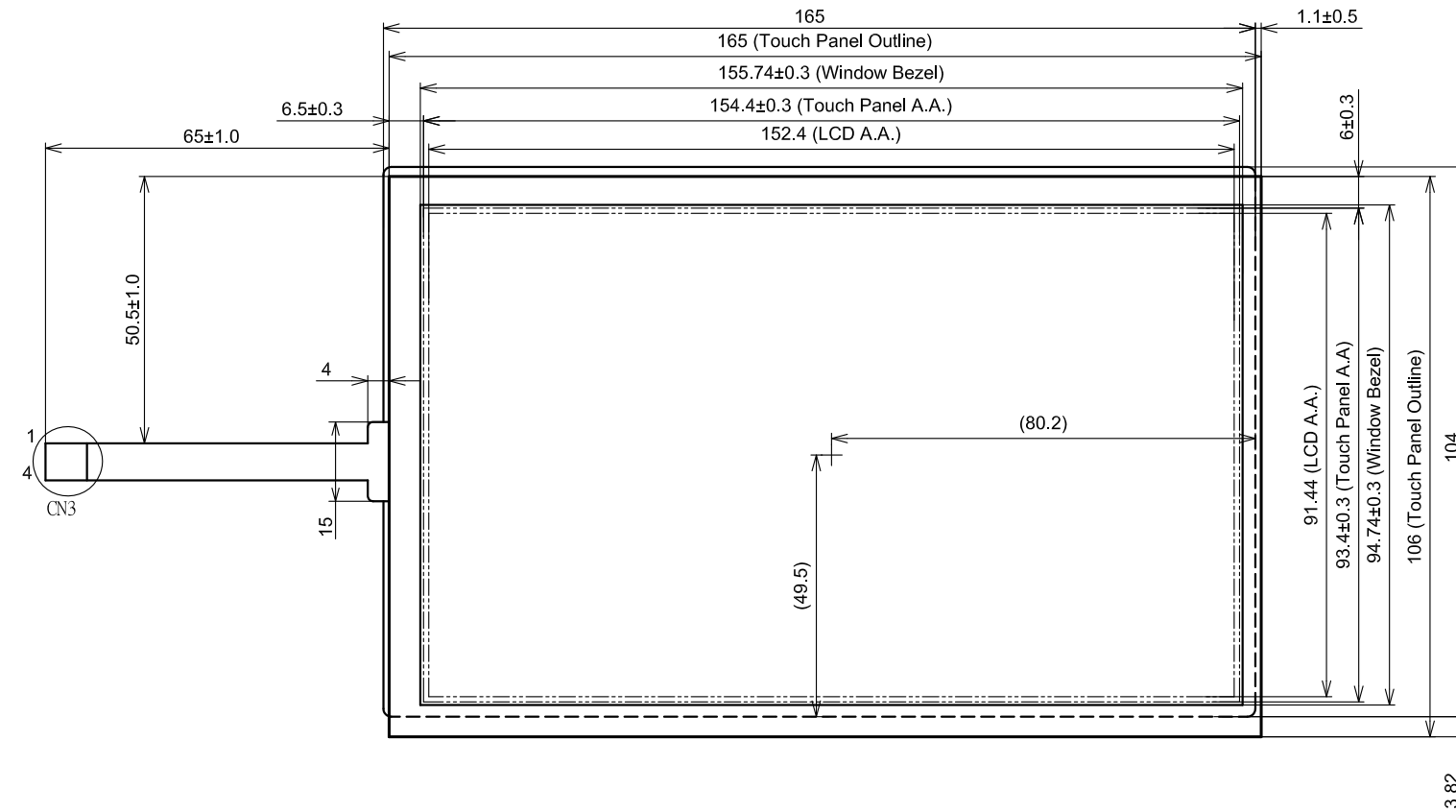

CN3 Interface Pin Connection

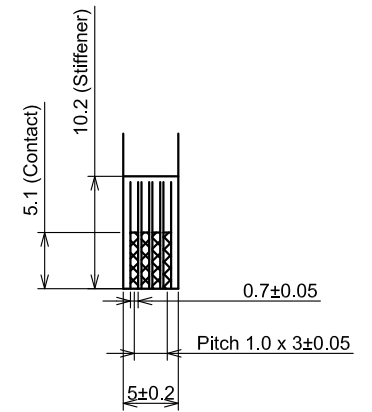

CN3 Detail

\*\* Undefined tolerance is ±0.5mm

Scale : NTS  
Unit : mm



# 10.2 REAR VIEW

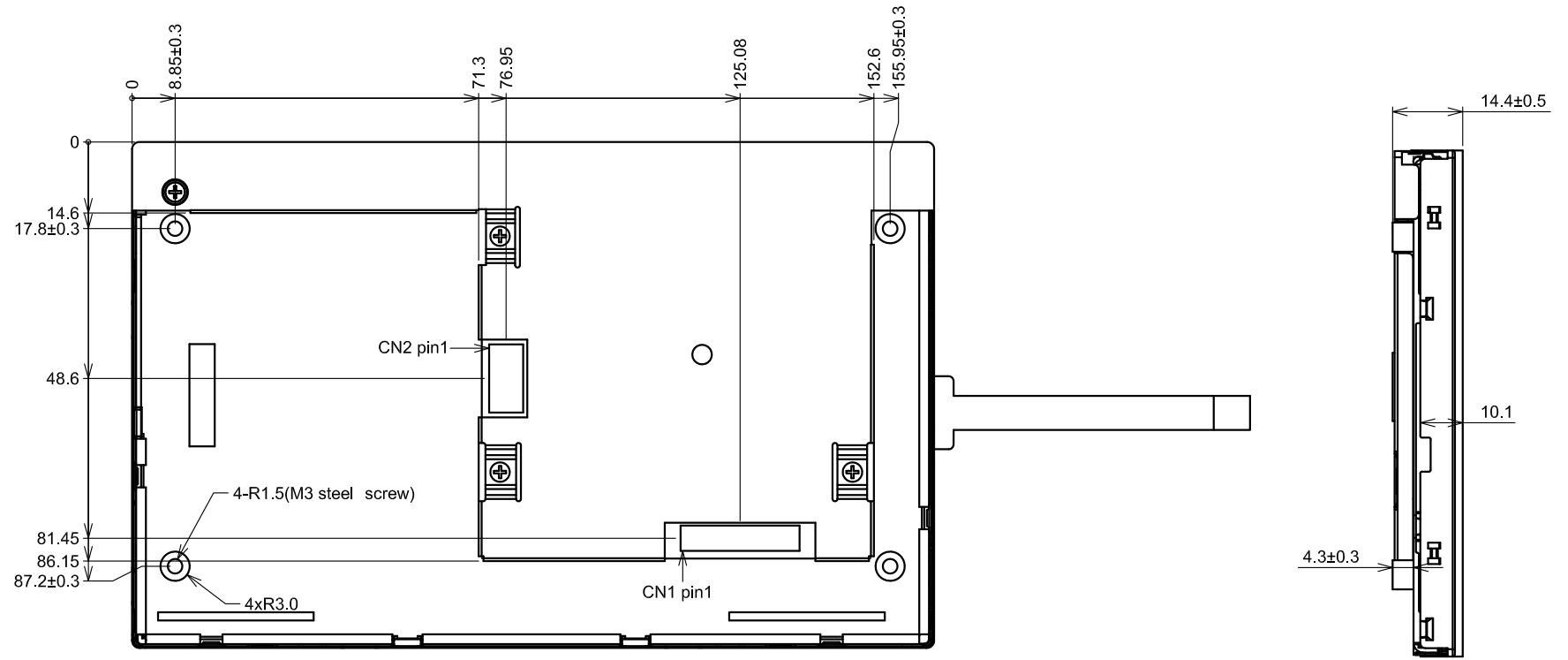

\*\* Undefined tolerance is ±0.5mm

Scale : NTS  
Unit : mm

# 11. TOUCH PANEL

The type of touch panel used on this display is resistive, analog, 4-wire and film on glass, and more characteristics are shown as below:

## 11.1 OPERATING CONDITIONS

Item	Specification	Remarks
Operating Voltage	5VDC	-

## 11.2 ELECTRICAL CHARACTERISTICS

Item	Specification	Remarks
Resistance Between Terminal	X1-X2	400~1200Ω
	Y1-Y2	160~660Ω
Insulation Resistance	X-Y	20MΩ min. At 25V DC
Linearity	X	±1.5% max.
	Y	±1.5% max.
Chattering	10ms max.	-

Note 1: The test conditions and equipments of linearity are as below:

- Material of pen: poly-acetal resin
- End shape: R 0.8 mm
- Test force: 150 gf
- Pitch: 10 mm
- Test area is shown in Fig. 11.1

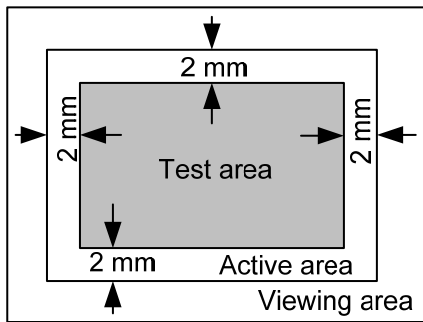

Fig. 11.1

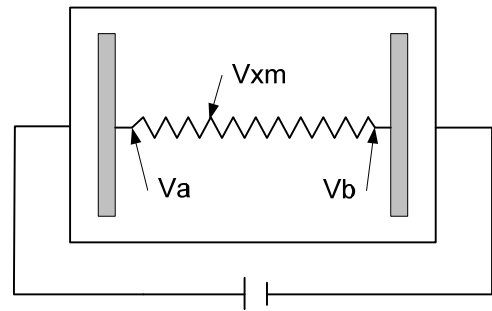

Fig. 11.2

As shown in Fig. 11.2, applying voltage meter to measure  $V_a$ ,  $V_b$  and  $V_{xm}$ , where  $V_a$  is the maximum voltage in the active area;  $V_b$  is the minimum voltage in the active area;  $V_{xm}$  is the measured voltage of point x selected by random. Afterwards, the linearity can be calculated by following equation:

$$Linearity = \frac{|V_{xi} - V_{xm}|}{V_a - V_b} \times 100\%$$

where  $V_{xi}$  is the idea voltage of point x.

The method to measure the linearity of Y-axis is the same as above.

### 11.3 MECHANICAL CHARACTERISTICS

Item	Specification	Remarks
Pen Input Pressure	50 ~ 150 g	R0.8, Polyacetal Pen
Finger	50 ~ 150 g	R8.0, Silicon Rubber
Surface Hardness	3H min.	JIS K 5400

### 11.4 OPTICAL CHARACTERISTICS

Item	Specification	Remarks
Transmittance	77% min.	-

### 11.5 SAFETY AND ATTENTIONS

- 1) Do not put heavy shock or stress on the touch panel.
- 2) Please use soft cloth or absorbent cotton with ethanol to clean the touch panel by gently wiping. Moreover, please wipe it by horizontal or vertical direction instead of circling to prevent leaving scars on the touch panel's surface.
- 3) Do not use any harmful chemicals such as acetone, toluene, and isopropyl alcohol to clean the display's surface.
- 4) Please pay more attention on handling and assembly due to that the touch panel size is larger than this TFT display.
- 5) Please ensure housing design is able to protect touch panel when unexpected pressure adding on the edges and corners of it.
- 6) UV protection is recommended to avoid the possibility of performance degrading when touch panel is likely applied under UV environment for a long period of time.

## 12. APPEARANCE STANDARD

The appearance inspection is performed in a dark room around 500~1000 lx based on the conditions as below:

- The distance between inspector's eyes and display is 30 cm.
- The viewing zone is defined with angle  $\theta$  shown in Fig. 12.1 The inspection should be performed within  $45^\circ$  when display is shut down. The inspection should be performed within  $5^\circ$  when display is power on.

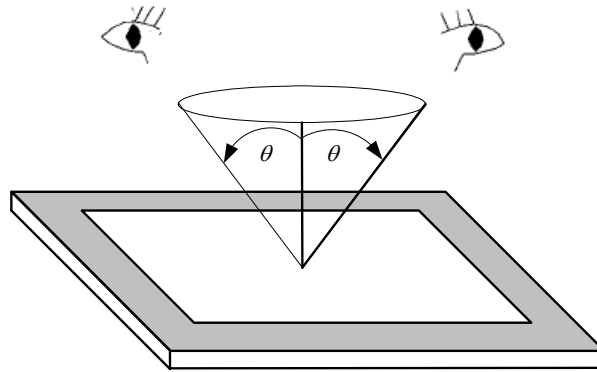

Fig 12.1

### 12.1 THE DEFINITION OF LCD ZONE

LCD panel is divided into 3 areas as shown in Fig.12.2 for appearance specification in next section. A zone is the LCD active area (dot area); B zone is the area, which extended 1 mm out from LCD active area; C zone is the area between B zone and metal frame.

In terms of housing design, B zone is the recommended window area customers' housing should be located in.

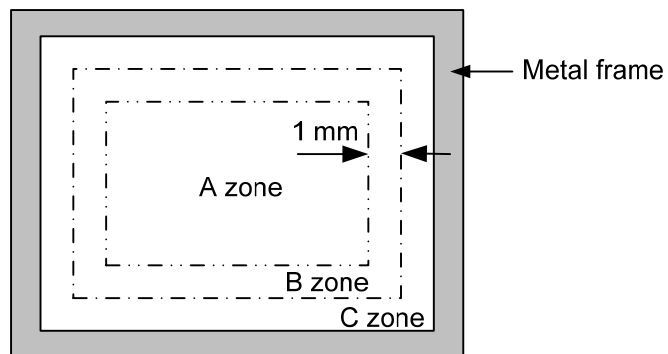

Fig 12.2

## 12.2 LCD APPEARANCE SPECIFICATION

The specification as below is defined as the amount of unexpected phenomenon or material in different zones of LCD panel. The definitions of length, width and average diameter using in the table are shown in Fig. 12.3 and Fig. 12.4.

Item	Criteria				Applied zone
Scratches	Length (mm)	Width (mm)	Maximum number	Minimum space	A
	Ignored	$W \leq 0.01$	Ignored	-	
	$L \leq 40$	$W \leq 0.02$	10	-	
	$L \leq 20$	$W \leq 0.04$	10	-	
	Round (Dot Shape)				
	Average diameter (mm)	Maximum number	Minimum space		
	$D \leq 0.2$	Ignore	-		
	$D \leq 0.4$	10	-		
Dent	Serious one is not allowed				A
Wrinkles in polarizer	Serious one is not allowed				A
Bubbles on polarizer	Average diameter (mm)		Maximum number		A
	$D \leq 0.3$		Ignored		
	$D \leq 0.5$		10		
	$D \leq 1.0$		5		
1) Stains 2) Foreign Materials 3) Dark Spot	Filamentous (Line shape)				A
	Length (mm)	Width (mm)	Maximum number		
	Ignored	$W \leq 0.02$	Ignored		
	$L \leq 2.0$	$W \leq 0.03$	10		
	$L \leq 1.0$	$W \leq 0.06$	10		
	Round (Dot shape)				A
	Average diameter (mm)	Maximum number	Minimum Space		
	$D \leq 0.22$	Ignored	-		
	$D \leq 0.33$	5	-		
	$D > 0.33$	0	-		
	In total	Filamentous + Round=10			
	Those wiped out easily are acceptable				
Dot-Defect (Note 1)	Bright dot-defect	Type	Maximum number		A
		1 dot	4		
		2 adjacent dot	1		
		3 adjacent dot or above	Not allowed		
		Density	$2(\phi 20\text{mm})$		
	In total	5			
	Dark dot-defect	1 dot	5		
		2 adjacent dot	2		
		3 adjacent dot or above	Not allowed		
		Density	$3(\phi 20\text{mm})$		
		In total	5		
In total		10			

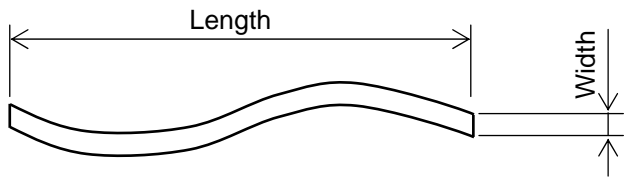
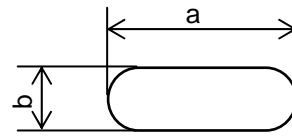

Fig 12.3



$$\text{Average diameter} = \frac{a+b}{2}$$

Fig 12.4

Note 1: The definitions of dot defect are as below:

- The defect area of the dot must be bigger than half of a dot.
- For bright dot-defect, showing black pattern, the dot's brightness must be over 30% brighter than others.
- For dark dot-defect, showing white pattern, the dot's brightness must be under 70% darker than others.
- The definition of 1-dot-defect is the defect-dot, which is isolated and no adjacent defect-dot.
- The definition of adjacent dot is shown as Fig. 12.5.
- The Density of dot defect is defined in the area within diameter  $\phi = 20\text{mm}$ .

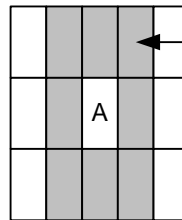

The dots colored gray are adjacent to defect-dot A.

Fig 12.5

### 12.3 TOUCH PANEL APPEARANCE SPECIFICATION

The specification as below is defined by the amount of unexpected material in different zones of touch panel.

Item	Criteria			Applied zone
Scratches	Width (mm)	Length (mm)	Maximum number	A
	$W \geq 0.10$	$L \geq 10$	Not allowed	
	$0.10 > W \geq 0.05$	$L < 10$	4 pcs max.	
	$0.05 < W$	$L < 10$	Ignored	
Foreign Materials	Filamentous (Line shape)			A
	Width (mm)	Length (mm)	Maximum number	
	$W > 0.05$	$L > 3$	Not allowed	
	$0.05 \geq W$	$L \leq 3$	Ignored	
	Round (Dot shape)			A
	Average diameter (mm)		Maximum number	
	$D > 0.3$		Not allowed	
	$0.3 \geq D > 0.2$		3 pcs max.	
	$0.2 \geq D > 0.1$		5 pcs max.	
	$0.1 \geq D$		Ignored	
$D \leq 0.5$		Ignored	B	

The limitation of glass flaw occurred on touch panel is defined in the table as below.

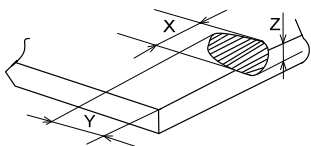
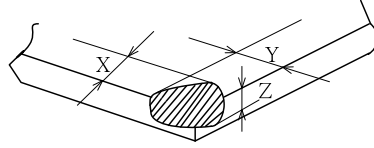
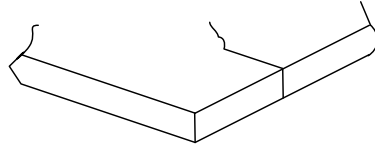
Item	Specifications	
Edge flaw		$X \leq 3.0 \text{ mm}$ $Y \leq 3.0 \text{ mm}$ $Z \leq \text{Thickness}$
Corner flaw		$X \leq 3.0 \text{ mm}$ $Y \leq 3.0 \text{ mm}$ $Z \leq \text{Thickness}$
Progressive flaw		Not allowed

## 13. PRECAUTIONS

### 13.1 PRECAUTIONS of MOUNTING

1) Please refer to Fig. 13.1 for housing the display with touch panel into applications. The Fig. 13.1 shows some points as below:

- The cushion needs to be designed between housing and touch panel in order to avoid unexpected pressure to cause any wrong reactions, and the cushion should be located in the insulated area.
- The housing should not cover the active area of touch panel as the figure shown.

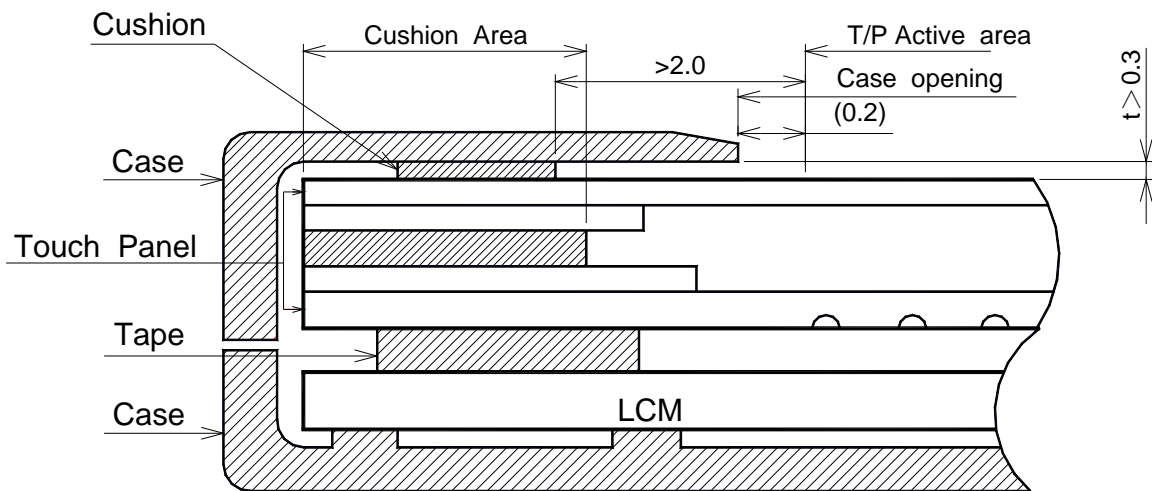

Fig 13.1

### 13.2 PRECAUTIONS OF ESD

- 1) Before handling the display, please ensure your body has been connected to ground to avoid any damages by ESD. Also, do not touch display's interface directly when assembling.
- 2) Please remove the protection film very slowly before turning on the display to avoid generating ESD.

### 13.3 PRECAUTIONS OF HANDLING

- 1) In order to keep the appearance of display in good condition, please do not rub any surfaces of the displays by sharp tools harder than 3H, especially touch panel, metal frame and polarizer.
- 2) Please do not pile the displays in order to avoid any scars leaving on the display. In order to avoid any injuries, please pay more attention for the edges of glasses and metal frame, and wear finger cots to protect yourself and the display before working on it.
- 3) Touching the display area or the terminal pins with bare hand is prohibited. This is because it will stain the display area and cause poor insulation between terminal pins, and might affect display's electrical characteristics furthermore.
- 4) Do not use any harmful chemicals such as acetone, toluene, and isopropyl alcohol to clean display's surfaces.
- 5) Please use soft cloth or absorbent cotton with ethanol to clean the display by gently wiping. Moreover, when wiping the display, please wipe it by horizontal or vertical direction instead of circling to prevent leaving scars on the display's surface, especially polarizer.



- 6) Please wipe any unknown liquids immediately such as saliva, water or dew on the display to avoid color fading or any permanently damages.
- 7) Maximum pressure to the surface of the display must be less than  $1,96 \times 10^4$  Pa. If the area of adding pressure is less than  $1 \text{ cm}^2$ , the maximum pressure must be less than 1.96N.

### 13.4 PRECAUTIONS OF OPERATING

- 1) Please input signals and voltages to the displays according to the values defined in the section of electrical characteristics to obtain the best performance. Any voltages over than absolute maximum rating will cause permanent damages to this display. Also, any timing of the signals out of this specification would cause unexpected performance.
- 2) When the display is operating at significant low temperature, the response time will be slower than it at  $25\text{C}^\circ$ . In high temperature, the color will be slightly dark and blue compared to original pattern. However, these are temperature-related phenomenon of LCD and it will not cause permanent damages to the display when used within the operating temperature.
- 3) The use of screen saver or sleep mode is recommended when static images are likely for long periods of time. This is to avoid the possibility of image sticking.
- 4) Spike noise can cause malfunction of the circuit. The recommended limitation of spike noise is no bigger than  $\pm 100 \text{ mV}$ .

### 13.5 PRECAUTIONS of STORAGE

If the displays are going to be stored for years, please be aware the following notices.

- 1) Please store the displays in a dark room to avoid any damages from sunlight and other sources of UV light.
- 2) The recommended long term storage temperature is between  $10\text{C}^\circ \sim 35\text{C}^\circ$  and 55%~75% humidity to avoid causing bubbles between polarizer and LCD glasses, and polarizer peeling from LCD glasses.
- 3) It would be better to keep the displays in the container, which is shipped from Hitachi, and do not unpack it.
- 4) Please do not stick any labels on the display surface for a long time, especially on the polarizer.

# 14. DESIGNATION OF LOT MARK

1) The lot mark is showing in Fig.13.3. First 4 digits are used to represent production lot, T represented made in Taiwan, and the last 5 digits are the serial number.

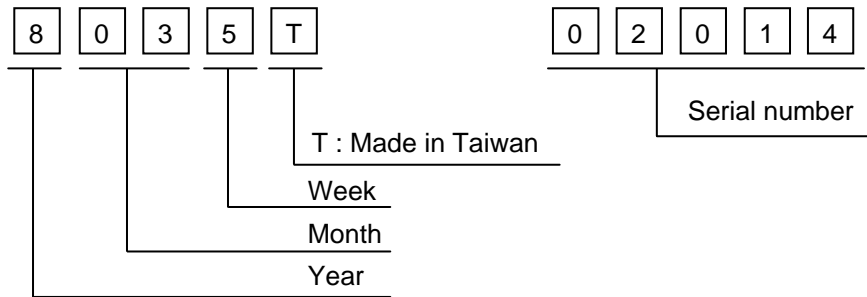

2) The tables as below are showing what the first 4 digits of lot mark are shorted for.

Year	Mark
2012	2
2013	3
2014	4
2015	5
2016	6

Month	Mark	Month	Mark
1	01	7	07
2	02	8	08
3	03	9	09
4	04	10	10
5	05	11	11
6	06	12	12

Week (Days)	Mark
1~7	1
8~14	2
15~21	3
22~28	4
29~31	5

3) Except letters I and O, revision number will be shown on lot mark and following letters A to Z.

4) The location of the lot mark is on the back of the display shown in Fig. 14.3.



Fig 14.3