

KOE

JDI Group

Kaohsiung Opto-Electronics Inc.

FOR MESSRS : _____

DATE : May 30th ,2013

CUSTOMER'S ACCEPTANCE SPECIFICATIONS

TX18D37VM0AQA

Contents

No.	ITEM	SHEET No.	PAGE
1	COVER	7B64PS 2701-TX18D37VM0AQA-1	1-1/1
2	RECORD OF REVISION	7B64PS 2702-TX18D37VM0AQA-1	2-1/2~2/2
3	GENERAL DATA	7B64PS 2703-TX18D37VM0AQA-1	3-1/1
4	ABSOLUTE MAXIMUM RATINGS	7B64PS 2704-TX18D37VM0AQA-1	4-1/1
5	ELECTRICAL CHARACTERISTICS	7B64PS 2705-TX18D37VM0AQA-1	5-1/1
6	OPTICAL CHARACTERISTICS	7B64PS 2706-TX18D37VM0AQA-1	6-1/2~2/2
7	BLOCK DIAGRAM	7B64PS 2707-TX18D37VM0AQA-1	7-1/1
8	RELIABILITY TESTS	7B64PS 2708-TX18D37VM0AQA-1	8-1/1
9	LCD INTERFACE	7B64PS 2709-TX18D37VM0AQA-1	9-1/7~7/7
10	OUTLINE DIMENSIONS	7B64PS 2710-TX18D37VM0AQA-1	10-1/2~2/2
11	TOUCH PANEL	7B64PS 2711-TX18D37VM0AQA-1	11-1/2~2/2
12	APPEARANCE STANDARD	7B64PS 2712-TX18D37VM0AQA-1	12-1/4~4/4
13	PRECAUTIONS	7B64PS 2713-TX18D37VM0AQA-1	13-1/2~2/2
14	DESIGNATION OF LOT MARK	7B64PS 2714-TX18D37VM0AQA-1	14-1/1

ACCEPTED BY: _____

PROPOSED BY: Jim Fang

2. RECORD OF REVISION

2.1 RECORD OF CONTENT REVISION

DATE	SHEET No.	SUMMARY

2.2 RECORD OF FIRMWARE REVISION

FIRMWARE REVISION	SUMMARY
V0.1.0	Initial release

3. GENERAL DATA

3.1 DISPLAY FEATURES

This module is a 7”(for Touch Panel) WVGA of 16:9 format amorphous silicon TFT. The pixel format is vertical stripe and sub pixels are arranged as R (red), G (green), B (blue) sequentially. This display is RoHS compliant, COG (chip on glass) technology and LED backlight are applied on this display.

Part Name	TX18D37VM0AQA
Module Dimensions	178.76(W) mm x 115.0(H) mm x 15.12 (D) mm typ.
LCD Active Area	152.4(W) mm x 91.44(H) mm
Pixel Pitch	0.1905(W) mm x 0.1905 (H) mm
Resolution	800 x 3(RGB)(W) x 480(H) dots
Color Pixel Arrangement	R, G, B Vertical stripe
LCD Type	Transmissive Color TFT; Normally Black
Display Type	Active Matrix
Number of Colors	262k Colors
Backlight	12 LEDs (3 series x 4)
Weight	320g typ.
Interface	LVDS 20 pins for LCD; USB for Touch Panel
Power Supply Voltage	3.3V for LCD; 12V for Backlight; 5.0V / 3.3V for Touch Panel
Power Consumption	1.55W for LCD; 4.56W for Backlight
Viewing Direction	Super Wide Version (In-Plane Switching)
Touch Panel	Capacitive type; Cover Glass on ITO film; 2 Point Touch Available

4. ABSOLUTE MAXIMUM RATINGS

Item	Symbol	Min.	Max.	Unit	Remarks
Supply Voltage	V_{DD}	-0.3	3.6	V	-
Input Voltage of Logic	V_I	-0.3	$V_{DD}+0.3$	V	Note 1
Operating Temperature	T_{op}	-30	80	°C	Note 2
Storage Temperature	T_{st}	-40	90	°C	Note 2
Backlight Input Voltage	V_{LED}	-	15	V	-

Note 1: The rating is defined for the signal voltages of the interface such as CLK and pixel data pairs.

Note 2: The maximum rating is defined as above based on the chamber temperature, which might be different from ambient temperature after assembling the panel into the application. Moreover, some temperature-related phenomenon as below needed to be noticed:

- Background color, contrast and response time would be different in temperatures other than 25°C.

Operating under high temperature will shorten LED lifetime.

5. ELECTRICAL CHARACTERISTICS

5.1 LCD CHARACTERISTICS

$T_a = 25\text{ }^\circ\text{C}$, $V_{SS} = 0\text{V}$

Item	Symbol	Condition	Min.	Typ.	Max.	Unit	Remarks
Power Supply Voltage	V_{DD}	-	3.0	3.3	3.6	V	-
Differential Input Voltage for LVDS Receiver Threshold	V_I	"H" level	-	-	+100	mV	Note 1
		"L" level	-100	-	-		
Power Supply Current	I_{DD}	$V_{DD}=3.3\text{V}$	-	470	500	mA	Note 2
Vsync Frequency	f_v	-	-	60	75	Hz	-
Hsync Frequency	f_H	-	29	31.5	33	KHz	Note 3
CLK Frequency	f_{CLK}	-	30.0	33.3	36.0	MHz	

Note 1: $V_{CM}=+1.2\text{V}$

V_{CM} is common mode voltage of LVDS transmitter/receiver.

The input terminal of LVDS transmitter is terminated with 100Ω .

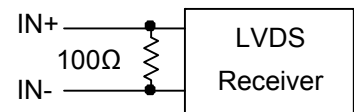

Note 2: An all white check pattern is used when measuring I_{DD} . f_v is set to 60 Hz.

Note 3: For LVDS transmitter input.

Note 4: 1.0A fuse is applied in the module for I_{DD} . For display activation and protection purpose, power supply is recommended larger than 2.5A to start the display and break fuse once any short circuit occurred.

5.2 BACKLIGHT CHARACTERISTICS

$T_a = 25\text{ }^\circ\text{C}$

Item	Symbol	Condition	Min.	Typ.	Max.	Unit	Remarks
LED Input Voltage	V_{LED}	-	11.7	12	12.3	V	Note1
LED Forward Current (Dim Control)	I_{LED}	0V; 0% duty	370	380	390	mA	Note 2
		3.3VDC; 100% duty	24	30	36		
LED lifetime	-	$I_{LED}=380\text{ mA}$	-	70K	-	hrs	Note 3

Note 1: As Fig. 5.1 shown, LED current is constant, 380 mA, controlled by the LED driver when applying 12V V_{LED} .

Note 2: Dimming function can be obtained by applying DC voltage or PWM signal from the display interface CN1. The recommended PWM signal is 1K ~ 10K Hz with 3.3V amplitude.

Note 3: The estimated lifetime is specified as the time to reduce 50% brightness by applying 380 mA at $25\text{ }^\circ\text{C}$.

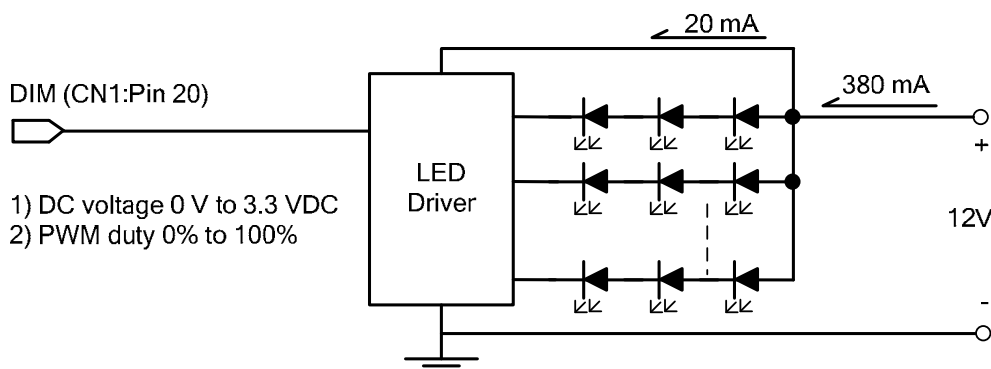

Fig 5.1

6. OPTICAL CHARACTERISTICS

The optical characteristics are measured based on the conditions as below:

- Supplying the signals and voltages defined in the section of electrical characteristics.
- The backlight unit needs to be turned on for 30 minutes.
- The ambient temperature is 25°C.
- In the dark room around 500~1000 lx, the equipment has been set for the measurements as shown in Fig 6.1.

$$T_a = 25^\circ\text{C}, f_v = 60\text{Hz}, V_{DD} = 3.3\text{V}$$

Item	Symbol	Condition	Min.	Typ.	Max.	Unit	Remarks
Brightness of White	-	$\phi = 0^\circ, \theta = 0^\circ,$ $I_{LED} = 380\text{mA}$	280	380	-	cd/m ²	Note 1
Brightness Uniformity	-		70	-	-	%	Note 2
Contrast Ratio	CR		-	600	-	-	Note 3
Response Time (Rising + Falling)	$T_r + T_f$	$\phi = 0^\circ, \theta = 0^\circ$	-	-	45	ms	Note 4
Viewing Angle	θ_x	$\phi = 0^\circ, CR \geq 10$	-	85	-	Degree	Note 5
	$\theta_{x'}$	$\phi = 180^\circ, CR \geq 10$	-	85	-		
	θ_y	$\phi = 90^\circ, CR \geq 10$	-	85	-		
	$\theta_{y'}$	$\phi = 270^\circ, CR \geq 10$	-	85	-		
Color Chromaticity	Red	X	(0.55)	0.60	(0.65)	-	Note 6
		Y	(0.31)	0.36	(0.41)		
	Green	X	(0.31)	0.36	(0.41)		
		Y	(0.54)	0.59	(0.64)		
	Blue	X	(0.10)	0.15	(0.20)		
		Y	(0.07)	0.12	(0.17)		
	White	X	(0.27)	0.32	(0.37)		
		Y	(0.29)	0.34	(0.39)		

Note 1: The brightness is measured from the panel center point, P5 in Fig. 6.2, for the typical value.

Note 2: The brightness uniformity is calculated by the equation as below:

$$\text{Brightness uniformity} = \frac{\text{Min. Brightness}}{\text{Max. Brightness}} \times 100\%$$

, which is based on the brightness values of the 9 points measured by BM-5 as shown in Fig. 6.2.

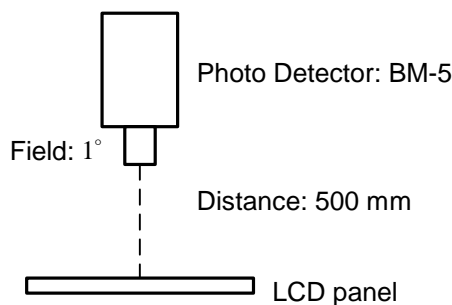

Fig. 6.1

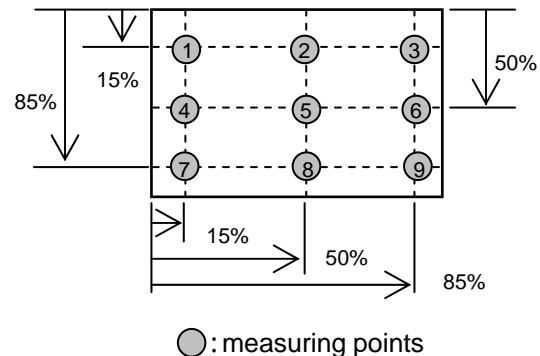

Fig. 6.2

Note 3: The Contrast Ratio is measured from the center point of the panel, P5, and defined as the following equation:

$$CR = \frac{\text{Brightness of White}}{\text{Brightness of Black}}$$

Note 4: The definition of response time is shown in Fig. 6.3. The rising time is the period from 10% brightness to 90% brightness when the data is from black to white. Oppositely, Falling time is the period from 90% brightness falling to 10% brightness.

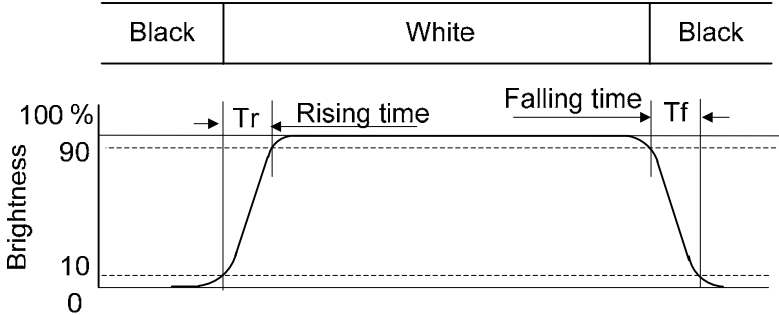

Fig 6.3

Note 5: The definition of viewing angle is shown in Fig. 6.4. Angle ϕ is used to represent viewing directions, for instance, $\phi = 270^\circ$ means 6 o'clock, and $\phi = 0^\circ$ means 3 o'clock. Moreover, angle θ is used to represent viewing angles from axis Z toward plane XY.

The display is super wide viewing angle version, so that the best optical performance can be obtained from every viewing direction.

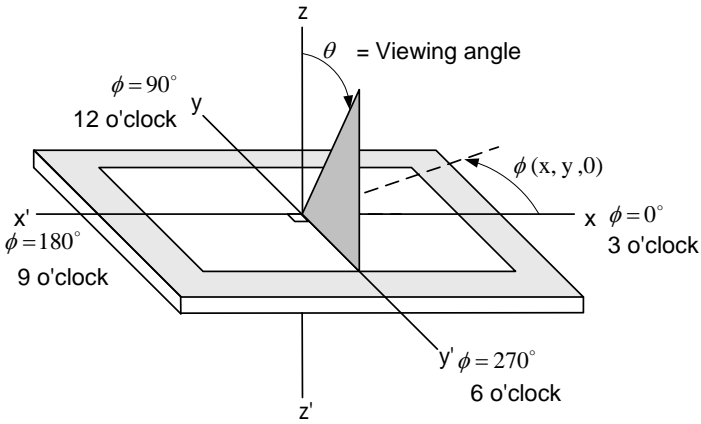
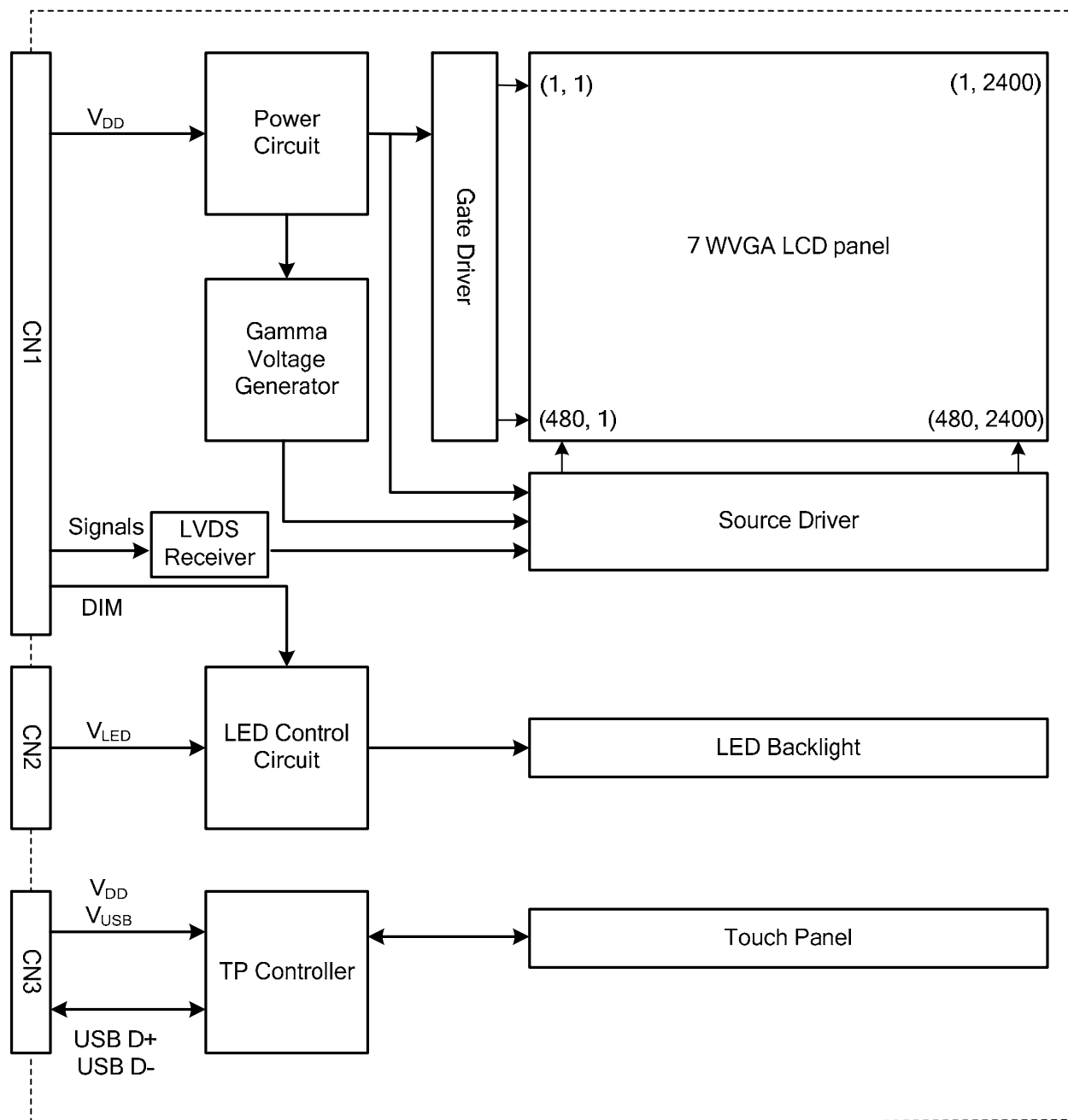

Fig 6.4

Note 6: The color chromaticity is measured from the center point of the panel, P5, as shown in Fig. 6.2.

7. BLOCK DIAGRAM



Note 1: Signals are CLK and pixel data pairs.

8. RELIABILITY TESTS

Test Item	Condition	
High Temperature	1) Operating 2) 80 °C	500 hrs
Low Temperature	1) Operating 2) -30 °C	500 hrs
High Temperature	1) Storage 2) 90 °C	500 hrs
Low Temperature	1) Storage 2) -40 °C	500 hrs
Heat Cycle	1) Operating 2) -30 °C ↔ 80 °C 3) 3hrs~1hr~3hrs	500 hrs
Thermal Shock	1) Non-Operating 2) -35 °C ↔ 85 °C 3) 0.5 hr ↔ 0.5 hr	500 hrs
High Temperature & Humidity	1) Operating 2) 40 °C & 85%RH 3) Without condensation (Note4)	500 hrs
Vibration	1) Non-Operating 2) 10 ~ 200 Hz 3) 5G 4) X, Y, and Z directions	1 hr for each direction
Mechanical Shock	1) Non-Operating 2) 10 ms 3) 80G 4) ±X, ±Y and ±Z directions	Once for each direction
ESD	1) Operating 2) Tip: 150 pF, 330 Ω 3) Air discharge for glass: ± 12KV 4) Contact discharge for metal frame: ± 15KV	1) Glass: 9 points 2) Metal frame: 8 points (Note 3)

Note 1: Display functionalities are inspected under the conditions defined in the specification after the reliability tests.

Note 2: The display is not guaranteed for use in corrosive gas environments.

Note 3: All pins of LCD interface(CN1) have been tested by ± 100V contact discharge of ESD under non-operating condition.

Note 4: Under the condition of high temperature & humidity, if the temperature is higher than 40°C, the humidity needs to be reduced as Fig. 8.1 shown.

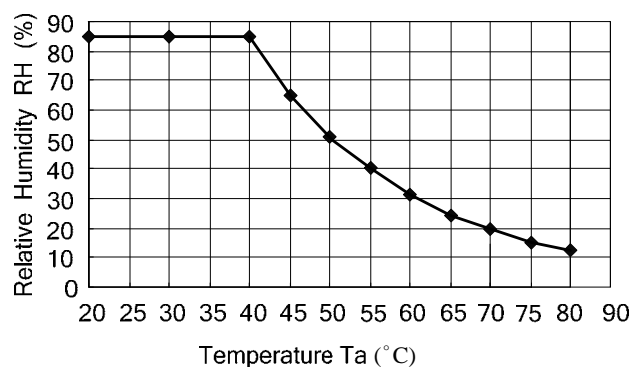

Fig. 8.1

9. LCD INTERFACE

9.1 INTERFACE PIN CONNECTIONS

The display interface connector (CN1) is FI-SEB20P-HF13E made by JAE and Pin assignment is as below:

Pin No.	Symbol	Signal	Pin No.	Symbol	Signal
1	V _{DD}	Power Supply for Logic	11	IN2-	B2~B5, DE
2	V _{DD}		12	IN2+	
3	V _{SS}	GND	13	V _{SS}	GND
4	V _{SS}		14	CLK IN-	Pixel Clock
5	IN0-	R0~R5, G0	15	CLK IN+	
6	IN0+		16	V _{SS}	GND
7	V _{SS}	GND	17	IN3-	GND
8	IN1-	G1~G5, B0~B1	18	IN3+	GND
9	IN1+		19	V _{SS}	GND
10	V _{SS}	GND	20	DIM	Note 2

Note 1: IN n- and IN n+ (n=0, 1, 2), CLK IN- and CLK IN+ should be wired by twist-pairs or side-by-side FPC patterns, respectively.

Note 2: Normal brightness: 0V or 0% PWM duty; Brightness control: 0V to 3.3V DC or 0% to 100% PWM duty.

The backlight connector (CN2) is SM02(8.0)B-BHS-1-TB(LF)(SN), and pin assignment is as below:

Pin No.	Signal	Signal
1	V _{LED}	12VDC
2	GND	GND

The Capacitive Touch Panel interface connector (CN3) is BL114-20RL-TAGF manufactured by Suncagey (Thickness: 0.3±0.05mm; Pitch: 0.5mm).

Pin No.	Symbol	Function	Pin No.	Symbol	Function
1	GND	GND	11	V _{DD}	Power Supply for Touch Panel
2	GND	GND	12	V _{DD}	Power Supply for Touch Panel
3	GND	GND	13	NC	No connection
4	GND	GND	14	NC	No connection
5	USB D+	USB D+ data pin	15	NC	No connection
6	USB D-	USB D- data pin	16	NC	No connection
7	NC	No connection	17	NC	No connection
8	V _{USB}	Power Supply for USB Interface	18	GND	GND
9	V _{USB}	Power Supply for USB Interface	19	GND	GND
10	NC	No connection	20	GND	GND

9.2 LVDS INTERFACE

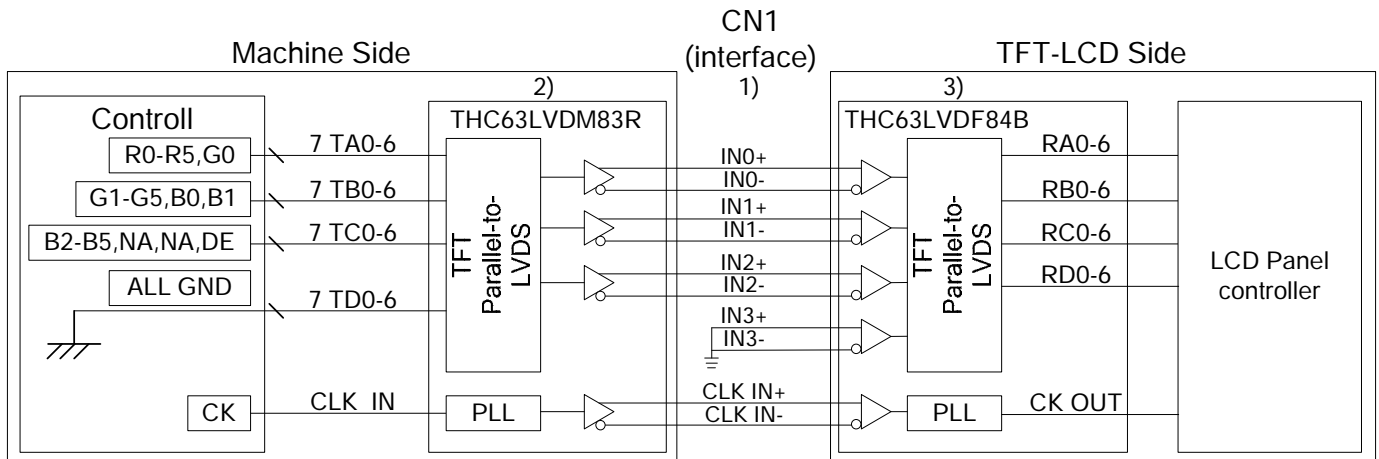

Note 1: LVDS cable impedance should be 100 ohms per signal line when each 2-lines (+, -) is used in differential mode.

Note 2: The recommended transmitter, THC63LVDM83R, is made by Thine or equivalent, which is not contained in the module.

Note 3: The receiver built-in the module is THC63LVDF84B made by Thine.

9.3 LVDS DATA FORMAT

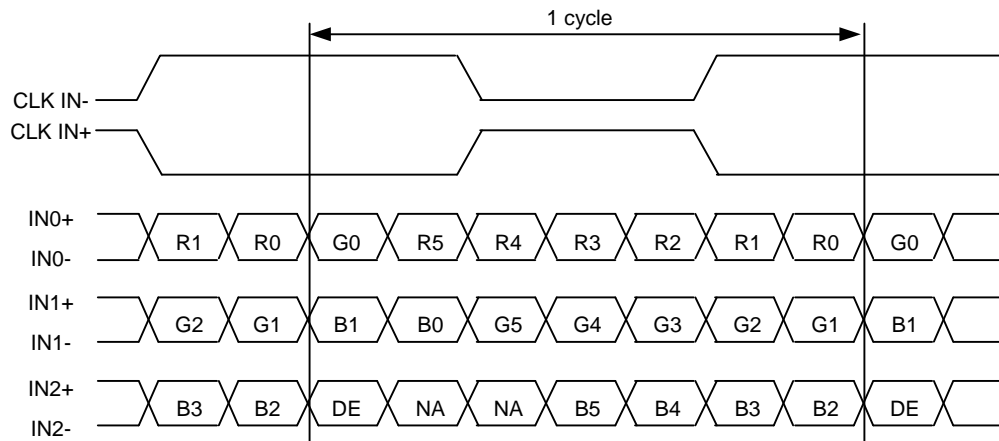

DE: Data Enable

NA: Not Available

9.4 TIMING CHART

DTMG (Data Enable) is the signal to determine valid data, and the timing of DTMG can be determined from Hsync and Vsync as below. For this display, only DTMG and DCLK are the essential signals. Hsync and Vsync are not necessary to connect to display interface after DTMG has been generated and input.

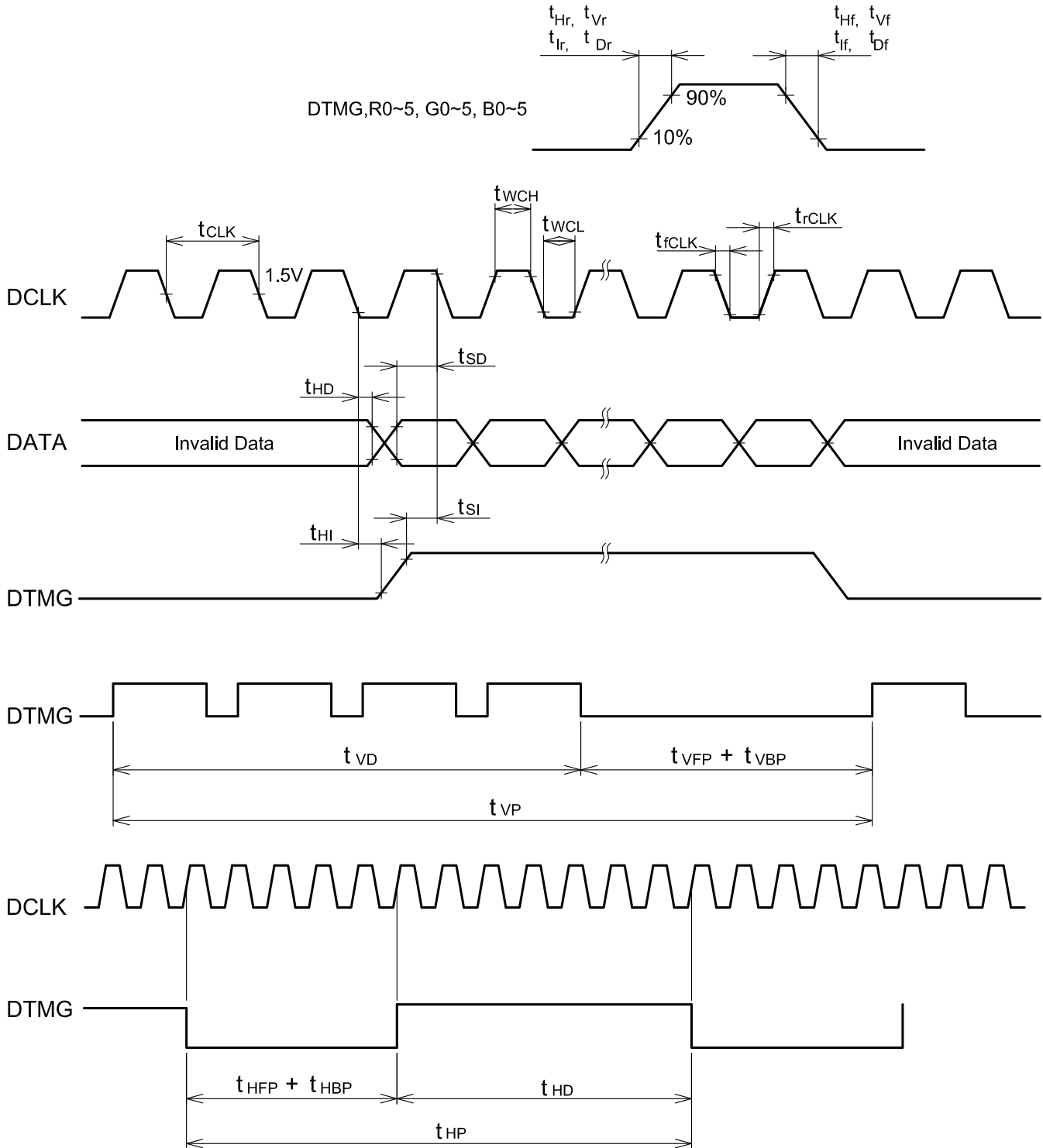

Data is latched by DCLK'S falling edge

9.5 INTERFACE TIMING SPECIFICATIONS

	Item	Symbol	Min.	Typ.	Max.	Unit
DCLK	Frequency	$1/t_{CLK}$	30.0	33.3	36.0	MHz
	Low level Width	t_{WCL}	8	-	-	ns
	High level Width	t_{WCH}	8	-	-	
	Rise time	t_{rCLK}	-	-	4	
	Fall time	t_{fCLK}	-	-	4	
	Duty	D	0.45	0.5	0.55	-
DTMG	Set up time	t_{SI}	4	-	-	ns
	Hold time	t_{HI}	4	-	-	
	Rise/Fall time	t_{r}, t_{f}	-	-	4	ns
	Horizontal cycle	t_{HP}	1035	1056	1090	t_{CLK}
	Horizontal back porch	t_{HBP}	10	216	-	
	Horizontal front porch	t_{HFP}	30	40	-	
	Vertical cycle	t_{VP}	483	525	550	t_{HP}
	Vertical back porch	t_{VBP}	2	34	-	
	Vertical front porch	t_{VFP}	1	11	-	
Data	Set up time	t_{SD}	4	-	-	ns
	Hold time	t_{HD}	4	-	-	
	Rise / Fall time	t_{Dr}, t_{Df}	-	-	4	ns

9.6 LVDS RECEIVER TIMING

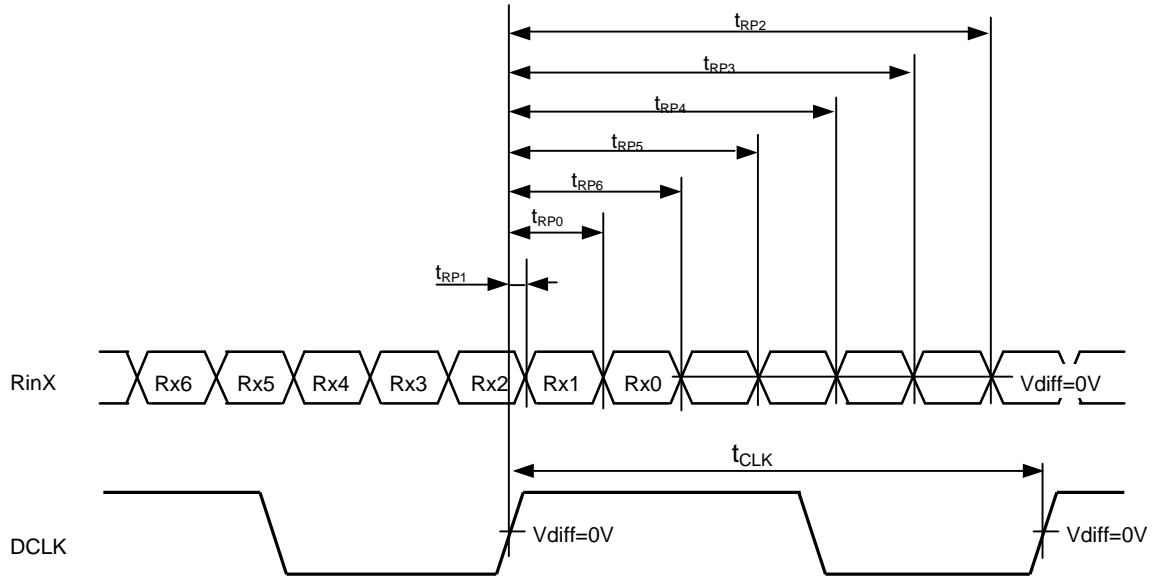

$$R_{inX} = (R_{inX+}) - (R_{inX-}) \quad (X=0, 1, 2)$$

Item	Symbol	Min.	Typ.	Max.	Unit	
DCLK	Frequency	$1/t_{CLK}$	30.0	33.3	36.0	MHz
R_{inX} ($X=0,1,2$)	0 data position	t_{RP0}	$1/7 * t_{CLK} - 0.4$	$1/7 * t_{CLK}$	$1/7 * t_{CLK} + 0.4$	ns
	1st data position	t_{RP1}	-0.4	0	+0.4	
	2nd data position	t_{RP2}	$6/7 * t_{CLK} - 0.4$	$6/7 * t_{CLK}$	$6/7 * t_{CLK} + 0.4$	
	3rd data position	t_{RP3}	$5/7 * t_{CLK} - 0.4$	$5/7 * t_{CLK}$	$5/7 * t_{CLK} + 0.4$	
	4th data position	t_{RP4}	$4/7 * t_{CLK} - 0.4$	$4/7 * t_{CLK}$	$4/7 * t_{CLK} + 0.4$	
	5th data position	t_{RP5}	$3/7 * t_{CLK} - 0.4$	$3/7 * t_{CLK}$	$3/7 * t_{CLK} + 0.4$	
	6th data position	t_{RP6}	$2/7 * t_{CLK} - 0.4$	$2/7 * t_{CLK}$	$2/7 * t_{CLK} + 0.4$	

9.7 DATA INPUT for DISPLAY COLOR

	COLOR & Gray Scale	Data Signal																	
		R5	R4	R3	R2	R1	R0	G5	G4	G3	G2	G1	G0	B5	B4	B3	B2	B1	B0
Basic Color	Black	0	0	0	0	0	0	0	0	0	0	0	0	0	0	0	0	0	0
	Red (63)	1	1	1	1	1	1	0	0	0	0	0	0	0	0	0	0	0	0
	Green (63)	0	0	0	0	0	0	1	1	1	1	1	1	0	0	0	0	0	0
	Blue (63)	0	0	0	0	0	0	0	0	0	0	0	0	1	1	1	1	1	1
	Cyan	0	0	0	0	0	0	1	1	1	1	1	1	1	1	1	1	1	1
	Magenta	1	1	1	1	1	1	0	0	0	0	0	0	1	1	1	1	1	1
	Yellow	1	1	1	1	1	1	1	1	1	1	1	1	0	0	0	0	0	0
	White	1	1	1	1	1	1	1	1	1	1	1	1	1	1	1	1	1	1
Red	Red (0)	0	0	0	0	0	0	0	0	0	0	0	0	0	0	0	0	0	0
	Red (1)	0	0	0	0	0	1	0	0	0	0	0	0	0	0	0	0	0	0
	:	:	:	:	:	:	:	:	:	:	:	:	:	:	:	:	:	:	:
	:	:	:	:	:	:	:	:	:	:	:	:	:	:	:	:	:	:	:
	Red (62)	1	1	1	1	1	0	0	0	0	0	0	0	0	0	0	0	0	0
	Red (63)	1	1	1	1	1	1	0	0	0	0	0	0	0	0	0	0	0	0
Green	Green (0)	0	0	0	0	0	0	0	0	0	0	0	0	0	0	0	0	0	0
	Green (1)	0	0	0	0	0	0	0	0	0	0	1	0	0	0	0	0	0	0
	:	:	:	:	:	:	:	:	:	:	:	:	:	:	:	:	:	:	:
	:	:	:	:	:	:	:	:	:	:	:	:	:	:	:	:	:	:	:
	Green (62)	0	0	0	0	0	0	1	1	1	1	1	0	0	0	0	0	0	0
	Green (63)	0	0	0	0	0	0	1	1	1	1	1	1	0	0	0	0	0	0
Blue	Blue (0)	0	0	0	0	0	0	0	0	0	0	0	0	0	0	0	0	0	0
	Blue (1)	0	0	0	0	0	0	0	0	0	0	0	0	0	0	0	0	0	1
	:	:	:	:	:	:	:	:	:	:	:	:	:	:	:	:	:	:	:
	:	:	:	:	:	:	:	:	:	:	:	:	:	:	:	:	:	:	:
	Blue (62)	0	0	0	0	0	0	0	0	0	0	0	0	1	1	1	1	1	0
	Blue (63)	0	0	0	0	0	0	0	0	0	0	0	0	1	1	1	1	1	1

9.8 POWER SEQUENCE

(1) LCD POWER SEQUENCE

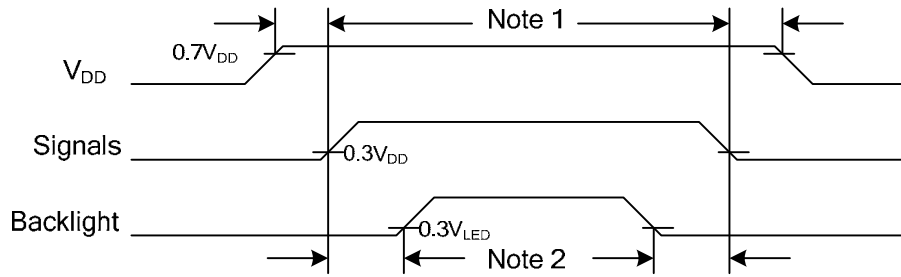
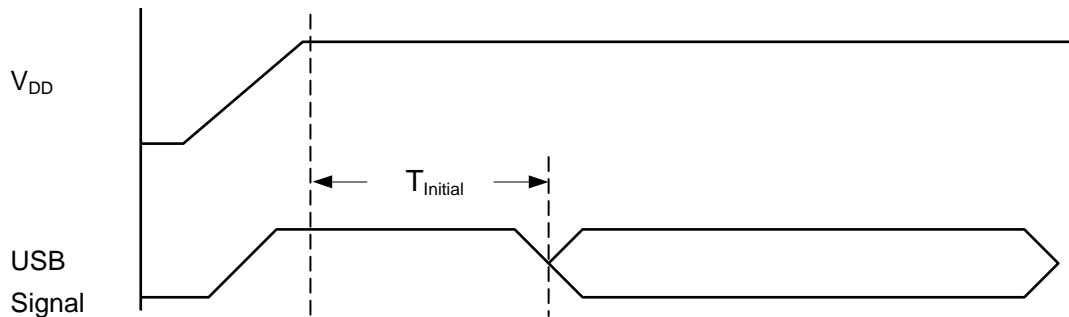

Fig. 9.1 Power Sequence Timing

Note 1: In order to avoid any damages, V_{DD} has to be applied before all other signals. The opposite is true for power off where V_{DD} has to be remained on until all other signals have been switch off. The recommended time period is 1 second.

Note 2: In order to avoid showing uncompleted patterns in transient state. It is recommended that switching the backlight on is delayed for 1 second after the signals have been applied. The opposite is true for power off where the backlight has to be switched off 1 second before the signals are removed.

(2) TOUCH PANEL POWER SEQUENCE AND RESET SEQUENCE



Symbol	Parameter	Min.	Max.	Unit
$T_{initial}$	After powering-on or resetting the device, the device needs $T_{initial}$ time config the system.	110	-	ms

10. OUTLINE DIMENSIONS

10.1 FRONT VIEW

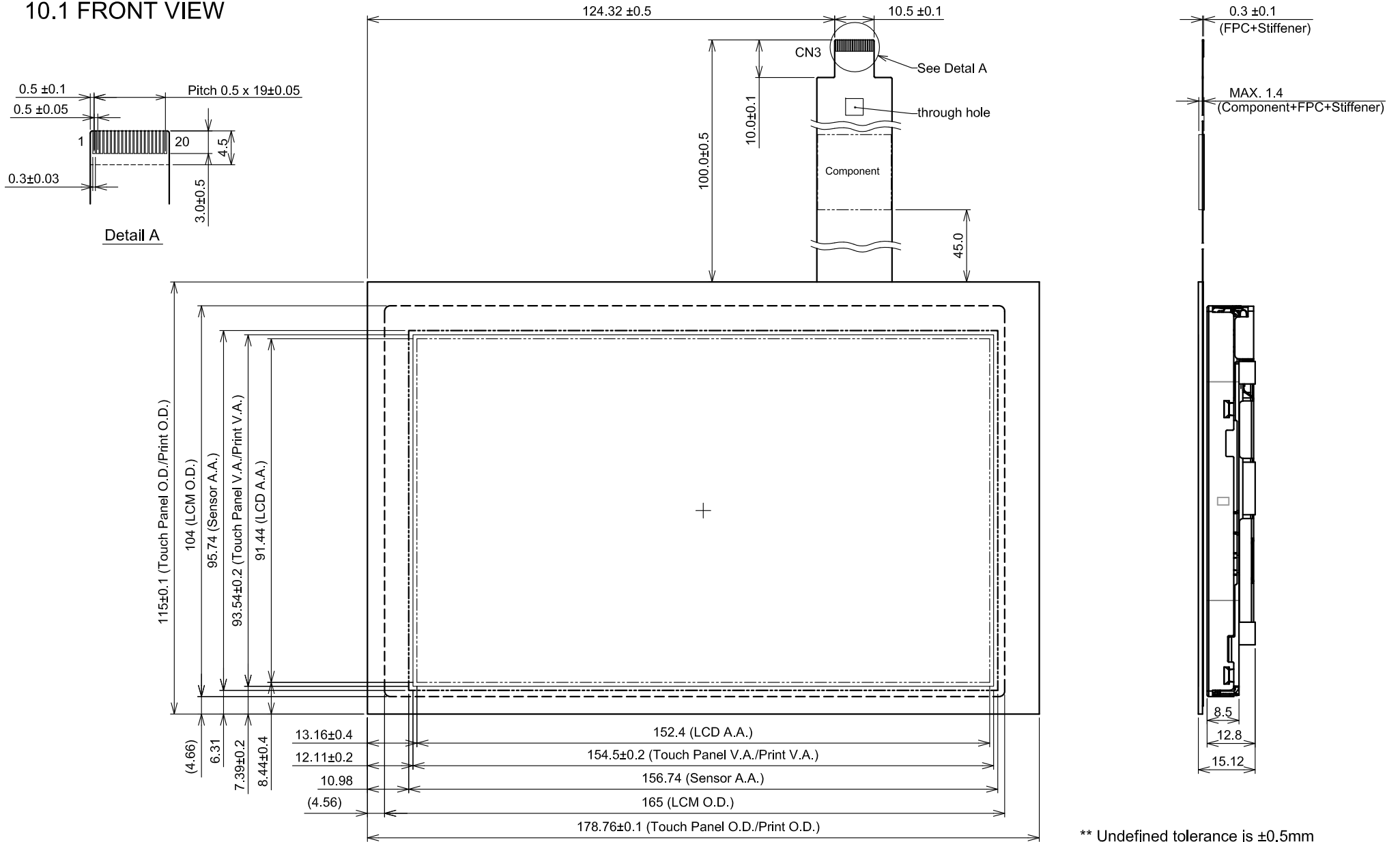

** Undefined tolerance is $\pm 0.5\text{mm}$

Scale : NTS
Unit : mm

10.2 REAR VIEW

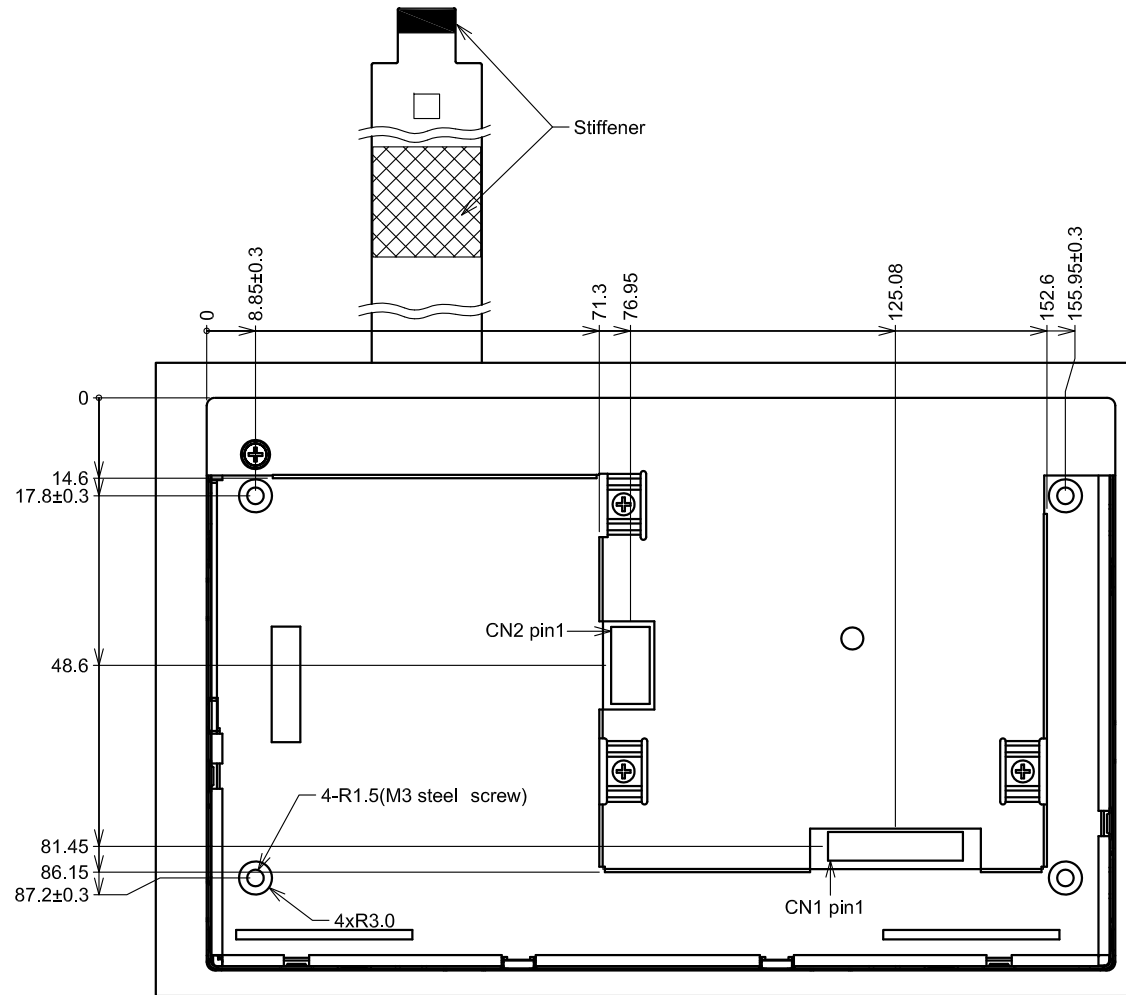

** Undefined tolerance is $\pm 0.5\text{mm}$

Scale : NTS
Unit : mm

11. TOUCH PANEL

The type of touch panel used on this display is capacitive touch panel film, and more characteristics are shown as below:

11.1 MECHANICAL CHARACTERISTICS

Item	Specification	Remarks
Cover Lens	t = 1.1mm	Soda-lime glass
Film Sensor	t = 0.22mm	-
Surface Hardness	>7H	-
Input Method	Finger	-
FPC Peeling Force	Min. 300g/cm	Peeling upward by 90°

11.2 ELECTRICAL CHARACTERISTICS

Item	Symbol	Symbol	Value			Unit	Remarks
			Min.	Typ.	Max.		
Power supply voltage	V _{DD}	V _{DD} -GND	2.8	3.3	3.6	V	-
Power supply voltage for USB	V _{USB}	V _{USB} -GND	4.5	5.0	5.5	V	-
Operation Current	I _{DD}	V _{DD} =3.3V GND=0V T _a =25°C	-	(25)	-	mA	-
Idle Mode Current	I _{Idld}		-	3	4	mA	-
Sleep Mode Current	I _{ST}		-	20	-	uA	-
Operating Frequency	1/t _{clcl}	-	0	-	40	MHz	-

11.3 CONTROLLER CHARACTERISTICS

The Capacitive Touch Panel features as below:

- Controller IC is ILITEK ILI2107u,
- Support USB 1.1 interface.

The data communication between the controller register and master CPU uses USB Interface, shown in Fig. 11.1

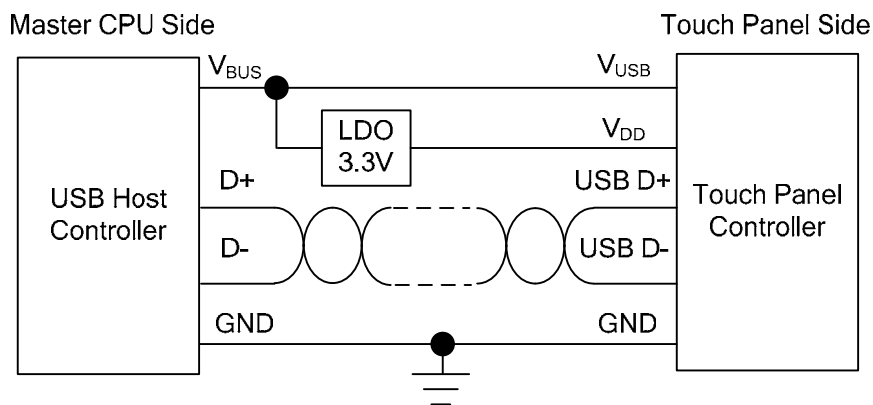

Fig. 11.1

The Touch Panel (for USB) Support Operating System as below:

System.	Single-point touch	Multi-point touch	Remark
Windows	<ul style="list-style-type: none"> - Windows XP(x86) - Windows 7(x86 / x64) (inside Driver) - Windows CE 5.0 - Windows CE 6.0 R1 - Windows CE 6.0 R2 - Windows CE 6.0 R3 - Embedded Windows XP(x86) - Embedded Windows 7(x86 / x64) (inside Driver) 	Windows 7(x86 / x64) (inside Driver)	-
Android (Kernel 2.6.32 upwards)	<ul style="list-style-type: none"> - Android 2.0 - Android 2.1 - Android 2.2 - Android 2.3 - Android 4.0 	<ul style="list-style-type: none"> - Android 2.0 - Android 2.1 - Android 2.2 - Android 2.3 - Android 4.0 	-

12. APPEARANCE STANDARD

The appearance inspection is performed in a dark room around 500~1000 lx based on the conditions as below:

- The distance between inspector's eyes and display is 30 cm.
- The viewing zone is defined with angle θ shown in Fig. 12.1 The inspection should be performed within 45° when display is shut down. The inspection should be performed within 5° when display is power on.

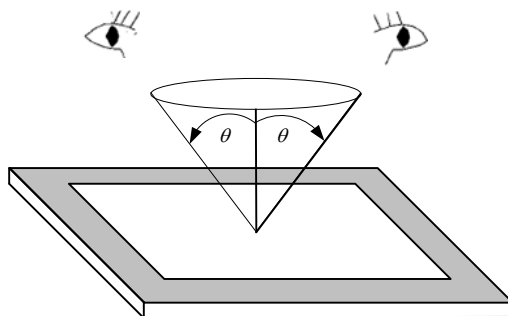

Fig. 12.1

12.1 THE DEFINITION OF LCD ZONE

LCD panel is divided into 3 areas as shown in Fig.12.2 for appearance specification in next section. A zone is the LCD active area (dot area); B zone is the area, which extended 1 mm out from LCD active area; C zone is the area between B zone and touch panel (O.D).

In terms of housing design, B zone is the recommended window area customers' housing should be located in.

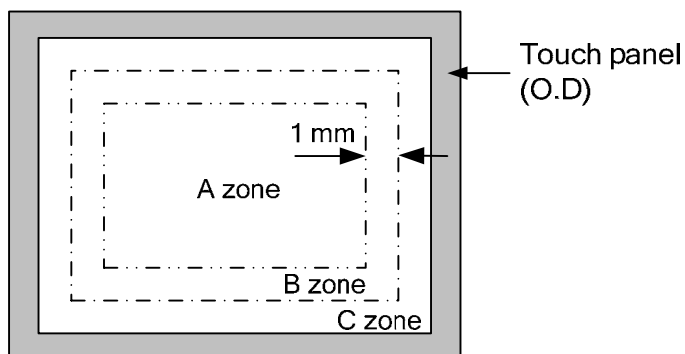

Fig. 12.2

12.2 LCD APPEARANCE SPECIFICATION

The specification as below is defined as the amount of unexpected phenomenon or material in different zones of LCD panel.

Item	Criteria				Applied zone
Scratches	Length (mm)	Width (mm)	Maximum number	Minimum space	A
	Ignored	$W \leq 0.01$	Ignored	-	
	$L \leq 40$	$W \leq 0.02$	10	-	
	$L \leq 20$	$W \leq 0.04$	10	-	
	Round (Dot Shape)				
	Average diameter (mm)	Maximum number	Minimum space		
	$D \leq 0.2$	Ignore	-		
	$D \leq 0.4$	10	-		
Dent	Serious one is not allowed				A
Wrinkles in polarizer	Serious one is not allowed				A
Bubbles on polarizer	Average diameter (mm)		Maximum number		A
	$D \leq 0.3$		Ignored		
	$D \leq 0.5$		10		
	$D \leq 1.0$		5		
1) Stains 2) Foreign Materials 3) Dark Spot	Filamentous (Line shape)				A
	Length (mm)	Width (mm)	Maximum number		
	Ignored	$W \leq 0.02$	Ignored		
	$L \leq 2.0$	$W \leq 0.03$	10		
	$L \leq 1.0$	$W \leq 0.06$	10		
	Round (Dot shape)				A
	Average diameter (mm)	Maximum number	Minimum Space		
	$D \leq 0.22$	Ignored	-		
	$D \leq 0.33$	5	-		
	$D > 0.33$	0	-		
	In total	Filamentous + Round=10			
Those wiped out easily are acceptable					
Dot-Defect (Note 1)		Type	Maximum number		A
	Bright dot-defect	1 dot	4		
		2 adjacent dot	1		
		3 adjacent dot or above	Not allowed		
		Density	$2(\phi 20\text{mm})$		
		In total	5		
	Dark dot-defect	1 dot	5		
		2 adjacent dot	2		
		3 adjacent dot or above	Not allowed		
		Density	$3(\phi 20\text{mm})$		
		In total	5		
In total		10			

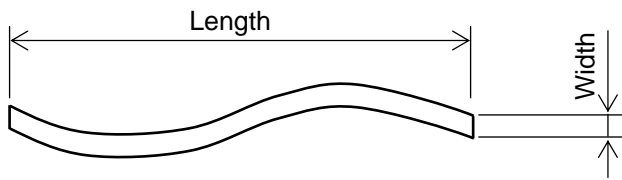

Fig 12.3

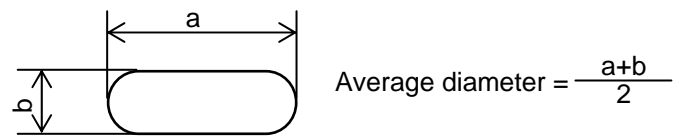

Fig 12.4

Note 1: The definitions of dot defect are as below:

- The defect area of the dot must be bigger than half of a dot.
- For bright dot-defect, showing black pattern, the dot's brightness must be over 30% brighter than others.
- For dark dot-defect, showing white pattern, the dot's brightness must be under 70% darker than others.
- The definition of 1-dot-defect is the defect-dot, which is isolated and no adjacent defect-dot.
- The definition of adjacent dot is shown as Fig. 12.5.
- The Density of dot defect is defined in the area within diameter $\phi = 20\text{mm}$.

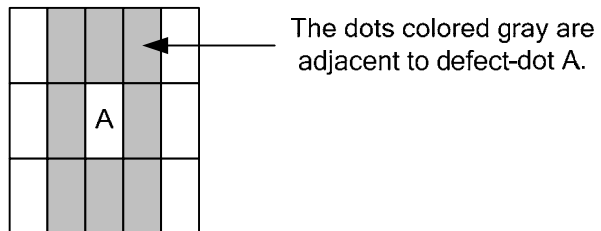

Fig 12.5

12.3 TOUCH PANEL APPEARANCE SPECIFICATION

The specification as below is defined by the amount of unexpected material in different zones of touch panel. The definitions of length, width and average diameter using in the table are shown in Fig. 12.3 and Fig. 12.4.

Item	Criteria			Applied zone
(1) Scratches (2) Line detect	Width (mm)	Length (mm)	Maximum number	A ,B C
	$W \geq 0.08$	$L > 8$	Not allowed	
	$0.08 \geq W > 0.05$	$8 \geq L > 2$	3 pcs max.	
	$W \geq 0.05$	$2 \geq L$	8 pcs max.	
Foreign Materials	Round (Dot shape)			A ,B ,C
	Average diameter (mm)		Maximum number	
	$D > 0.5$		Not allowed	
	$0.5 \geq D > 0.3$		2 pcs max.	
	$0.3 \geq D > 0.15$		10 pcs max.	
	$D \leq 0.15$		Ignored	

The limitation of glass flaw occurred on touch panel is defined in the table as below.

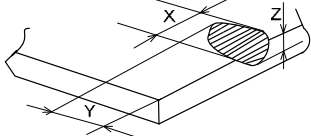
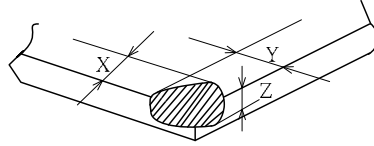
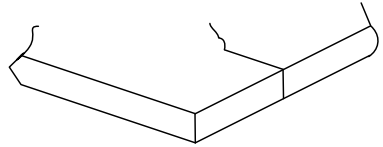
Item	Specifications	
Edge flaw		$X \leq 1.0 \text{ mm}$ $Y \leq 2.0 \text{ mm}$ $Z \leq 1/2T$
Corner flaw		$X \leq 1.0 \text{ mm}$ $Y \leq 2.5 \text{ mm}$ $Z \leq 1/2T$
Progressive flaw		Not allowed

13. PRECAUTIONS

13.1 PRECAUTIONS OF ESD

- 1) Before handling the display, please ensure your body has been connected to ground to avoid any damages by ESD. Also, do not touch display's interface directly when assembling.
- 2) Please remove the protection film very slowly before turning on the display to avoid generating ESD.

13.2 PRECAUTIONS OF HANDLING

- 1) In order to keep the appearance of display in good condition, please do not rub any surfaces of the displays by sharp tools harder than 7H, especially touch panel.
- 2) Please do not pile the displays in order to avoid any scars leaving on the display. In order to avoid any injuries, please pay more attention for the edges of glasses and metal frame, and wear finger cots to protect yourself and the display before working on it.
- 3) Touching the display area or the terminal pins with bare hand is prohibited. This is because it will stain the display area and cause poor insulation between terminal pins, and might affect display's electrical characteristics furthermore.
- 4) Do not use any harmful chemicals such as acetone, toluene, and isopropyl alcohol to clean display's surfaces.
- 5) Please use soft cloth or absorbent cotton with ethanol to clean the display by gently wiping. Moreover, when wiping the display, please wipe it by horizontal or vertical direction instead of circling to prevent leaving scars on the display's surface, especially polarizer.
- 6) Please wipe any unknown liquids immediately such as saliva, water or dew on the display to avoid color fading or any permanently damages.
- 7) Maximum pressure to the surface of the display must be less than $1,96 \times 10^4$ Pa. If the area of adding pressure is less than 1 cm^2 , the maximum pressure must be less than 1.96N.

13.3 PRECAUTIONS OF OPERATING

- 1) Please input signals and voltages to the displays according to the values defined in the section of electrical characteristics to obtain the best performance. Any voltages over than absolute maximum rating will cause permanent damages to this display. Also, any timing of the signals out of this specification would cause unexpected performance.
- 2) When the display is operating at significant low temperature, the response time will be slower than it at 25°C . In high temperature, the color will be slightly dark and blue compared to original pattern. However, these are temperature-related phenomenon of LCD and it will not cause permanent damages to the display when used within the operating temperature.
- 3) The use of screen saver or sleep mode is recommended when static images are likely for long periods of time. This is to avoid the possibility of image sticking.
- 4) Spike noise can cause malfunction of the circuit. The recommended limitation of spike noise is no bigger than $\pm 100 \text{ mV}$.

13.4 PRECAUTIONS of TOUCH PANEL

The housing should not cover the active area of touch panel.

13.5 PRECAUTIONS of STORAGE

If the displays are going to be stored for years, please be aware the following notices.

- 1) Please store the displays in a dark room to avoid any damages from sunlight and other sources of UV light.
- 2) The recommended long term storage temperature is between 10C° ~35C° and 55%~75% humidity to avoid causing bubbles between polarizer and LCD glasses, and polarizer peeling from LCD glasses.
- 3) It would be better to keep the displays in the container, which is shipped from Hitachi, and do not unpack it.
- 4) Please do not stick any labels on the display surface for a long time, especially on the polarizer.

14. DESIGNATION OF LOT MARK

1) The lot mark is showing in Fig.14.1. First 4 digits are used to represent production lot, T represented made in Taiwan, and the last 6 digits are the serial number.

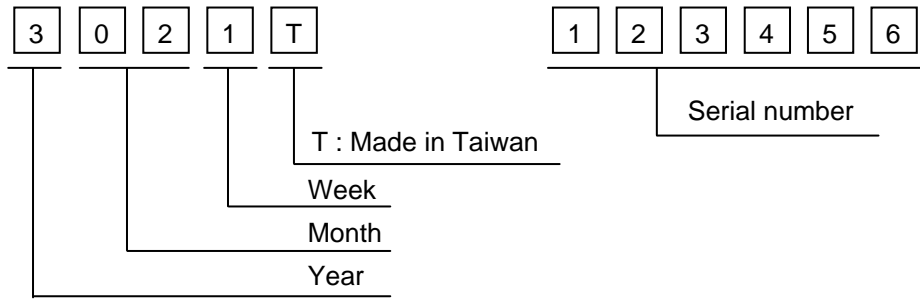

2) The tables as below are showing what the first 4 digits of lot mark are shorted for.

Year	Mark
2013	3
2014	4
2015	5
2016	6
2017	7

Month	Mark	Month	Mark
1	01	7	07
2	02	8	08
3	03	9	09
4	04	10	10
5	05	11	11
6	06	12	12

Week (Days)	Mark
1~7	1
8~14	2
15~21	3
22~28	4
29~31	5

3) Except letters I and O, revision number will be shown on lot mark and following letters A to Z.

4) The location of the lot mark is on the back of the display shown in Fig. 14.1.

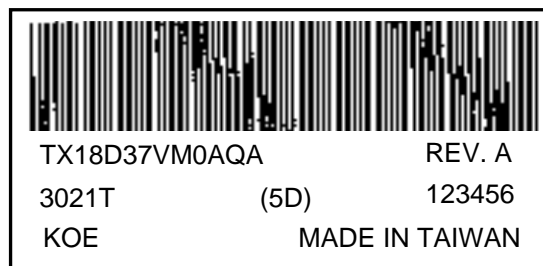

Fig 14.1