

# KOE

## JDI Group

TENTATIVE

Kaohsiung Opto-Electronics Inc.

FOR MESSRS : \_\_\_\_\_

DATE : Jul. 14<sup>th</sup> ,2014

### TECHNICAL DATA

## TX31D201VM0BAA

### Contents

No.	ITEM	SHEET No.	PAGE
1	COVER	7B64LTD-2450-1	1-1/1
2	RECORD OF REVISION	7B64LTD-2450-1	2-1/1
3	GENERAL DATA	7B64LTD-2450-1	3-1/1
4	ABSOLUTE MAXIMUM RATINGS	7B64LTD-2450-1	4-1/1
5	ELECTRICAL CHARACTERISTICS	7B64LTD-2450-1	5-1/2~2/2
6	OPTICAL CHARACTERISTICS	7B64LTD-2450-1	6-1/2~2/2
7	BLOCK DIAGRAM	7B64LTD-2450-1	7-1/1
8	LCD INTERFACE	7B64LTD-2450-1	8-1/7~7/7
9	OUTLINE DIMENSIONS	7B64LTD-2450-1	9-1/2~2/2

ACCEPTED BY: \_\_\_\_\_

PROPOSED BY: 

## 2. RECORD OF REVISION

DATE	SHEET No.	SUMMARY

### 3. GENERAL DATA

#### 3.1 DISPLAY FEATURES

This module is a 12.3" HSXGA of 8:3 format of amorphous silicon TFT. The pixel format is vertical stripe and sub pixels are arranged as R(red), G(green), B(blue) sequentially .This display is RoHS compliant , and COG (chip on glass) technology and LED backlight are applied on this display.

Part Name	TX31D201VM0BAA
Module Dimensions	320.0(W) mm x 130.0(H) mm x 12.1 (D) mm
LCD Active Area	291.84(W) mm x 109.44(H) mm
Pixel Pitch	0.228(W) mm x 0.228(H) mm
Resolution	1280 x 3(RGB)(W) x 480(H) dots
Color Pixel Arrangement	R, G, B Vertical stripe
LCD Type	Transmissive Color TFT; Normally Black
Display Type	Active Matrix
Number of Colors	16.7M Colors (8-bit RGB)
Backlight	Light Emitting Diode (LED)
Weight	540 g
Interface	LVDS ; 20 pins
Power Supply Voltage	3.3V for LCD; 18V for Backlight
Power Consumption	1.7 W for LCD ;3.6W for backlight
Viewing Direction	Super Wide Version (In Plane Switching)

## 4. ABSOLUTE MAXIMUM RATINGS

Item	Symbol	Min.	Max.	Unit	Remarks
Supply Voltage	$V_{DD}$	-0.3	4.0	V	-
Input Voltage of Logic	$V_I$	-0.3	$V_{DD}+0.3$	V	Note 1
Operating Temperature	$T_{op}$	-30	80	°C	Note 2
Storage Temperature	$T_{st}$	-40	90	°C	Note 2
LED Forward Current	$I_F$	-	150	mA	-

Note 1: The rating is defined for the signal voltages of the interface such as CLK and pixel data pairs.

Note 2: The maximum rating is defined as above based on the chamber temperature, which might be different from ambient temperature after assembling the panel into the application. Moreover, some temperature-related phenomenon as below needed to be noticed:

- Background color, contrast and response time would be different in temperatures other than 25°C.
- Operating under high temperature will shorten LED lifetime.

## 5. ELECTRICAL CHARACTERISTICS

### 5.1 LCD CHARACTERISTICS

$T_a = 25\text{ }^\circ\text{C}$ ,  $V_{SS} = 0\text{V}$

Item	Symbol	Condition	Min.	Typ.	Max.	Unit	Remarks
Power Supply Voltage	$V_{DD}$	-	3.0	3.3	3.6	V	-
Differential Input Voltage for LVDS Receiver Threshold	$V_I$	"H" level	-	-	+100	mV	Note 1
		"L" level	-100	-	-		
Power Supply Current	$I_{DD}$	$V_{DD}-V_{SS}=3.3\text{V}$	-	520	620	mA	Note 2,3
Frame Frequency	$f_{Frame}$	-	55	60	65	Hz	-
CLK Frequency	$f_{CLK}$	-	39.6	43.2	46.8	MHz	

Note 1: VCM 1.2V is common mode voltage of LVDS transmitter and receiver. The input terminal of LVDS receiver is terminated with  $100\Omega$ .

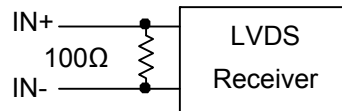

Note 2: An all white pattern is used when measuring  $I_{DD}$ .  $f_{Frame}$  is set to 60Hz.

Note 3: 1.0 A fuse is applied in the module for  $I_{DD}$ . For display activation and protection purpose, power supply is recommended larger than 2.5A to start the display and break fuse once any short circuit occurred.

## 5.2 BACKLIGHT CHARACTERISTICS

$T_a = 25\text{ }^\circ\text{C}$

Item	Symbol	Condition	Min.	Typ.	Max.	Unit	Remarks
Input Voltage	$V_{LED}$	$I_{LED} = 50\text{mA}$	-	18V	27.2	V	Note1
Input Current/per chain	$I_{LED}$	-	-	50mA	-	mA	Note1
LED lifetime	-	$I_{LED} = 50\text{mA}$	-	70K	-	hrs	Note 2

Note 1: As Fig. 5.1 shown LED current is constant 50 mA, need to be controlled by the LED driver when applying 18V  $V_{LED}$ .

Note 2: The estimated lifetime is specified as the time to reduce 50% brightness by applying 50 mA at  $25\text{ }^\circ\text{C}$ .

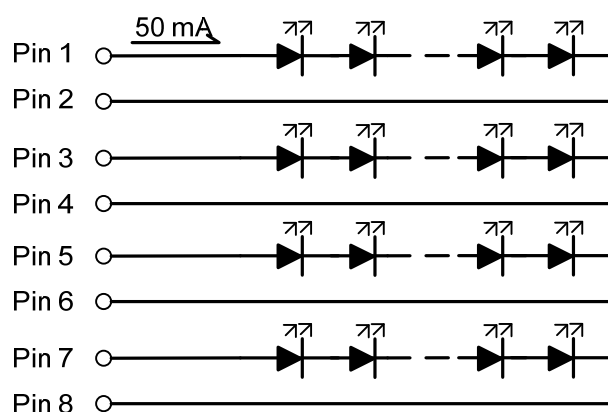

Fig. 5.1

## 6. OPTICAL CHARACTERISTICS

The optical characteristics are measured based on the conditions as below:

- Supplying the signals and voltages defined in the section of electrical characteristics.
- The backlight unit needs to be turned on for 30 minutes.
- The ambient temperature is 25 °C .
- In the dark room less than 100 lx, the equipment has been set for the measurements as shown in Fig 6.1.

$$T_a = 25\text{ }^\circ\text{C}, f_{\text{Frame}} = 60\text{Hz}, V_{\text{DD}} = 3.3\text{V}$$

Item	Symbol	Condition	Min.	Typ.	Max.	Unit	Remarks	
Brightness of White	-	$\phi = 0^\circ, \theta = 0^\circ,$ $I_{\text{LED}} = 50\text{mA}/\text{chain}$	400	500	-	cd/m <sup>2</sup>	Note 1	
Brightness Uniformity	-		70	-	-	%	Note 2	
Contrast Ratio	CR		400	800	-	-	Note 3	
Response Time (Rising + Falling)	Tr + Tf	$\phi = 0^\circ, \theta = 0^\circ$	-	25	-	ms	Note 4	
NTSC Ratio	-	$\phi = 0^\circ, \theta = 0^\circ$	-	70	-	%	-	
Viewing Angle	$\theta_x$	$\phi = 0^\circ, \text{CR} \geq 10$	-	85	-	Degree	Note 5	
	$\theta_{x'}$	$\phi = 180^\circ, \text{CR} \geq 10$	-	85	-			
	$\theta_y$	$\phi = 90^\circ, \text{CR} \geq 10$	-	85	-			
	$\theta_{y'}$	$\phi = 270^\circ, \text{CR} \geq 10$	-	85	-			
Color Chromaticity	Red	X	$\phi = 0^\circ, \theta = 0^\circ$	0.57	0.62	0.67	-	Note 6
		Y		0.31	0.36	0.41		
	Green	X		0.25	0.30	0.35		
		Y		0.57	0.62	0.67		
	Blue	X		0.09	0.14	0.19		
		Y		0.02	0.07	0.12		
	White	X		0.25	0.30	0.35		
		Y		0.26	0.31	0.36		

Note 1: The brightness is measured from the panel center point, P5 in Fig. 6.2, for the typical value.

Note 2: The brightness uniformity is calculated by the equation as below:

$$\text{Brightness uniformity} = \frac{\text{Min. Brightness}}{\text{Max. Brightness}} \times 100\%$$

which is based on the brightness values of the 9 points in active area measured by BM-5 as shown in Fig. 6.2.

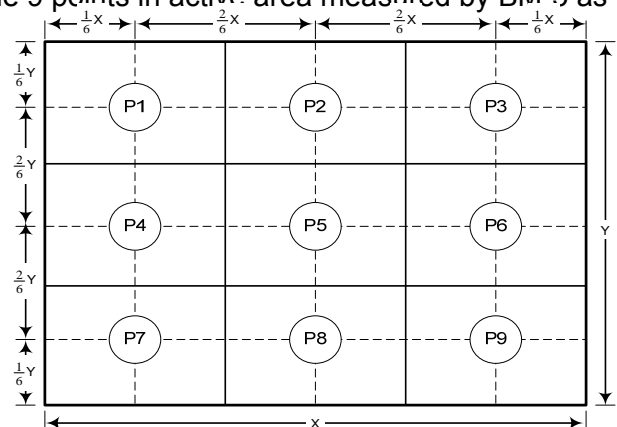
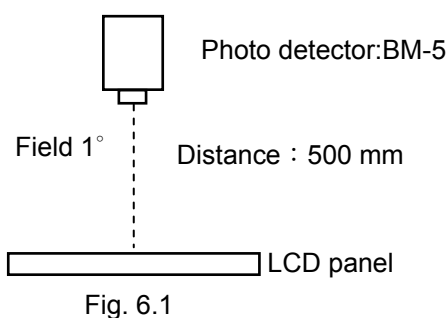

Note 3: The Contrast Ratio is measured from the center point of the panel, P5, and defined as the following equation:

$$CR = \frac{\text{Brightness of White}}{\text{Brightness of Black}}$$

Note 4: The definition of response time is shown in Fig. 6.3. The rising time is the period from 10% brightness to 90% brightness when the data is from black to white. Oppositely, Falling time is the period from 90% brightness falling to 10% brightness.

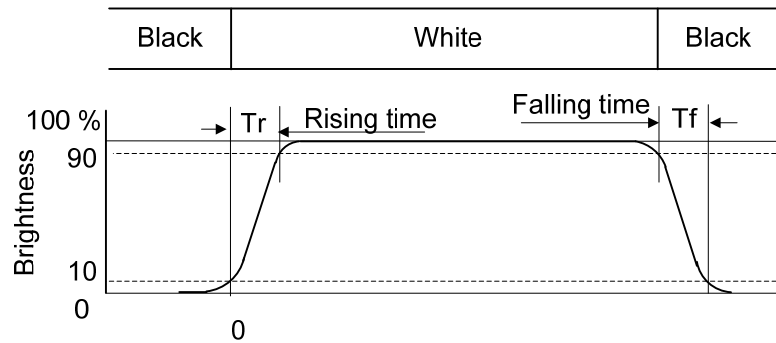

Fig . 6.3

Note 5: The definition of viewing angle is shown in Fig. 6.4. Angle  $\phi$  is used to represent viewing directions, for instance,  $\phi = 270^\circ$  means 6 o'clock, and  $\phi = 0^\circ$  means 3 o'clock. Moreover, angle  $\theta$  is used to represent viewing angles from axis Z toward plane XY.

The display is super wide viewing angle version;  $85^\circ$  viewing angle can be obtained from each viewing direction.

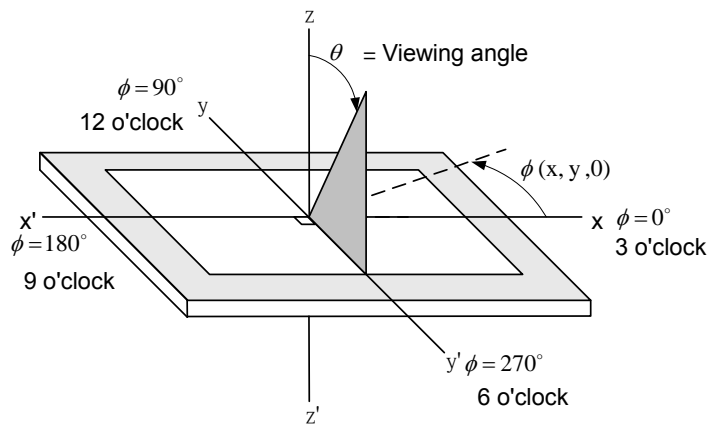
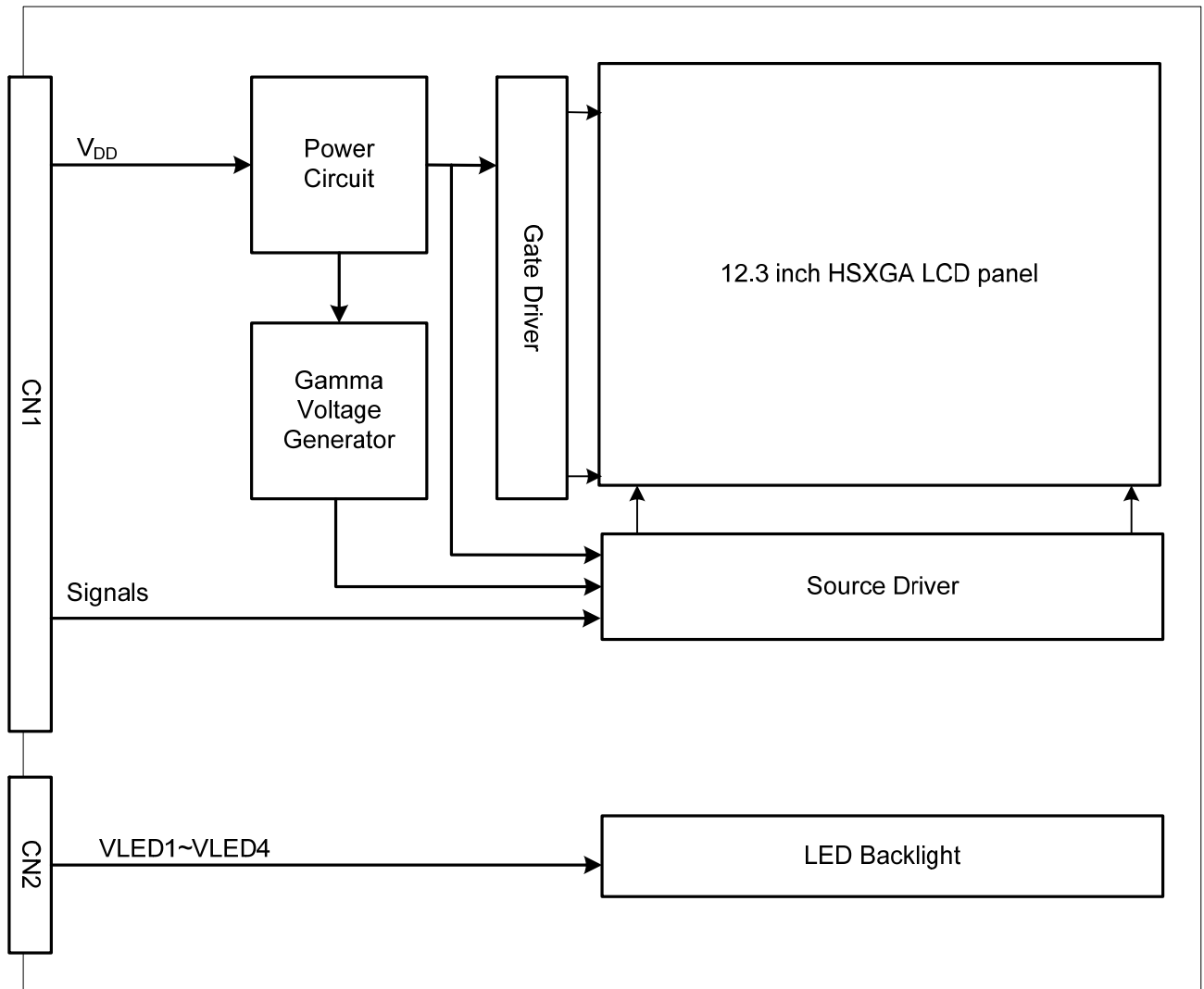

Fig 6.4

Note 6: The color chromaticity is measured from the center point of the panel, P5, as shown in Fig. 6.2.



# 7. BLOCK DIAGRAM



Note : Signals are CLK and pixel data pairs.

## 8. LCD INTERFACE

### 8.1 INTERFACE PIN CONNECTIONS

The display interface connector CN1 is FI-SEB20P-HF13E made by JAE and pin assignment is as below:

Pin No.	Signal	Signal	Pin No.	Signal	Signal
1	V <sub>DD</sub>	Power Supply for Logic	11	IN2-	Pixel Data
2	V <sub>DD</sub>		12	IN2+	
3	V <sub>SS</sub>	GND	13	V <sub>SS</sub>	GND
4	V <sub>SS</sub>		14	CLK IN-	Pixel Clock
5	IN0-	Pixel Data	15	CLK IN+	
6	IN0+		16	V <sub>SS</sub>	GND
7	V <sub>SS</sub>	GND	17	IN3-	Pixel Data
8	IN1-	Pixel Data	18	IN3+	
9	IN1+		19	SD	Scan Direction Control (Note 1)
10	V <sub>SS</sub>	GND	20	NC	No Connection

Note 1: Scan direction is available to be switched as below.

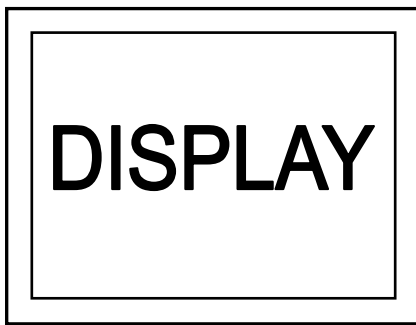

SD : Low or Open (Default)



SD : High

Note 2: IN<sub>n</sub>- and IN<sub>n</sub>+ (n=0,1,2,3), CLK IN- and CLK IN+ should be wired by twist-pairs or side-by-side FPC patterns, respectively.

The backlight interface connector CN2 is SM08B-SRSS-TB made by JST, and pin assignment is as below:

Pin No.	Signal	Level	Function
1	VLED1(+)	-	Power Supply for LED chain 1
2	VLED1(-)	-	
3	VLED2(+)	-	Power Supply for LED chain 2
4	VLED2(-)	-	
5	VLED3(+)	-	Power Supply for LED chain 3
6	VLED3(-)	-	
7	VLED4(+)	-	Power Supply for LED chain 4
8	VLED4(-)	-	

## 8.2 LVDS INTERFACE

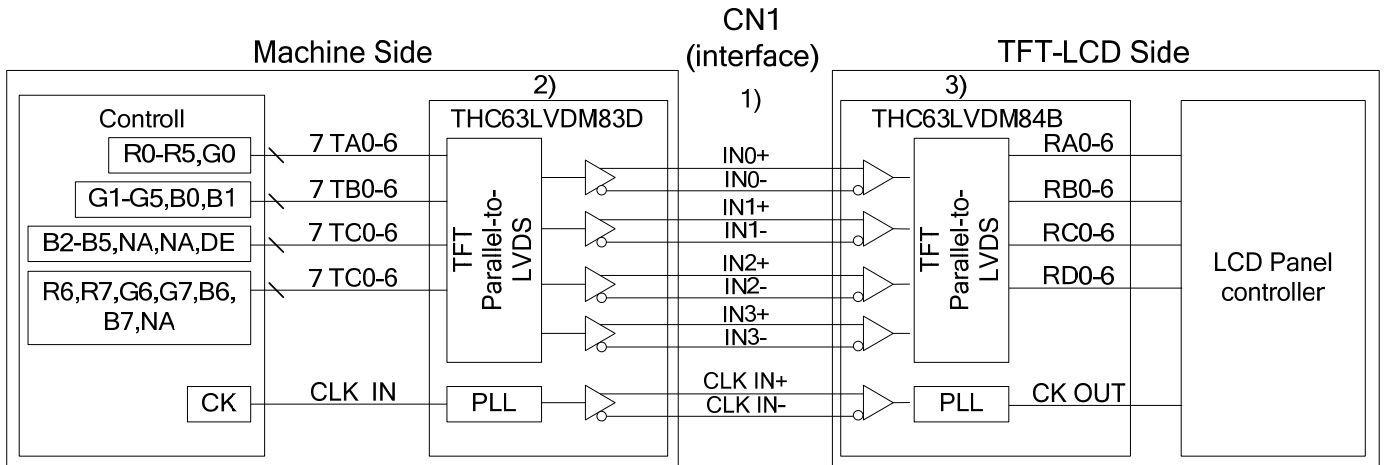

Note 1: LVDS cable impedance should be 100 ohms per signal line when each 2-lines (+,-) is used in differential mode.

Note 2: The recommended transmitter, THT63LVDM83R, is made by Thine or equivalent, which is not contained in the module.

Note 3: The receiver built-in the module is THT63LVDM84B.

## 9.3 LVDS DATA FORMAT

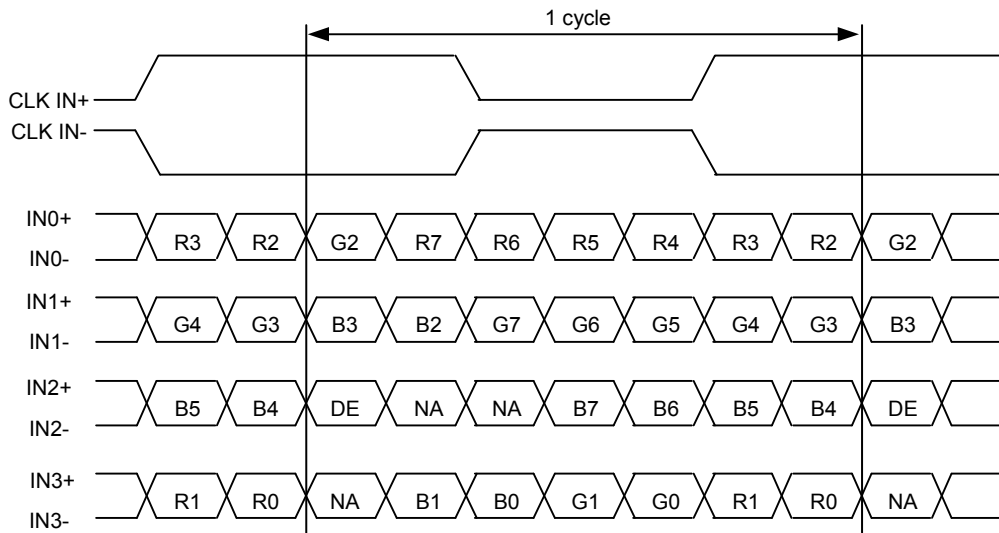

DE: Display Enable

NA: Not Available

## 8.4 TIMING CHART

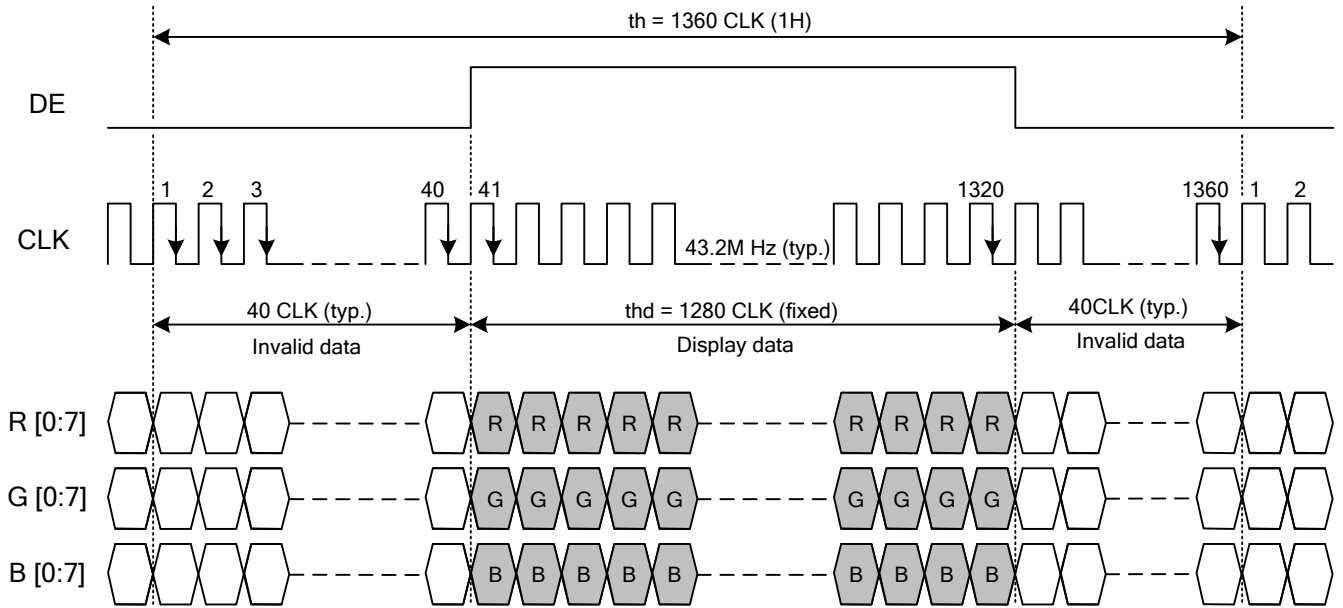

Fig. 8.1 Horizontal Timing

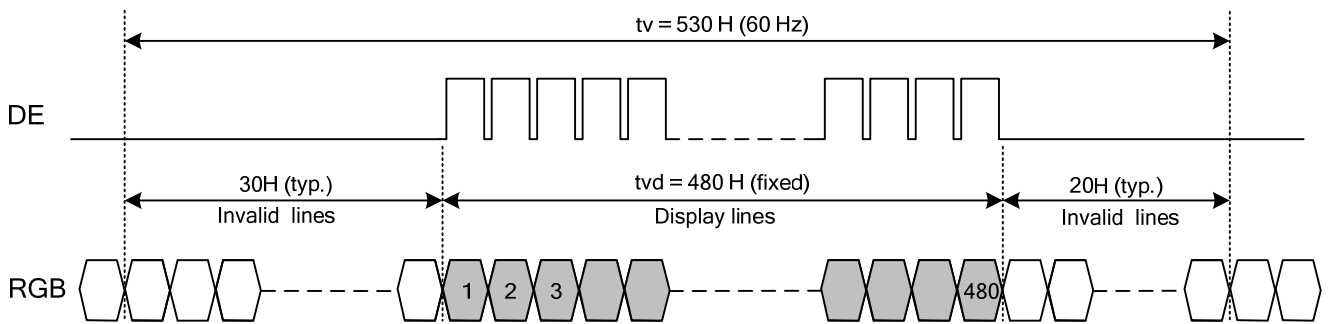

Fig. 8.2 Vertical Timing

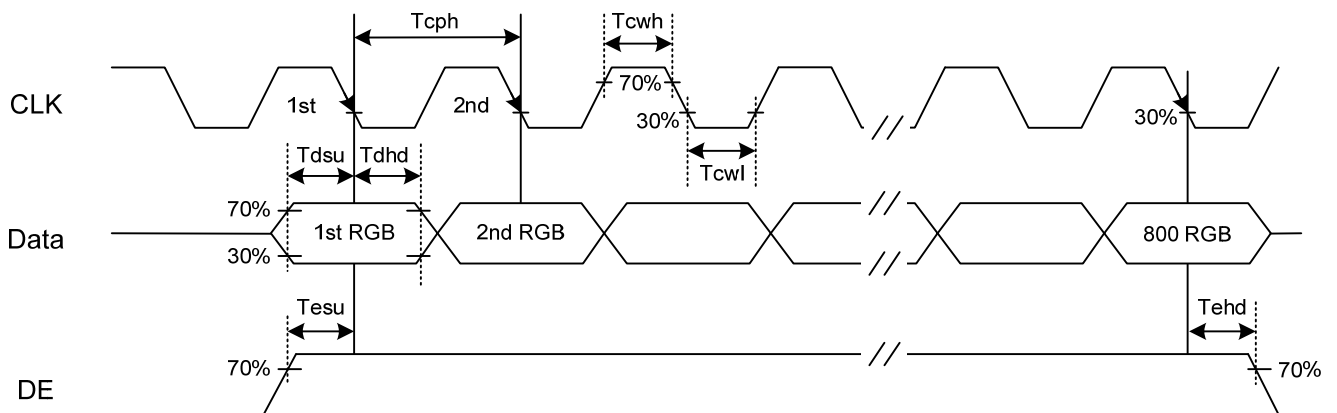

Fig. 8.3 Setup & Hold Time

## 8.5 TIME TABLE

The column of timing sets including minimum, typical, and maximum as below are based on the best optical performance, frame frequency (Vsync) = 60 Hz to define. If 60 Hz is not the aim to set, less than 66 Hz for Vsync is recommended to apply for better performance by other parameter combination as the definitions in section 5.1.

### A. Horizontal and Vertical Timing

Item		Symbol	Min.	Typ.	Max.	Unit
Horizontal	CLK Frequency	fclk	39.6	43.2	48	M Hz
	Display Data	thd	1280			CLK
	Cycle Time	th	1320	1360	1400	
Vertical	Display Data	tvd	480			H
	Cycle Time	tv	500	530	555	

### B. Setup and Hold Time

Item		Symbol	Min.	Typ.	Max.	Unit
CLK	Duty	Tcwh	40	50	60	%
	Cycle Time	Tcph	18.5	23	-	ns
Data	Setup Time	Tdsu	8	-	-	
	Hold Time	Tdhd	8	-	-	
DE	Setup Time	Tesu	8	-	-	
	Hold Time	Tehd	8	-	-	

## 8.6 LVDS RECEIVER TIMING

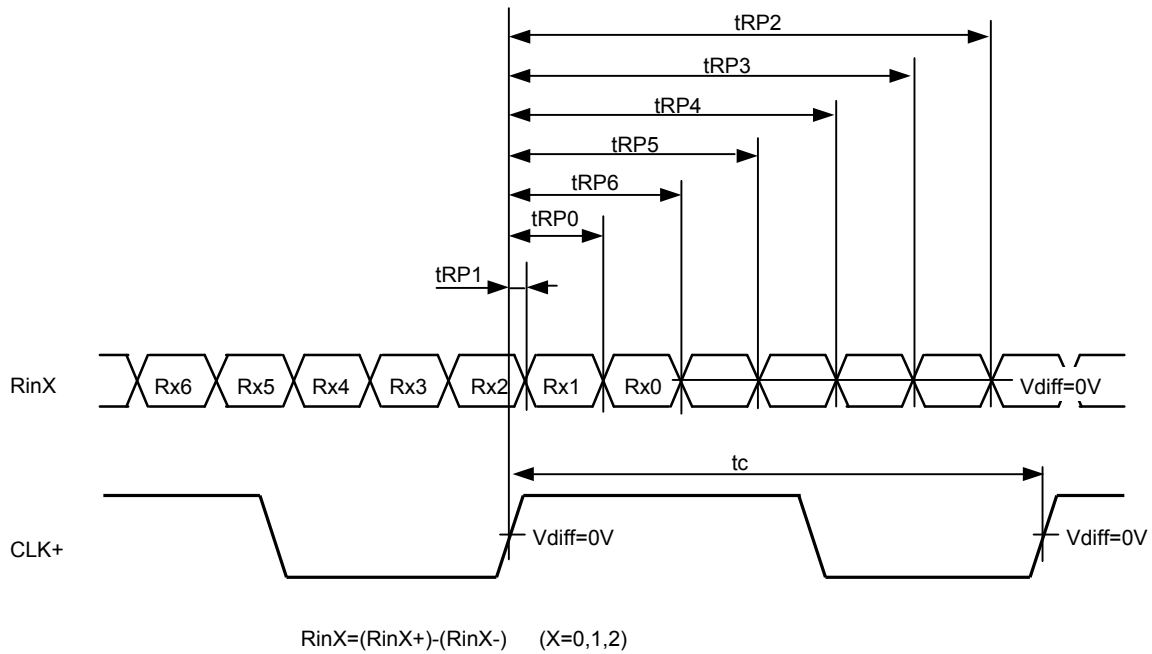

	Item	Symbol	Min.	Typ.	Max.	Unit
CLK	Cycle frequency	$1/t_{CLK}$	39.6	43.2	48	MHz
R <sub>inX</sub> (X=0,1,2,3)	0 data position	t <sub>RP0</sub>	$1/7 * t_{CLK} - 0.4$	$1/7 * t_{CLK}$	$1/7 * t_{CLK} + 0.4$	ns
	1st data position	t <sub>RP1</sub>	-0.4	0	+0.4	
	2nd data position	t <sub>RP2</sub>	$6/7 * t_{CLK} - 0.4$	$6/7 * t_{CLK}$	$6/7 * t_{CLK} + 0.4$	
	3rd data position	t <sub>RP3</sub>	$5/7 * t_{CLK} - 0.4$	$5/7 * t_{CLK}$	$5/7 * t_{CLK} + 0.4$	
	4th data position	t <sub>RP4</sub>	$4/7 * t_{CLK} - 0.4$	$4/7 * t_{CLK}$	$4/7 * t_{CLK} + 0.4$	
	5th data position	t <sub>RP5</sub>	$3/7 * t_{CLK} - 0.4$	$3/7 * t_{CLK}$	$3/7 * t_{CLK} + 0.4$	
	6th data position	t <sub>RP6</sub>	$2/7 * t_{CLK} - 0.4$	$2/7 * t_{CLK}$	$2/7 * t_{CLK} + 0.4$	

## 9.7 DATA INPUT for DISPLAY COLOR

Input		Red Data								Green Data								Blue Data															
		R7	R6	R5	R4	R3	R2	R1	R0	G7	G6	G5	G4	G3	G2	G1	G0	B7	B6	B5	B4	B3	B2	B1	B0								
color		MSB								LSB								MSB								LSB							
Basic Color	Black	0	0	0	0	0	0	0	0	0	0	0	0	0	0	0	0	0	0	0	0	0	0	0	0								
	Red(255)	1	1	1	1	1	1	1	1	0	0	0	0	0	0	0	0	0	0	0	0	0	0	0									
	Green(255)	0	0	0	0	0	0	0	0	1	1	1	1	1	1	1	0	0	0	0	0	0	0	0									
	Blue(255)	0	0	0	0	0	0	0	0	0	0	0	0	0	0	0	1	1	1	1	1	1	1	1									
	Cyan	0	0	0	0	0	0	0	0	1	1	1	1	1	1	1	1	1	1	1	1	1	1	1									
	Magenta	1	1	1	1	1	1	1	1	0	0	0	0	0	0	0	1	1	1	1	1	1	1	1									
	Yellow	1	1	1	1	1	1	1	1	1	1	1	1	1	1	1	0	0	0	0	0	0	0	0									
	White	1	1	1	1	1	1	1	1	1	1	1	1	1	1	1	1	1	1	1	1	1	1	1									
Red	Black	0	0	0	0	0	0	0	0	0	0	0	0	0	0	0	0	0	0	0	0	0	0	0									
	Red(1)	0	0	0	0	0	0	0	1	0	0	0	0	0	0	0	0	0	0	0	0	0	0	0									
	Red(2)	0	0	0	0	0	0	1	0	0	0	0	0	0	0	0	0	0	0	0	0	0	0	0									
	:	:	:	:	:	:	:	:	:	:	:	:	:	:	:	:	:	:	:	:	:	:	:	:									
	:	:	:	:	:	:	:	:	:	:	:	:	:	:	:	:	:	:	:	:	:	:	:	:									
	Red(253)	1	1	1	1	1	1	0	1	0	0	0	0	0	0	0	0	0	0	0	0	0	0	0									
	Red(254)	1	1	1	1	1	1	1	0	0	0	0	0	0	0	0	0	0	0	0	0	0	0	0									
	Red(255)	1	1	1	1	1	1	1	1	0	0	0	0	0	0	0	0	0	0	0	0	0	0	0									
Green	Black	0	0	0	0	0	0	0	0	0	0	0	0	0	0	0	0	0	0	0	0	0	0	0									
	Green(1)	0	0	0	0	0	0	0	0	0	0	0	0	0	0	1	0	0	0	0	0	0	0	0									
	Green(2)	0	0	0	0	0	0	0	0	0	0	0	0	0	1	0	0	0	0	0	0	0	0	0									
	:	:	:	:	:	:	:	:	:	:	:	:	:	:	:	:	:	:	:	:	:	:	:	:									
	:	:	:	:	:	:	:	:	:	:	:	:	:	:	:	:	:	:	:	:	:	:	:	:									
	Green(253)	0	0	0	0	0	0	0	0	1	1	1	1	1	1	0	1	0	0	0	0	0	0	0									
	Green(254)	0	0	0	0	0	0	0	0	1	1	1	1	1	1	0	0	0	0	0	0	0	0	0									
	Green(255)	0	0	0	0	0	0	0	0	1	1	1	1	1	1	1	0	0	0	0	0	0	0	0									
Blue	Black	0	0	0	0	0	0	0	0	0	0	0	0	0	0	0	0	0	0	0	0	0	0	0									
	Blue(1)	0	0	0	0	0	0	0	0	0	0	0	0	0	0	0	0	0	0	0	0	0	0	1									
	Blue(2)	0	0	0	0	0	0	0	0	0	0	0	0	0	0	0	0	0	0	0	0	0	1	0									
	:	:	:	:	:	:	:	:	:	:	:	:	:	:	:	:	:	:	:	:	:	:	:	:									
	:	:	:	:	:	:	:	:	:	:	:	:	:	:	:	:	:	:	:	:	:	:	:	:									
	Blue(253)	0	0	0	0	0	0	0	0	0	0	0	0	0	0	0	1	1	1	1	1	1	0	1									
	Blue(254)	0	0	0	0	0	0	0	0	0	0	0	0	0	0	0	1	1	1	1	1	1	1	0									
	Blue(255)	0	0	0	0	0	0	0	0	0	0	0	0	0	0	0	1	1	1	1	1	1	1	1									

## 8.8 POWER SEQUENCE

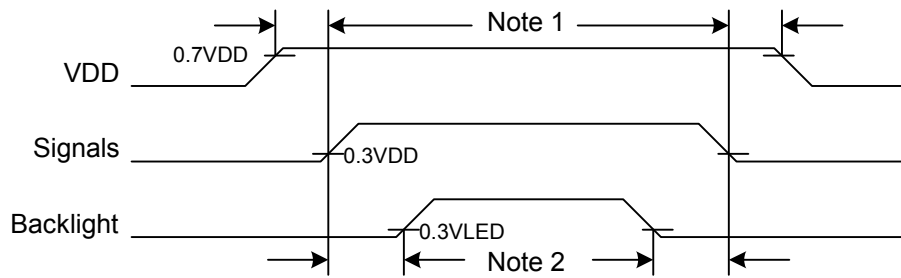

Note 1: In order to avoid any damages,  $V_{DD}$  has to be applied before all other signals. The opposite is true for power off where  $V_{DD}$  has to be remained on until all other signals have been switch off. The recommended time period is 1 second. Hot plugging might cause display damage due to incorrect power sequence, please pay attention on interface connecting before power on.

Note 2: In order to avoid showing uncompleted patterns in transient state. It is recommended that switching the backlight on is delayed for 1 second after the signals have been applied. The opposite is true for power off where the backlight has to be switched off 1 second before the signals are removed.



# 9. OUTLINE DIMENSIONS

## 9.1 FRONT VIEW

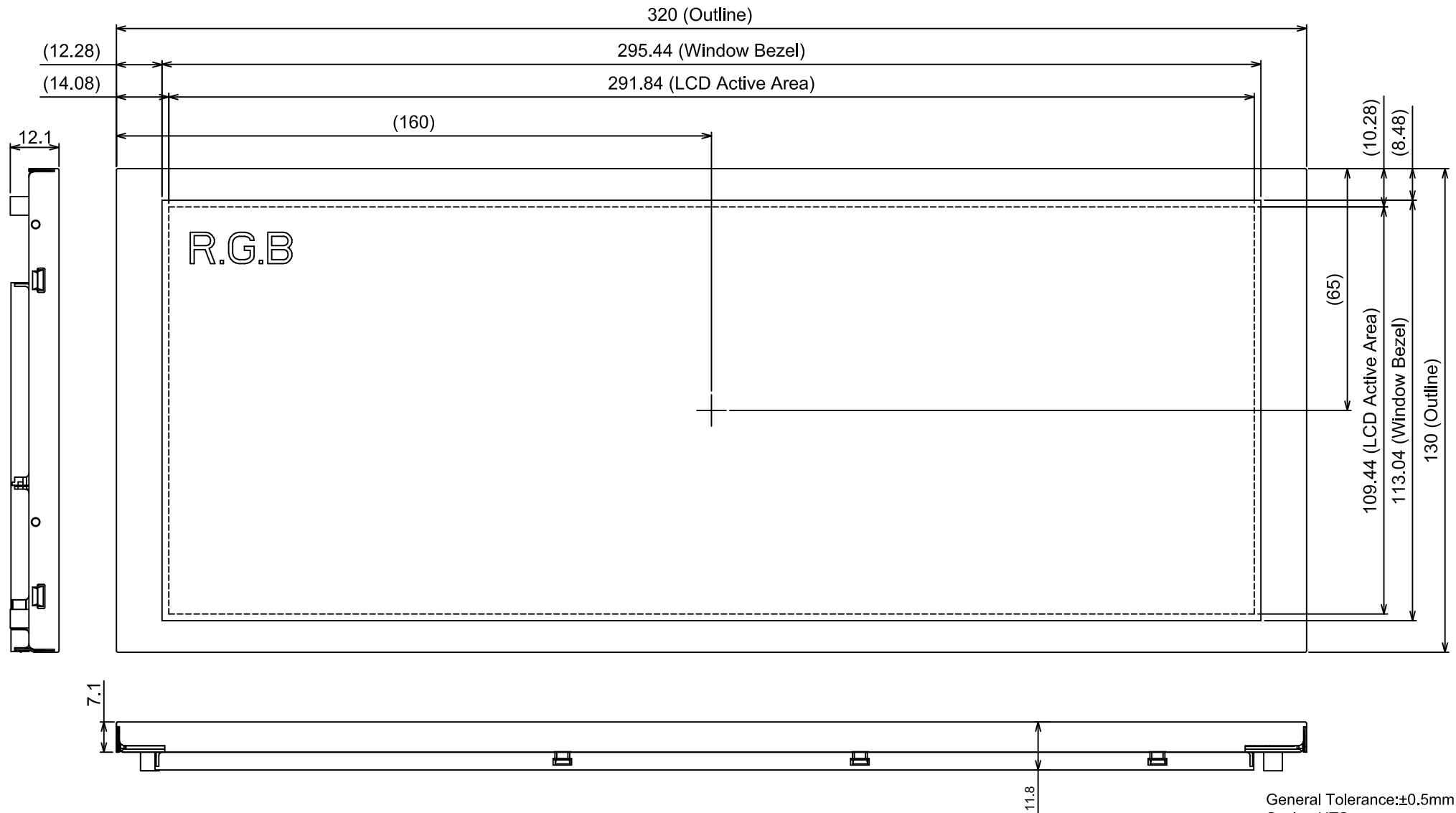

General Tolerance: ±0.5mm  
 Scale : NTS  
 Unit : mm

# 9.2 RAER VIEW

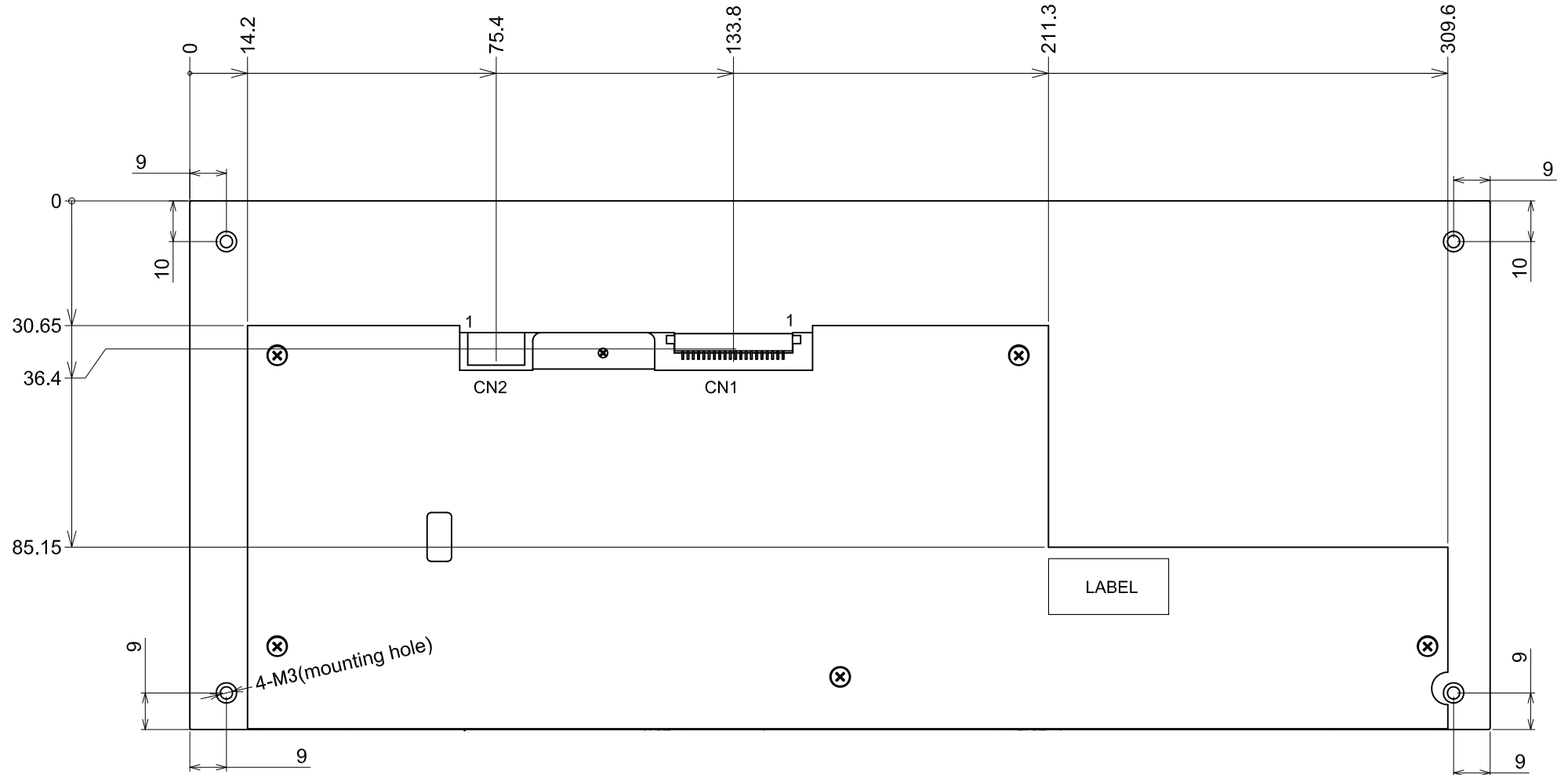

General Tolerance: ±0.5mm  
 Scale : NTS  
 Unit : mm