

Product Specification

SPECIFICATION FOR APPROVAL

- () Preliminary Specification
- () Final Specification

Title	7.85" XGA TFT LCD
-------	-------------------

Customer	
MODEL	

SUPPLIER	LG Display Co., Ltd.
*MODEL	LP079X01
Suffix	SMA1

*When you obtain standard approval,
please use the above model name without suffix

APPROVED BY	SIGNATURE
/	_____
/	_____
/	_____

APPROVED BY	SIGNATURE
S. W. Moon / S. Manager	_____
REVIEWED BY	
J. S. Kim / Manager	_____
PREPARED BY	
S. W. Song / Engineer	_____

Please return 1 copy for your confirmation with your signature and comments.

Product Engineering Dept.
LG Display Co., Ltd

Product Specification

Contents

No	ITEM	Page
	COVER	1
	CONTENTS	2
	RECORD OF REVISIONS	3
1	GENERAL DESCRIPTION	4
2	ABSOLUTE MAXIMUM RATINGS	5
3	ELECTRICAL SPECIFICATIONS	
3-1	ELECTRICAL CHARACTERISTICS	6
3-2	INTERFACE CONNECTIONS	7
3-3	MIPI SIGNAL TIMING SPECIFICATIONS	8
3-4	SIGNAL TIMING SPECIFICATIONS	11
3-5	SIGNAL TIMING WAVEFORMS	11
3-6	COLOR INPUT DATA REFERENCE	12
3-7	POWER SEQUENCE	13
4	OPTICAL SPECIFICATIONS	14
5	MECHANICAL CHARACTERISTICS	17
6	RELIABILITY	19
7	INTERNATIONAL STANDARDS	
7-1	SAFETY	20
7-2	EMC	20
8	PACKING	
8-1	DESIGNATION OF LOT MARK	21
8-2	PACKING FORM	21
9	PRECAUTIONS	22

Product Specification

1. General Description

The LP079X01 is a Color Active Matrix Liquid Crystal Display with an integral LED backlight system. The matrix employs a-Si Thin Film Transistor as the active element. It is a transmissive type display operating in the normally Black mode. This TFT-LCD has 7.85 inches diagonally measured active display area with XGA resolution(768 horizontal by 1024 vertical pixel array). Each pixel is divided into Red, Green and Blue sub-pixels or dots which are arranged in vertical stripes. Gray scale or the brightness of the sub-pixel color is determined with a 6-bit gray scale signal for each dot, thus, presenting a palette of more than 262,144 colors.

The LP079X01 has been designed to apply the interface method that enables low power, high speed, low EMI. The LP079X01 is intended to support applications where thin thickness, low power are critical factors and graphic displays are important. In combination with the vertical arrangement of the sub-pixels, the LP079X01 characteristics provide an excellent flat display for office automation products such as Notebook PC.

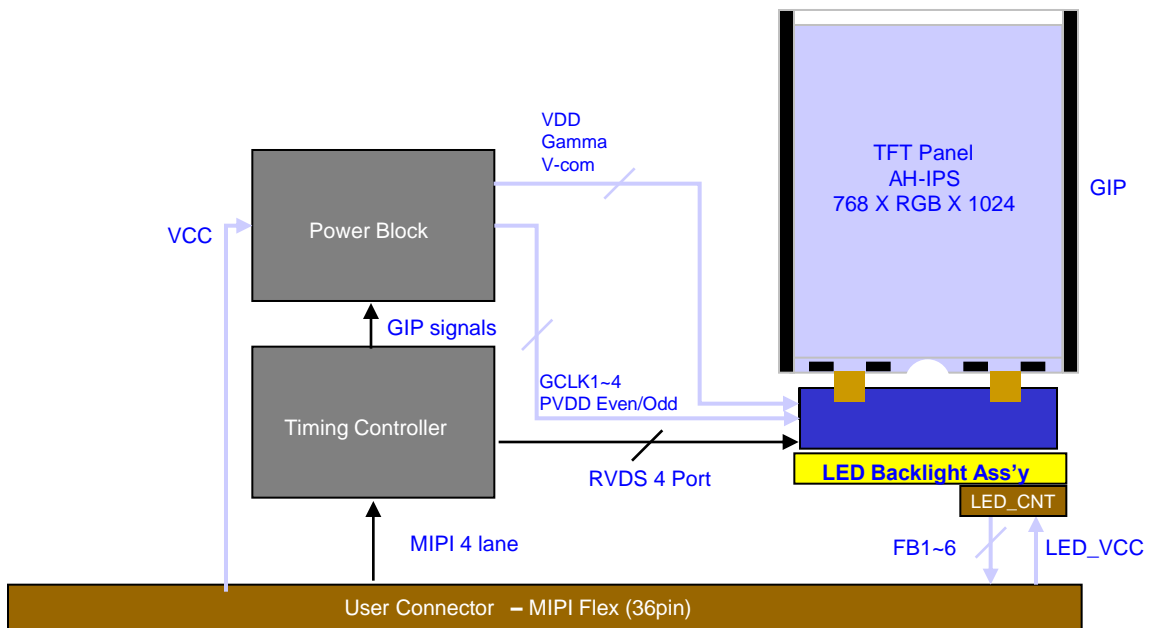

General Features

Active Screen Size	7.85 inches diagonal
Outline Dimension	129.00(H) × 171.07 (V) W/O C/Sheild × 1.96(D, Max.) mm
Pixel Pitch	119.808(H) × 159.744(V) [mm]
Pixel Format	768 horiz. by 1024 vert. Pixels RGB strip arrangement
Color Depth	6-bit, 262,144 colors
Luminance, White	425cd/m ² (Typ., @I _{LED} =21.8mA)
Power Consumption	2.22W(Typ.) [0.75W(Logic, Typ.) + 1.47W(LED, Typ.)]
Weight	70g (Max.)
Display Operating Mode	Transmissive mode, normally Black
Surface Treatment	Glare, hard coating treatment of the front polarizer

Product Specification

3. Electrical Specifications

3-1. Electrical Characteristics

The LP097X02 requires two power inputs. One is employed to power the LCD electronics and to drive the TFT array and liquid crystal. The second input which powers the LED BL.

Table 2. ELECTRICAL CHARACTERISTICS

Parameter	Symbol	Values			Unit	Notes
		Min	Typ	Max		
MODULE :						
Power Supply Input Voltage	VCC	3.0	3.6	5	V _{DC}	
Power Supply Input Current	I _{CC} Mosaic	155	183	210	mA	1
Power Consumption	P _c	-	0.66	0.76	Watt	1
LED Backlight :						
(Without LED Driver)						
LED Driver input Volatge (on system)	VLED			12	V	2
Operating Current per string	I _{LED}	21.2	21.8	22.3	mA	3
Power Consumption	P _{BL}		1.47		Watt	4
Life Time		10,000	-	-	Hrs	5

Note)

1. The specified current and power consumption are under the Vcc = 3.6V , 25°C, fv = 60Hz condition whereas Mosaic pattern is displayed and fv is the frame frequency.

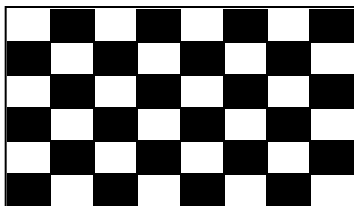

2. LED input voltage must be input below than 12V to operate normally for LED Driver.
3. The typical operating current is for the typical surface luminance (L_{WH}) in optical characteristics.
4. The LED power consumption shown above does not include power of external LED driver circuit for typical current condition.
5. The life time is determined as the time at which brightness of lamp is 50% compare to that of initial value at the typical lamp current.

Product Specification

3-2. Interface Connections

This LCD employs two interface connections, a 36 pin B2B connector is used for the module electronics interface and the other connector is used for the integral backlight system.

The electronics interface connector is a model AA07-PVA1 manufactured by JAE.

Table 3. MODULE CONNECTOR PIN CONFIGURATION (CN1)

Pin	Symbol	Description	Notes
1	GND	Ground	[MIPI Receiver] Samsung, S6TMR1
2	VCC	Power Supply	
3	R _{IN} 3-	Negative MIPI differential data input	[Connector] AA07-PVA1 (JAE), 36pin B2B Connector
4	VCC	Power Supply	
5	R _{IN} 3+	Positive MIPI differential data input	[Connector pin arrangement] LCD Rear View
6	VCC	Power Supply	
7	GND	Ground	
8	VCC	Power Supply	
9	R _{IN} 2-	Negative MIPI differential data input	
10	VCC	Power Supply	
11	R _{IN} 2+	Positive MIPI differential data input	
12	GND	Ground	
13	GND	Ground	
14	RESET	TCON Reset input	
15	R _{IN} 1-	Negative MIPI differential data input	
16	GND	Ground	
17	R _{IN} 1+	Positive MIPI differential data input	
18	FB3	LED Cathode (Negative)	
19	GND	Ground	
20	FB2	LED Cathode (Negative)	
21	R _{IN} 0-	Negative MIPI differential data input	
22	FB1	LED Cathode (Negative)	
23	R _{IN} 0+	Positive MIPI differential data input	
24	FB0	LED Cathode (Negative)	
25	GND	Ground	
26	FB4	LED Cathode (Negative)	
27	CLK-	Negative MIPI differential clock input	
28	FB5	LED Cathode (Negative)	
29	CLK+	Positive MIPI differential clock input	
30	LED_VCC	LED Anode (Positive)	
31	GND	Ground	
32	LED_VCC	LED Anode (Positive)	
33	GND	Ground	
34	GND	Ground	
35	GND	Ground	
36	GND	Ground	

Product Specification

3-3. MIPI Signal Timing Specifications

3-3-1. DC Specification

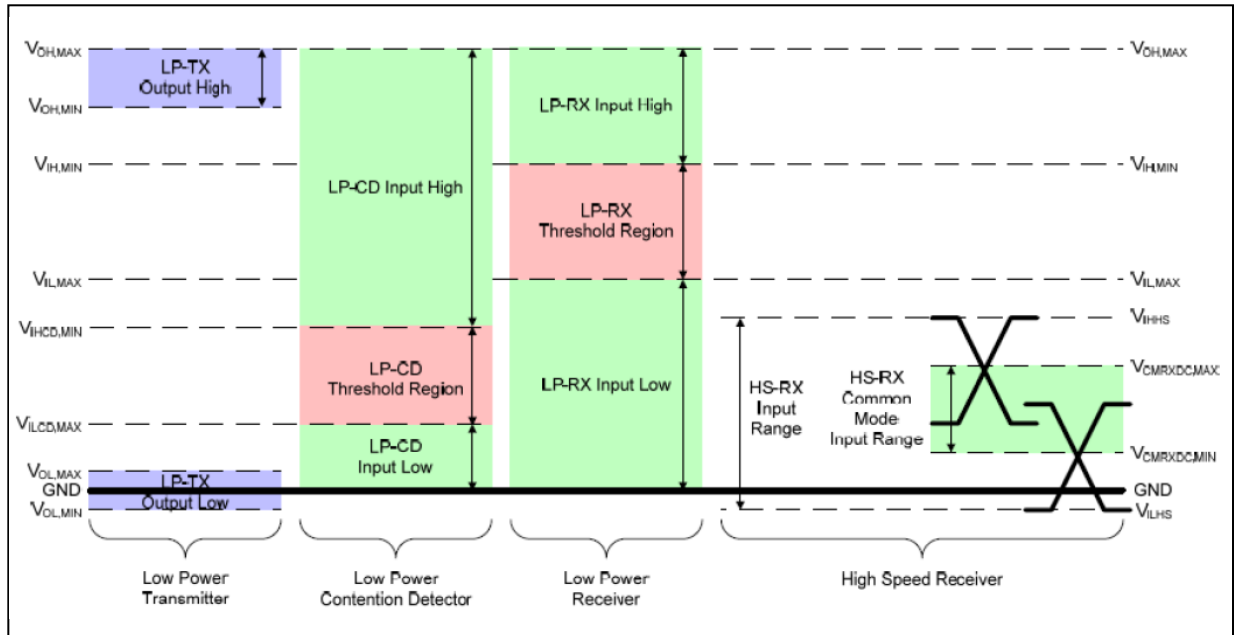

Description	Symbol	Condition	Min	Typ	Max	Unit
High level input voltage	V_{IH}	-	840	-	1500	mV
Low level input voltage	V_{IL}	-	-300	-	360	mV
High level output voltage	V_{OH}	$I_{OH} = 4\text{mA}$	840	-	-	mV
Low level output condition	V_{OL}	$I_{OL} = 4\text{mA}$	-	-	400	mV
Single-ended input high voltage	V_{IHHS}	-	-	-	460	mV
Differential input high threshold	V_{IDTH}	-	-	-	70	mV
Differential input low threshold	V_{IDTL}	-	-70	-	-	mV
Logic 1 contention threshold	V_{IHCD}	-	450	-	-	mV
Logic 0 contention threshold	V_{ILCD}	-	-	-	200	mV
Differential input impedance	Z_{ID}	-	80	100	125	Ω

Product Specification

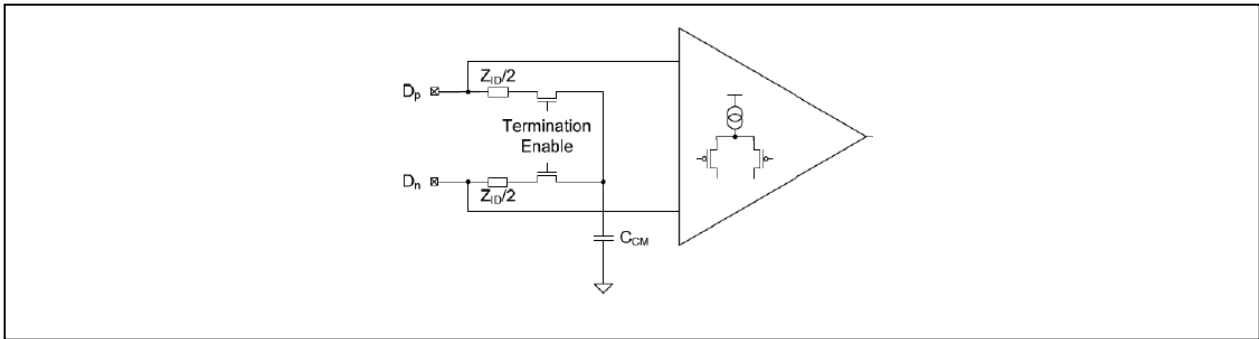

< Differential input of MIPI Receiver >

3-3-2. AC Specification

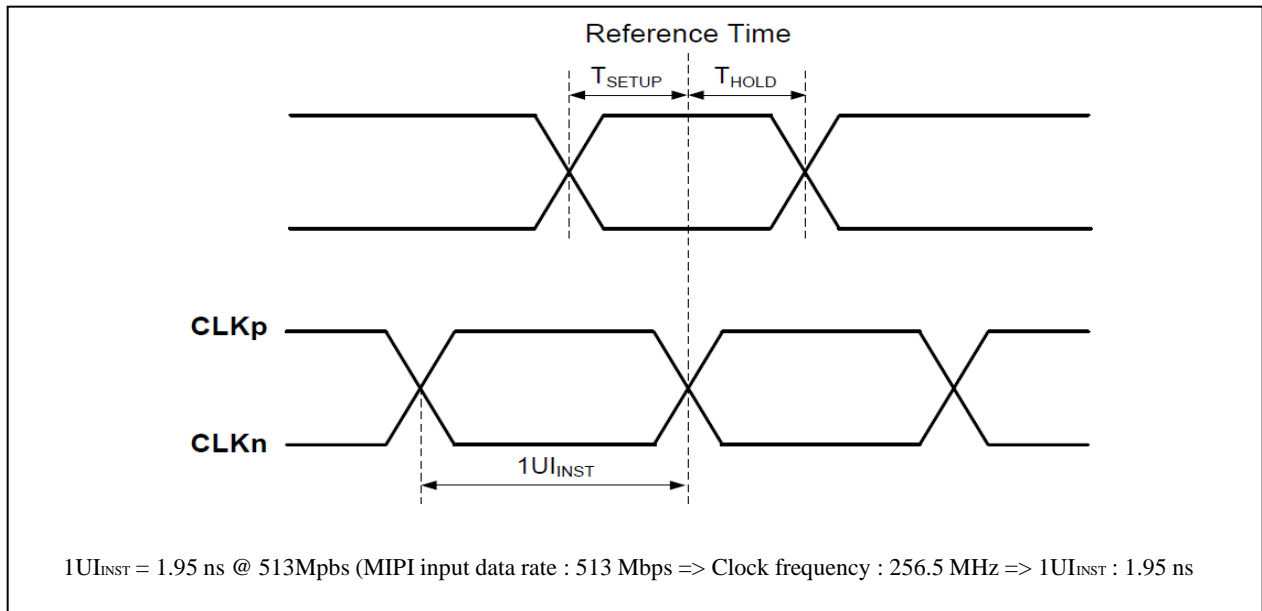

< Timing Diagram of MIPI Transmitter >

Description	Symbol	Condition	Min	Typ	Max	Unit
Data to Clock Setup Time	T_{SETUP}	-	0.15	-	-	UI_{INST}
Clock to Data Hold Time	T_{HOLD}	-	0.15	-	-	UI_{INST}

Product Specification

3-3-3. Data Format

- MIPI Tx Data Configuration

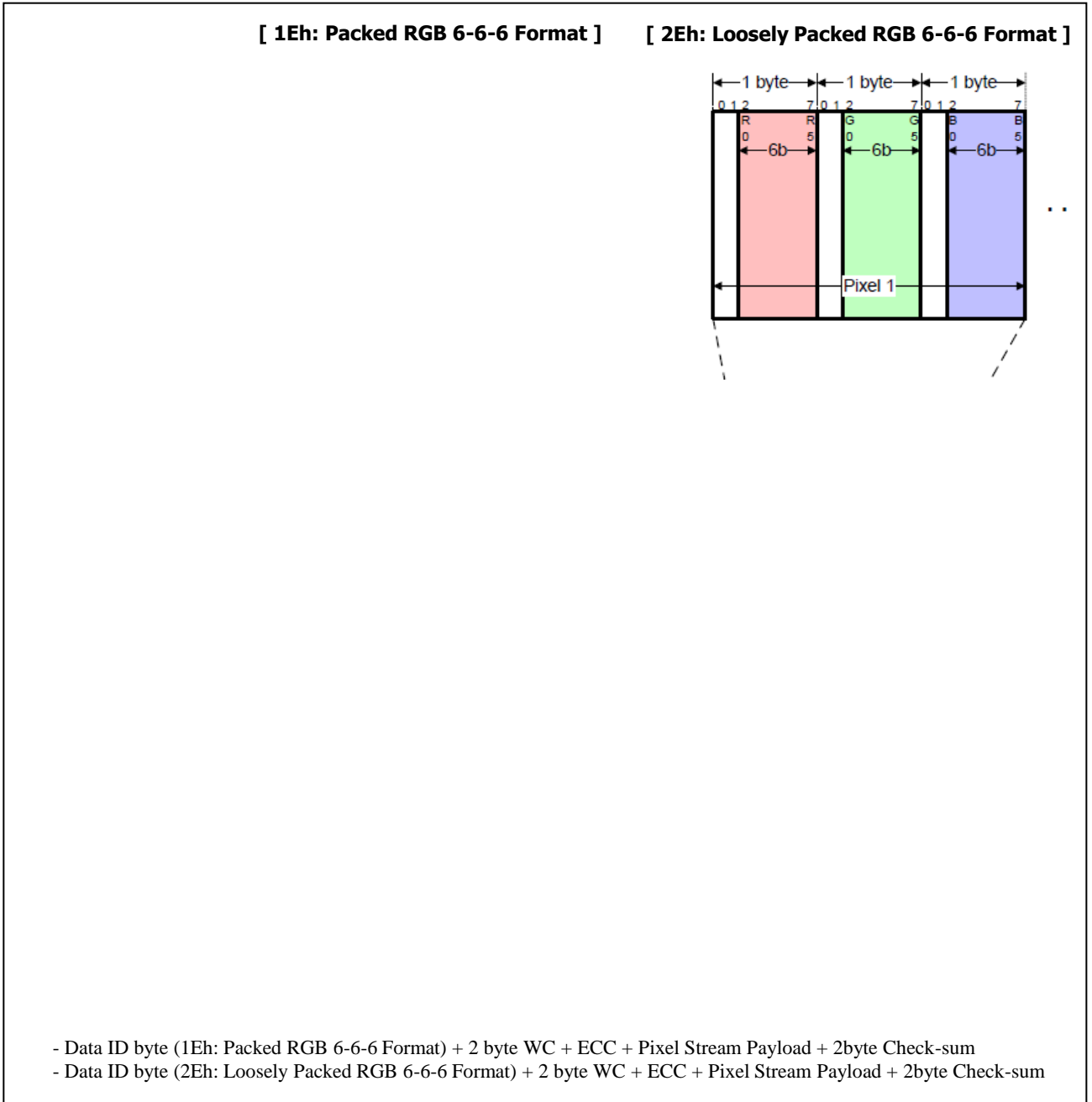

< MIPI Tx Data Configuration >

Product Specification

3-4. Signal Timing Specifications

This is the signal timing required at the input of the User connector. All of the interface signal timing should be satisfied with the following specifications and specifications of MiPi Tx/Rx for its proper operation.

Table 6. TIMING TABLE

ITEM	Symbol	Min.	Typ.	Max.	Unit	Note	
CLK	Frequency	f _{CLK}	-	55.61	-	MHz	MIPI 513Mbps
Hsync	Active	t _{WHA}	768	768	768	t _{CLK}	
	Period	t _{HP}	808	813	823		
	Width-Active	t _{WH}	13	16	19		
Vsync	Active	t _{WVA}	1024	1024	1024	t _{HP}	
	Period	t _{VP}	1070	1140	1210		
	Width-Active	t _{WV}	16	40	66		
Data Enable	Horizontal back porch	t _{HBP}	11	14	18	t _{CLK}	
	Horizontal front porch	t _{HFP}	-	15	18		
	Vertical back porch	t _{VBP}	15	38	60	t _{HP}	
	Vertical front porch	t _{VFP}	15	38	60		

3-5. Signal Timing Waveforms

Condition : VCC = 3.3V

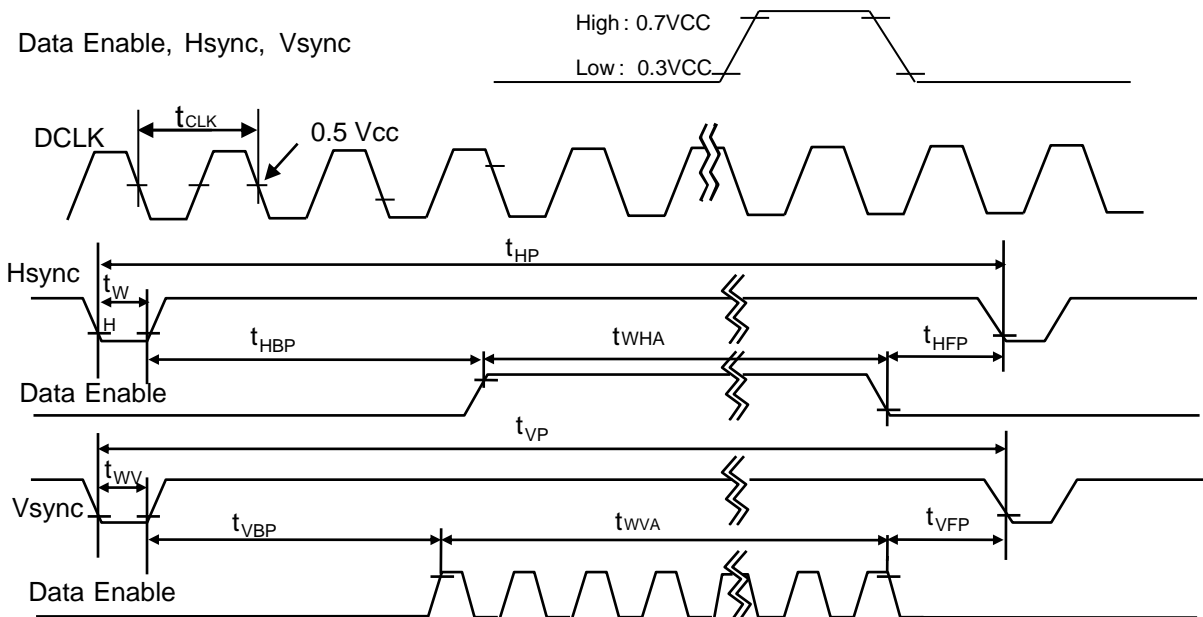

Product Specification

3-6. Color Input Data Reference

The brightness of each primary color (red, green and blue) is based on the 6-bit gray scale data input for the color ; the higher the binary input, the brighter the color. The table below provides a reference for color versus data input.

Table 7. COLOR DATA REFERENCE

Color		Input Color Data																							
		RED						GREEN						BLUE											
		MSB			LSB			MSB			LSB			MSB			LSB								
		R7	R6	R5	R4	R3	R2	R1	R0	G7	G6	G5	G4	G3	G2	G1	G0	B7	B6	B5	B4	B3	B2	B1	B0
Basic Color	Black	0	0	0	0	0	0	0	0	0	0	0	0	0	0	0	0	0	0	0	0	0	0	0	0
	Red (255)	1	1	1	1	1	1	1	1	0	0	0	0	0	0	0	0	0	0	0	0	0	0	0	0
	Green (255)	0	0	0	0	0	0	0	0	1	1	1	1	1	1	1	1	0	0	0	0	0	0	0	0
	Blue (255)	0	0	0	0	0	0	0	0	0	0	0	0	0	0	0	0	1	1	1	1	1	1	1	1
	Cyan	0	0	0	0	0	0	0	0	1	1	1	1	1	1	1	1	1	1	1	1	1	1	1	1
	Magenta	1	1	1	1	1	1	1	1	0	0	0	0	0	0	0	0	1	1	1	1	1	1	1	1
	Yellow	1	1	1	1	1	1	1	1	1	1	1	1	1	1	1	1	0	0	0	0	0	0	0	0
	White	1	1	1	1	1	1	1	1	1	1	1	1	1	1	1	1	1	1	1	1	1	1	1	1
RED	RED (000) Dark	0	0	0	0	0	0	0	0	0	0	0	0	0	0	0	0	0	0	0	0	0	0	0	0
	RED (001)	0	0	0	0	0	0	0	1	0	0	0	0	0	0	0	0	0	0	0	0	0	0	0	0
			
	RED (254)	1	1	1	1	1	1	1	0	0	0	0	0	0	0	0	0	0	0	0	0	0	0	0	0
	RED (255)	1	1	1	1	1	1	1	1	0	0	0	0	0	0	0	0	0	0	0	0	0	0	0	0
GREEN	GREEN (000) Dark	0	0	0	0	0	0	0	0	0	0	0	0	0	0	0	0	0	0	0	0	0	0	0	0
	GREEN (001)	0	0	0	0	0	0	0	0	0	0	0	0	0	0	0	1	0	0	0	0	0	0	0	0
			
	GREEN (254)	0	0	0	0	0	0	0	0	1	1	1	1	1	1	1	0	0	0	0	0	0	0	0	0
	GREEN (255)	0	0	0	0	0	0	0	0	1	1	1	1	1	1	1	1	0	0	0	0	0	0	0	0
BLUE	BLUE (000) Dark	0	0	0	0	0	0	0	0	0	0	0	0	0	0	0	0	0	0	0	0	0	0	0	0
	BLUE (001)	0	0	0	0	0	0	0	0	0	0	0	0	0	0	0	0	0	0	0	0	0	0	0	1
			
	BLUE (254)	0	0	0	0	0	0	0	0	0	0	0	0	0	0	0	0	1	1	1	1	1	1	1	0
	BLUE (255)	0	0	0	0	0	0	0	0	0	0	0	0	0	0	0	0	1	1	1	1	1	1	1	1

Product Specification

3-7. Power Sequence

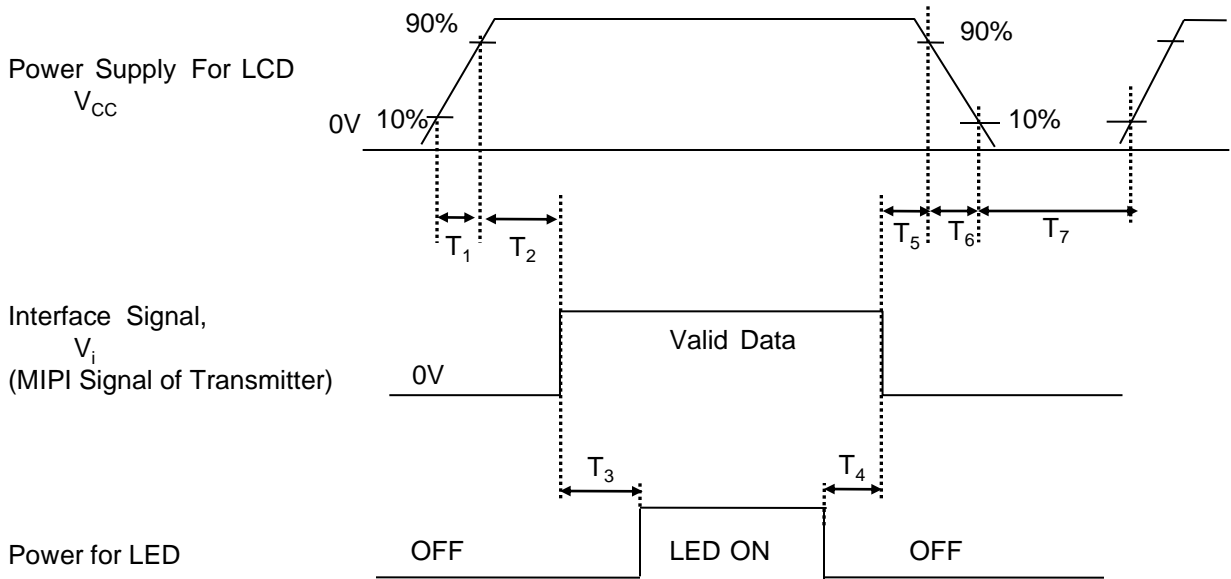

Table 8. POWER SEQUENCE TABLE

Parameter	Value			Units
	Min.	Typ.	Max.	
T1	0.5	-	10	(ms)
T2	177	-	-	(ms)
T3	17	34	-	(ms)
T4	17	-	-	(ms)
T5	100	-	-	(ms)
T6	0	-	20	(ms)
T7	200	-	-	(ms)

Note)

- Valid Data is Data to meet “3-3. MiPi Signal Timing Specifications”
- Please avoid floating state of interface signal at invalid period.
- When the interface signal is invalid, be sure to pull down the power supply for LCD VCC to 0V.
- Lamp power must be turn on after power supply for LCD and interface signal are valid.

Product Specification

4. Optical Specification

Optical characteristics are determined after the unit has been 'ON' and stable for approximately 20 minutes in a dark environment at 25°C. The values specified are at an approximate distance 50cm from the LCD surface at a viewing angle of Φ and Θ equal to 0°.

FIG. 1 presents additional information concerning the measurement equipment and method.

FIG. 1 Optical Characteristic Measurement Equipment and Method

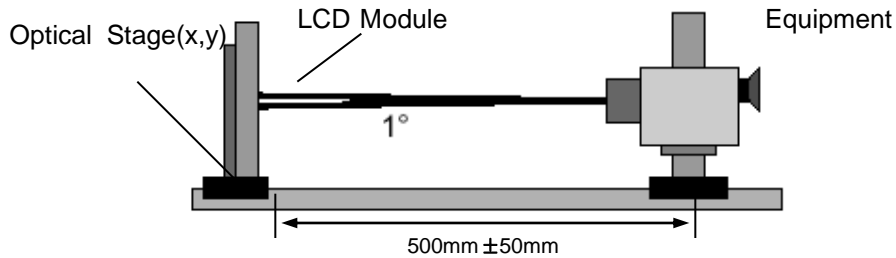
 Table 9. OPTICAL CHARACTERISTICS $T_a=25^\circ\text{C}$, $V_{CC}=3.3\text{V}$, $f_v=60\text{Hz}$, $f_{CLK}=100.03\text{MHz}$, $I_{LED} = 21.8\text{mA}$

Parameter	Symbol	Condition	Min	Typ	Max	Units	Notes	
Average Luminance	LAVE	4 Points (ILED= 21.8mA)	350	425	-	cd/m ²	Fig 2	
Luminance variation	%	96 points	70	85	-	-	Fig 2	
C/R	-	Center 1 Point	500	600	-	-		
Response time		-	-	30	50	ms	Fig 3	
Viewing angle	Horizontal	Θ	$\phi_x(\text{Left,Right})$	± 75	± 80	-	°	Fig 4
	Vertical	Θ	$\phi_{yu}(\text{Up})$	75	80	-		
		Θ	$\phi_{yd}(\text{Down})$	75	80	-		
Cross Talk	DSHA	-	-	-	4.0	%	Fig 5	
Gray Scale	-	-	Gamma 2.2					

Table 10. WRGB Color Chromaticity

	White		Red		Green		Blue	
	Wx	Wy	Rx	Ry	Gx	Gy	Bx	By
1	0.291	0.345	0.623	0.329	0.287	0.595	0.130	0.139
2	0.328	0.345	0.623	0.361	0.367	0.595	0.180	0.139
3	0.328	0.300	0.587	0.361	0.367	0.545	0.180	0.095
4	0.291	0.300	0.587	0.329	0.287	0.545	0.130	0.095
1	0.291	0.345	0.623	0.329	0.287	0.595	0.130	0.139
Typ.	0.309	0.325	0.605	0.345	0.327	0.57	0.155	0.117

Product Specification

Notes)

1. Contrast Ratio(CR) is defined mathematically as

$$\text{Contrast Ratio} = \frac{\text{Surface Luminance with all white pixels}}{\text{Surface Luminance with all black pixels}}$$

2. Response time is the time required for the display to transition from white to black (rise time, Tr_R) and from black to white(Decay Time, Tr_D). For additional information see FIG 3.

3. Viewing angle is the angle at which the contrast ratio is greater than 10. The angles are determined for the horizontal or x axis and the vertical or y axis with respect to the z axis which is normal to the LCD surface. For more information see FIG 4.

4. Gray scale specification

* $f_V=60\text{Hz}$

Gray Level	Luminance [%] (Typ)
L0	0.13
L7	1.00
L15	4.30
L23	9.80
L31	19.2
L39	34.2
L47	53.5
L55	74.5
L63	100

5. Average Luminance

$$L_{4P\text{ ave}} = \text{Average (L44,L45,L52,L53)}$$

where L1 to L96 are the luminance values measured at point #1 to #96.

6. Luminance Uniformity

Luminance Uniformity:

$$U = 100\% - (L_{\text{max}} - L_{\text{min}}) / L_{\text{max}}$$

where, $L_{\text{max}} = \max \{\text{Luminance values at 96 points}\}$,

$L_{\text{min}} = \min \{\text{Luminance values at 96 points}\}$

7. WRGB Chromaticity

Average (44, 45, 52, 53 Points)

Product Specification

FIG. 2 Luminance

<Measuring point for Average Luminance & measuring point for Luminance variation>

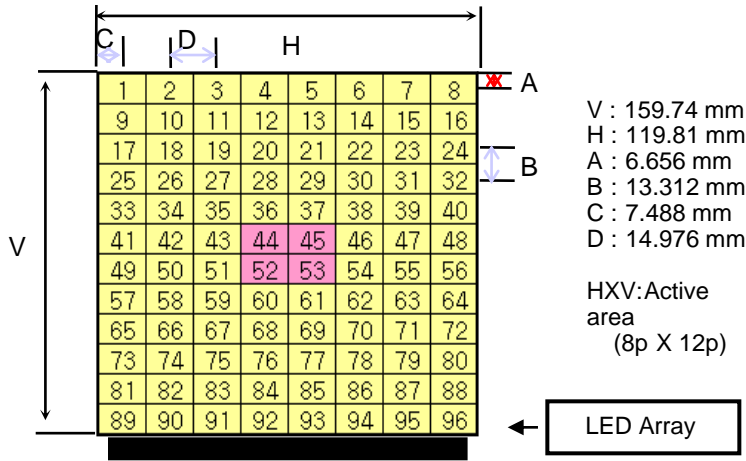

FIG. 3 Response Time

The response time is defined as the following figure and shall be measured by switching the input signal for “black” and “white”.

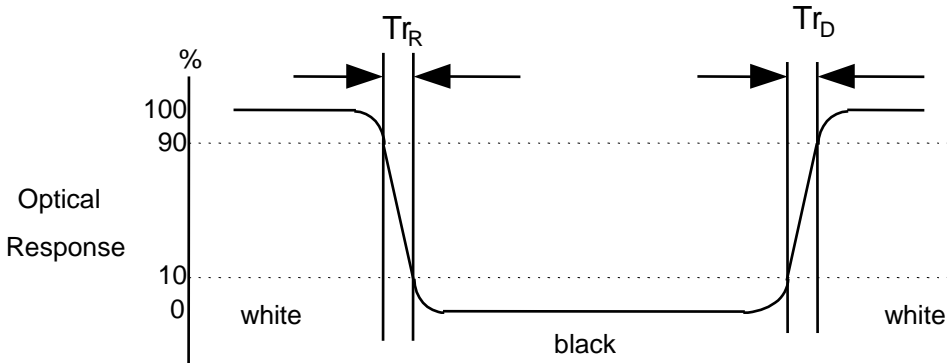
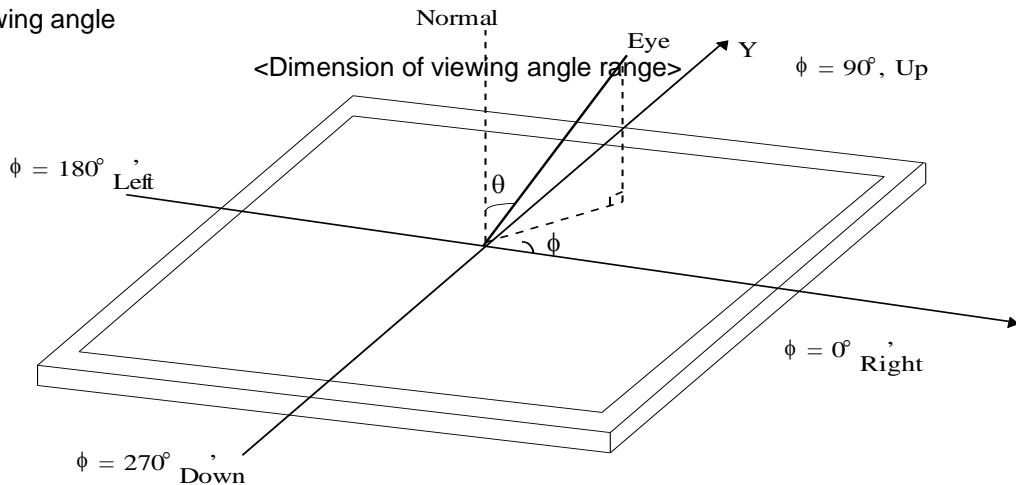

FIG. 4 Viewing angle



Product Specification

FIG. 5 Cross talk

No visual cross-talk will be allowed. Two luminance values are measured at center spot with 50 x 50 pixels. The cross-talk, D_{SHA} , is defined as,

$$D_{SHA} = (L_B - L_A) / L_B \cdot 100\%$$

Where, L_A = Luminance in Pattern A

L_B = Luminance in Pattern B.

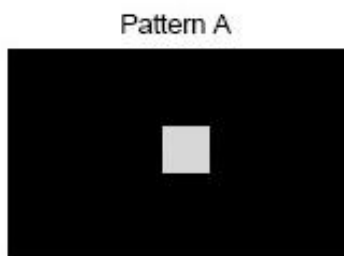

Pattern A
Gray Scale = 31 in center
Black in surrounding area

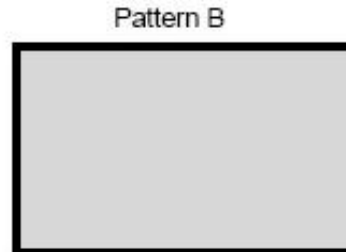

Pattern B
Gray Scale = 31 full screen

5. Mechanical Characteristics

The contents provide general mechanical characteristics for the model LP097X02. In addition the figures in the next page are detailed mechanical drawing of the LCD.

Outline Dimension	Horizontal	210.32 ± 0.20mm
	Vertical	164.37 ± 0.20mm
	Thickness	2.88mm(Max.) ※ PCB area : 5.22(Max.)
Bezel Area	Horizontal	201.01mm(POL)
	Vertical	151.86mm(POL)
Active Display Area	Horizontal	196.608mm
	Vertical	147.456mm
Weight	143g (Max.)	
Surface Treatment	Hard coating(2H), Glare treatment of the front Polarizer (Haze 0%)	

Product Specification

* UNSPECIFIED TOLARENCE IS ± 0.5

Product Specification

6. Reliability

Environment test condition

No.	Test Item	Conditions
1	High temperature storage test	Ta= 60°C, 240h
2	Low temperature storage test	Ta= -20°C, 240h
3	High temperature operation test	Ta= 50°C, 50%RH, 240h
4	Low temperature operation test	Ta= 0°C, 240h
5	Vibration test (non-operating)	Sine wave, 10 ~ 500 ~ 10Hz, 1.5G, 0.37oct/min 3 axis, 1hour/axis
6	Shock test (non-operating)	Half sine wave, 180G, 2ms one shock of each six faces(I.e. run 180G 6ms for all six faces)
7	Altitude operating storage / shipment	0 ~ 10,000 feet (3,048m) 24Hr 0 ~ 40,000 feet (12,192m) 24Hr

{ Result Evaluation Criteria }

There should be no change which might affect the practical display function when the display quality test is conducted under normal operating condition.

7. International Standards

7-1. Safety

- a) UL 60950-1:2003, First Edition, Underwriters Laboratories, Inc., Standard for Safety of Information Technology Equipment.
- b) CAN/CSA C22.2, No. 60950-1-03 1st Ed. April 1, 2003, Canadian Standards Association, Standard for Safety of Information Technology Equipment.
- c) EN 60950-1:2001, First Edition, European Committee for Electrotechnical Standardization(CENELEC) European Standard for Safety of Information Technology Equipment.

7-2. EMC

- a) ANSI C63.4 "Methods of Measurement of Radio-Noise Emissions from Low-Voltage Electrical and Electrical Equipment in the Range of 9kHz to 40GHz." American National Standards Institute(ANSI), 1992
- b) C.I.S.P.R "Limits and Methods of Measurement of Radio Interface Characteristics of Information Technology Equipment." International Special Committee on Radio Interference.
- c) EN 55022 "Limits and Methods of Measurement of Radio Interface Characteristics of Information Technology Equipment." European Committee for Electrotechnical Standardization.(CENELEC), 1998 (Including A1: 2000)

Product Specification

8. Packing

8-1. Designation of Lot Mark

a) Lot Mark

A	B	C	D	E	F	G	H	I	J	K	L	M
---	---	---	---	---	---	---	---	---	---	---	---	---

A,B,C : SIZE(INCH)
E : MONTH

D : YEAR
F ~ M : SERIAL NO.

Note

1. YEAR

Year	2001	2002	2003	2004	2005	2006	2007	2008	2009	2010
Mark	1	2	3	4	5	6	7	8	9	0

2. MONTH

Month	Jan	Feb	Mar	Apr	May	Jun	Jul	Aug	Sep	Oct	Nov	Dec
Mark	1	2	3	4	5	6	7	8	9	A	B	C

b) Location of Lot Mark

Serial No. is printed on the label. The label is attached to the backside of the LCD module.
This is subject to change without prior notice.

8-2. Packing Form

a) Package quantity in one box : 40 pcs

b) Box Size : 482mm × 371mm × 330mm

Product Specification

9. PRECAUTIONS

Please pay attention to the followings when you use this TFT LCD module.

9-1. MOUNTING PRECAUTIONS

- (1) You must mount a module using holes arranged in four corners or four sides.
- (2) You should consider the mounting structure so that uneven force (ex. Twisted stress) is not applied to the module. And the case on which a module is mounted should have sufficient strength so that external force is not transmitted directly to the module.
- (3) Please attach the surface transparent protective plate to the surface in order to protect the polarizer. Transparent protective plate should have sufficient strength in order to resist external force.
- (4) You should adopt radiation structure to satisfy the temperature specification.
- (5) Acetic acid type and chlorine type materials for the cover case are not desirable because the former generates corrosive gas of attacking the polarizer at high temperature and the latter causes circuit break by electro-chemical reaction.
- (6) Do not touch, push or rub the exposed polarizers with glass, tweezers or anything harder than HB pencil lead. And please do not rub with dust clothes with chemical treatment. Do not touch the surface of polarizer for bare hand or greasy cloth.(Some cosmetics are detrimental to the polarizer.)
- (7) When the surface becomes dusty, please wipe gently with absorbent cotton or other soft materials like chamois soaks with petroleum benzene. Normal-hexane is recommended for cleaning the adhesives used to attach front / rear polarizers. Do not use acetone, toluene and alcohol because they cause chemical damage to the polarizer.
- (8) Wipe off saliva or water drops as soon as possible. Their long time contact with polarizer causes deformations and color fading.
- (9) Do not open the case because inside circuits do not have sufficient strength.

9-2. OPERATING PRECAUTIONS

- (1) The spike noise causes the mis-operation of circuits. It should be lower than following voltage :
 $V = \pm 200\text{mV}$ (Over and under shoot voltage)
- (2) Response time depends on the temperature.(In lower temperature, it becomes longer.)
- (3) Brightness depends on the temperature. (In lower temperature, it becomes lower.)
And in lower temperature, response time(required time that brightness is stable after turned on) becomes longer.
- (4) Be careful for condensation at sudden temperature change. Condensation makes damage to polarizer or electrical contacted parts. And after fading condensation, smear or spot will occur.
- (5) When fixed patterns are displayed for a long time, remnant image is likely to occur.
- (6) Module has high frequency circuits. Sufficient suppression to the electromagnetic interference shall be done by system manufacturers. Grounding and shielding methods may be important to minimized the interference.

Product Specification

9-3. ELECTROSTATIC DISCHARGE CONTROL

Since a module is composed of electronic circuits, it is not strong to electrostatic discharge. Make certain that treatment persons are connected to ground through wrist band etc. And don't touch interface pin directly.

9-4. PRECAUTIONS FOR STRONG LIGHT EXPOSURE

Strong light exposure causes degradation of polarizer and color filter.

9-5. STORAGE

When storing modules as spares for a long time, the following precautions are necessary.

- (1) Store them in a dark place. Do not expose the module to sunlight or fluorescent light. Keep the temperature between 5°C and 35°C at normal humidity.
- (2) The polarizer surface should not come in contact with any other object.
It is recommended that they be stored in the container in which they were shipped.

9-6. HANDLING PRECAUTIONS FOR PROTECTION FILM

- (1) When the protection film is peeled off, static electricity is generated between the film and polarizer.
This should be peeled off slowly and carefully by people who are electrically grounded and with well ion-blown equipment or in such a condition, etc.
- (2) The protection film is attached to the polarizer with a small amount of glue. If some stress is applied to rub the protection film against the polarizer during the time you peel off the film, the glue is apt to remain on the polarizer.
Please carefully peel off the protection film without rubbing it against the polarizer.
- (3) When the module with protection film attached is stored for a long time, sometimes there remains a very small amount of glue still on the polarizer after the protection film is peeled off.
- (4) You can remove the glue easily. When the glue remains on the polarizer surface or its vestige is recognized, please wipe them off with absorbent cotton waste or other soft material like chamois soaked with normal-hexane.