

Specifications for TFT-LCD Monitor

Version 4.0

MODEL COM50T5123GLC

Customer's Approval
Signature:
Name:
Section:
Title:
Date:

ORTUSTECH

ORTUS TECHNOLOGY CO., LTD.
 Sales Headquarters
 2951-5 Ishikawa-cho, Hachioji-city, Tokyo
 192-8556, Japan
 TEL 81-42-639-5121
 FAX 81-42-639-5034

Approved by
T. Tamura

Checked by



ORTUS TECHNOLOGY CO., LTD.
 Product Quality Assurance
 2951-5 Ishikawa-cho, Hachioji-city, Tokyo
 192-8556, Japan
 TEL 81-42-639-5138
 FAX 81-42-639-5037

Approved by
H. Okimoto

Checked by
K. Sakamoto

Prepared by
M. Jojo

Revision History

Ver.	Date	Page	Description					
1.0	Jun.30,2008		First issue					
2.0	Sep.10,2009  ×24	P.6	3.2 Outward Form Note, Dimension					
		×16						
		P.9	4. PIN ASSIGNMENT					
			Change Comment					
		P.11	7.1.1 Display Module					
			Addition "Pull down resistor value" rating					
			Change "Standby Current"					
			"Other input with constant voltage"					
			→"MODE="VSS",Other input with constant voltage					
		P.41	9.3 LED Circuit					
P.44	11.1 Defective Display and Screen Quality							
	Change Before							
		<table border="1"> <tr> <td>Liner</td> <td>3.0mm<length, 0.08mm<width</td> <td>N=0</td> </tr> <tr> <td></td> <td>length ≤ 3.0mm, width ≤ 0.08mm</td> <td>Ignored</td> </tr> </table>	Liner	3.0mm<length, 0.08mm<width	N=0		length ≤ 3.0mm, width ≤ 0.08mm	Ignored
Liner	3.0mm<length, 0.08mm<width	N=0						
	length ≤ 3.0mm, width ≤ 0.08mm	Ignored						
	After							
		<table border="1"> <tr> <td>Liner</td> <td>3.0mm<length and 0.08mm<width</td> <td>N=0</td> </tr> <tr> <td></td> <td>length ≤ 3.0mm or width ≤ 0.08mm</td> <td>Ignored</td> </tr> </table>	Liner	3.0mm<length and 0.08mm<width	N=0		length ≤ 3.0mm or width ≤ 0.08mm	Ignored
Liner	3.0mm<length and 0.08mm<width	N=0						
	length ≤ 3.0mm or width ≤ 0.08mm	Ignored						
P.46	12. RELIABILITY TEST							
	Change Electrostatic discharge test (Non operation)							
	Change "EIAJ ED-4701 C-111"→"EIAJ ED-4701/300"							
	Change "FPC tension test" " +/- 90-degree"→" - 90-degree"							
	Change "FPC bend test" "+/-180-degree"→"-180-degree"							
P.47	Change "Tension Test Method for FPC cable", "Bend Test Method for FPC cable"							
P.48	13. PACKING SPECIFICATIONS							
	Correction "PP"→"PP Conductive"							
P.49	14.1 Cautions for Handling LCD panels							
	Addition Comment (10)							
3.0	Feb.12,2010  ×2	P.43	10.1 Optical Characteristics					
			White Chromaticity					
		P.50	14.2 Precautions for Handling					
			Comment 6)					
4.0	May.14,2010 	All	Change It is a company name change from CASIO COMPUTER CO., LTD. to ORTUS TECHNOLOGY CO., LTD.					

		Contents	
1.	Application	4
2.	Outline Specifications		
	2.1 Features of the Products	4
	2.2 Display Method	5
3.	Dimensions and Shape		
	3.1 Dimensions	5
	3.2 Outward Form	6
	3.3 Serial Label (S-Label)	7
4.	Pin Assignment	8
5.	Absolute Maximum Rating	10
6.	Recommended Operating Conditions	10
7.	Characteristics		
	7.1 DC Characteristics	11
	7.2 AC Characteristics	13
	7.3 Input Timing	16
	7.4 Driving Timing Chart	17
	7.5 Example of Driving Timing Chart	18
8.	Description of Operation		
	8.1 Power Supply	20
	8.2 Serial Communication	21
	8.3 Display Data Transfer	33
	8.4 Standby (Power Save) Sequence	34
	8.5 Power On Clear (POC)	36
	8.6 Other Functions	38
9.	Circuit		
	9.1 "MODE"="VSS"	39
	9.2 "MODE"="VDD"	40
	9.3 LED Circuit	41
10.	Characteristics		
	10.1 Optical Characteristics	42
	10.2 Temperature Characteristics	43
11.	Criteria of Judgment		
	11.1 Defective Display and Screen Quality	44
	11.2 Screen and Other Appearance	45
12.	Reliability Test	46
13.	Packing Specifications	48
14.	Handling Instruction		
	14.1 Cautions for Handling LCD panels	49
	14.2 Precautions for Handling	50
	14.3 Precautions for Operation	50
	14.4 Storage Condition for Shipping Cartons	51
	14.5 Precautions for Peeling off the Protective film	51 52
APPENDIX			

1. APPLICATION

This Specification is applicable to 12.6cm (5.0 inch) TFT-LCD back-light monitor for non-military use.

- ⊙ ORTUS TECHNOLOGY makes no warranty or assume no liability that use of this Product and/or any information including drawings in this Specification by Purchaser is not infringing any patent or other intellectual property rights owned by third parties, and ORTUS TECHNOLOGY shall not grant to Purchaser any right to use any patent or other intellectual property rights owned by third parties. Since this Specification contains ORTUS TECHNOLOGY'S confidential information and copy right, Purchaser shall use them with high degree of care to prevent any unauthorized use, disclosure, duplication, publication or dissemination of ORTUS TECHNOLOGY'S confidential information and copy right.
- ⊙ If Purchaser intends to use this Products for an application which requires higher level of reliability and/or safety in functionality and/or accuracy such as transport equipment (aircraft, train automobile etc.), disaster-prevention/security equipment or various safety equipment, Purchaser shall consult ORTUS TECHNOLOGY on such use in advance.
- ⊙ This Product shall not be used for application which requires extremely higher level of reliability and/or safety such as aerospace equipment, telecommunication equipment for trunk lines, control equipment for nuclear facilities or life-support medical equipment.
- ⊙ ORTUS TECHNOLOGY assumes no liability for any damage resulting from misuse, abuse, and/or miss-operation of the Product deviating from the operating conditions and precautions described in the Specification.
- ⊙ If any issue arises as to information provided in this Specification or any other information, ORTUS TECHNOLOGY and Purchaser shall discuss them in good faith and seek solution.
- ⊙ ORTUS TECHNOLOGY assumes no liability for defects such as electrostatic discharge failure occurred during peeling off the protective film or Purchaser's assembly process.
- ⊙ This Product is compatible for RoHS directive.

Object substance	Maximum content [ppm]
Cadmium and its compound	100
Hexavalent Chromium Compound	1000
Lead & Lead compound	1000
Mercury & Mercury compound	1000
Polybrominated biphenyl series (PBB series)	1000
Polybrominated biphenyl ether series (PBDE series)	1000

2. Outline Specifications

2.1 Features of the Product

- 5.0 inch diagonal display, 960 [H] x 240 [V] dots.
- Two kinds of input specifications can be selected.
 - "MODE" = "VSS"
 - 8-bit / 16,777,216 colors.
 - Various display controls and functional selection by 3-wire serial communication method.
 - "MODE" = "VDD"
 - 6-bit / 262,144 colors.
 - Various display controls and functional selection by terminal control.
- 3V voltage single power source.
- Timing generator (TG), Counter-electrode driving circuitry, Built-in power supply circuit
- Power save (Standby) mode capable.
- Built-in rush current reduction circuit
- Built-in panel residual charge reduction circuit
- Long life & high brightness LED back-light monitor.

2.2 Display Method

Items	Specifications	Remarks
Display type	TN type 262,144 colors or 16,777,216 colors Transmissive type, Normally white	
Driving method	a-Si TFT Active matrix Line-scanning, Non-interlace	
Dot arrangement	RGB stripe arrangement	Refer to fig. 1
Signal input method	6-bit or 8-bit RGB, parallel input	
Backlight type	High bright white LED	
Viewing direction	Downward	Normal display orientation

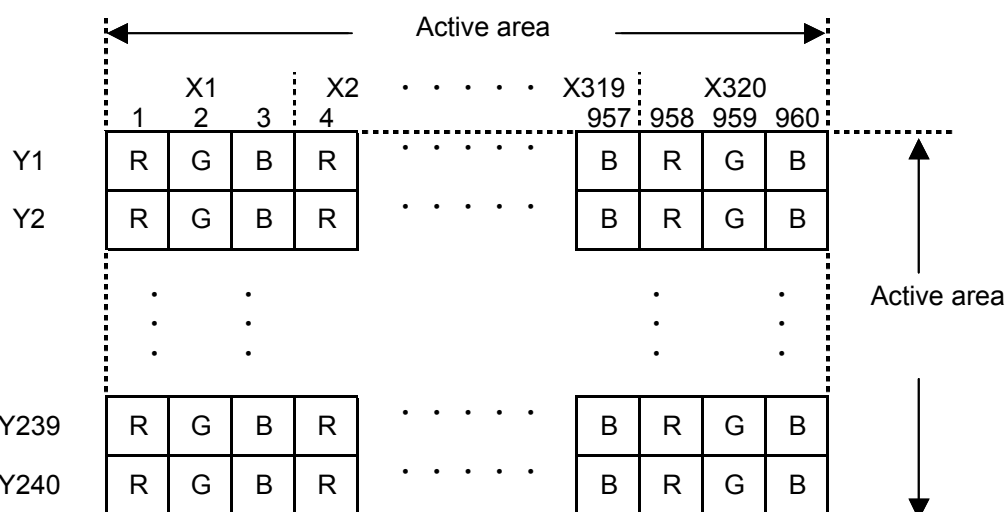

Fig 1 Dot arrangement
(FPC cable placed down)

3. DIMENSIONS AND SHAPE

3.1 Dimensions

Items	Specifications	Unit	Remarks
Outline dimensions	108.30[H] × 87.55[V] × 3.00[D]	mm	Exclude FPC cable
Active area	100.80[H] × 75.60[V]	mm	12.6cm diagonal
Number of dots	960[H] × 240[V]	dot	
Dot pitch	105.0[H] × 315.0[V]	μm	
Surface hardness of the polarizer	3	H	Load: 2.0N
Weight	60.5	g	Include FPC cable

3.2 Outward Form

(6/54)
08TLM067
Issue: May.14,2010

EC No.	REV.No.	REVISE	DATE (Y:M:D)	APPROVED	CHECKED	PREPARED
	△ x 1 6	Change of Note 4. Addition of dimension.	09:09:03	Hashizume	Hiranobu	Fujiwara

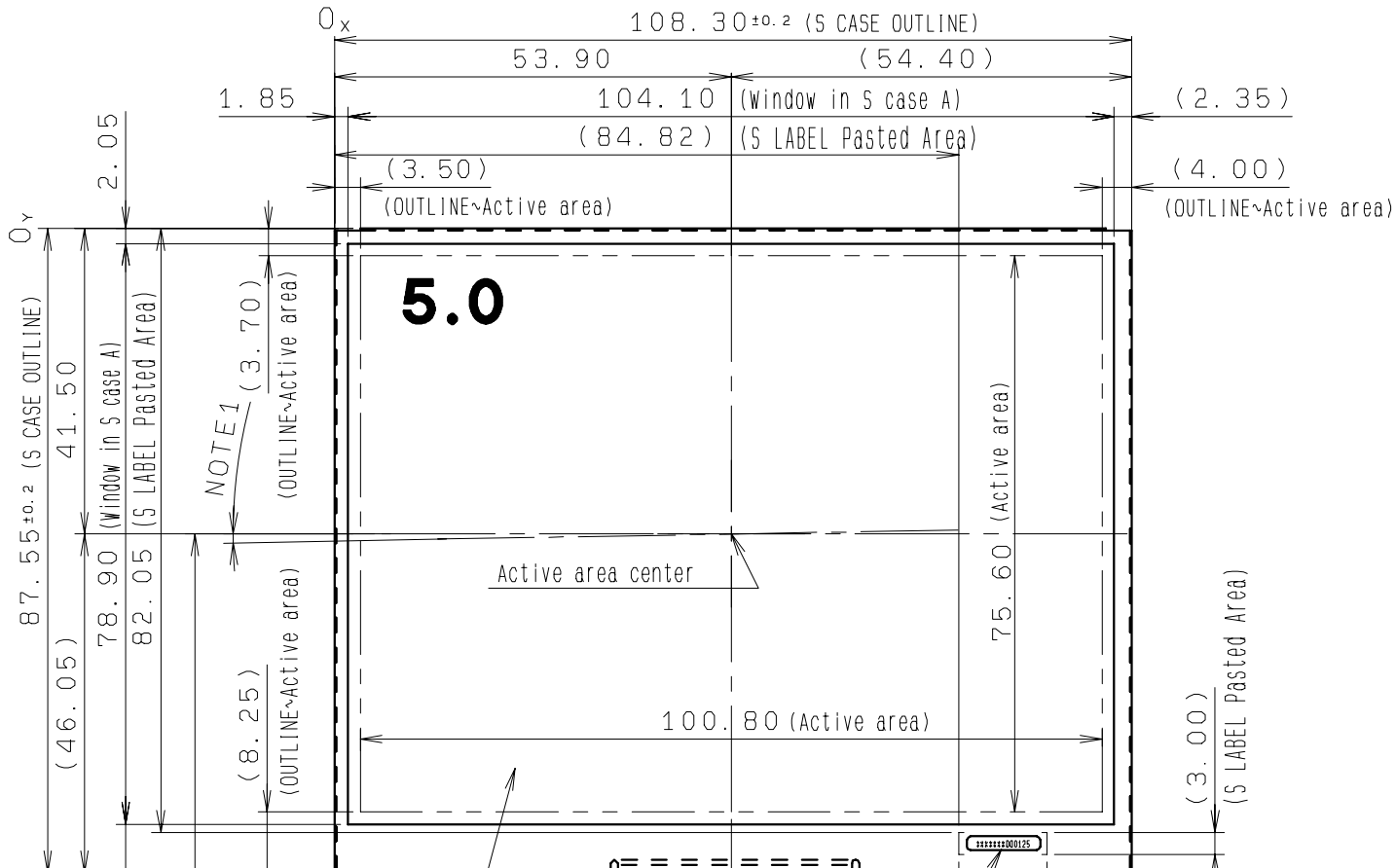

5.0

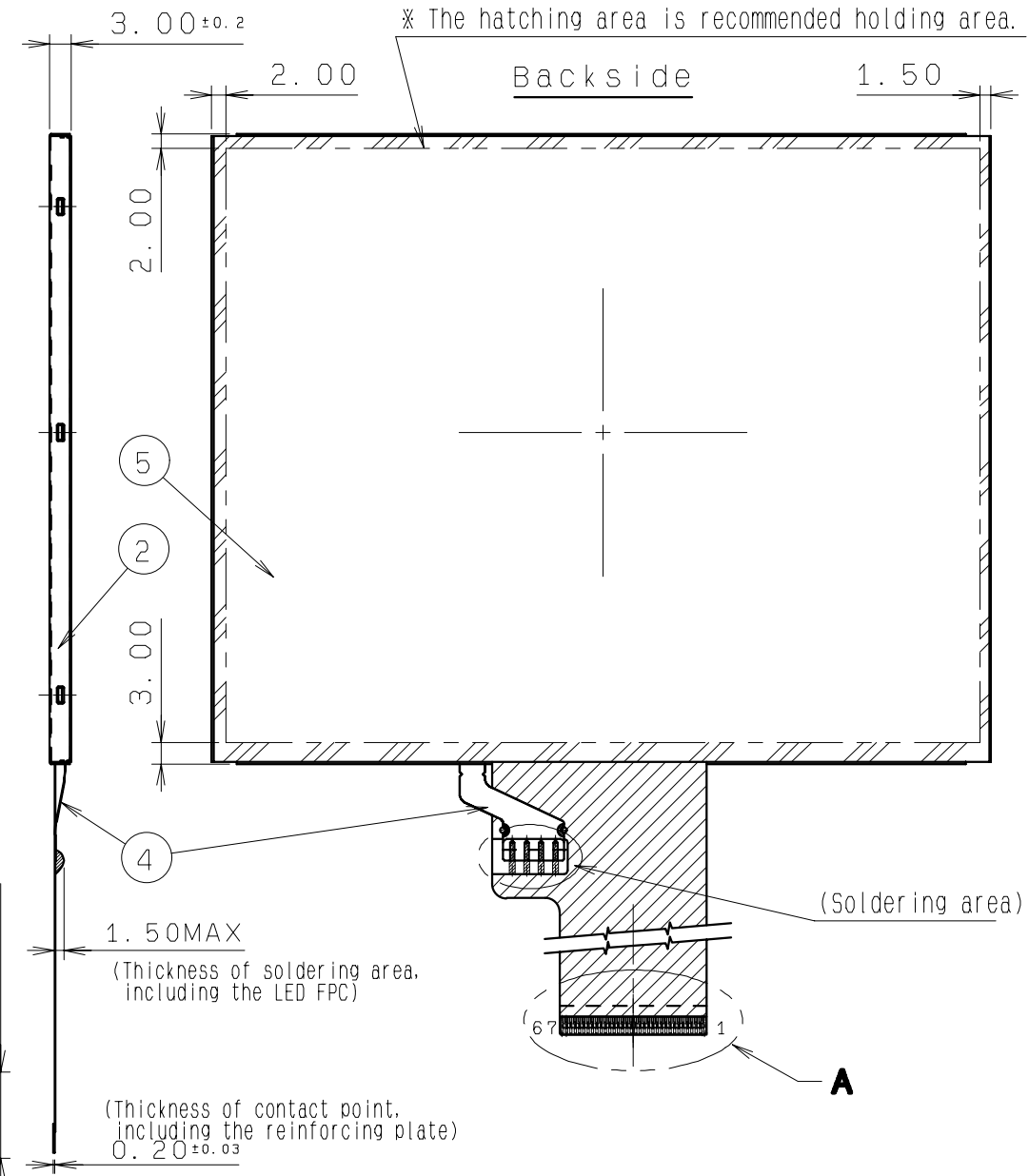
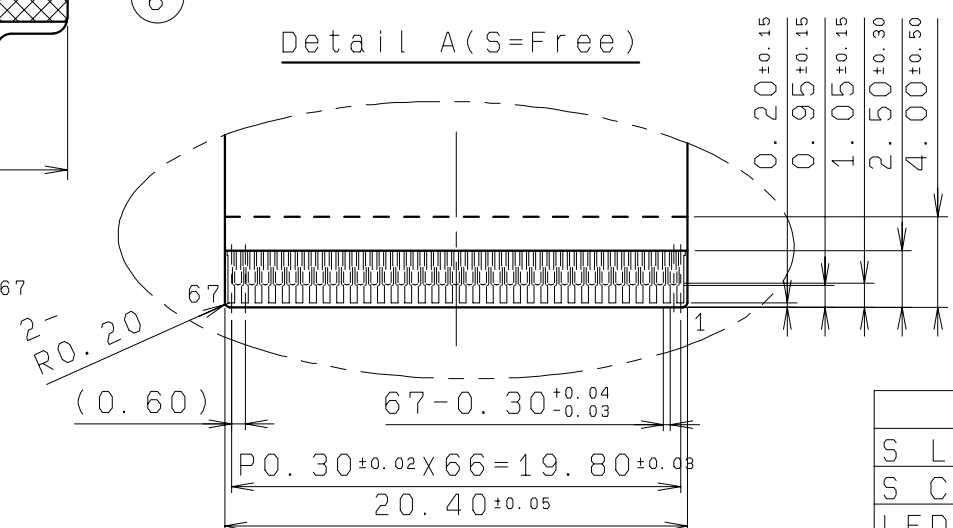
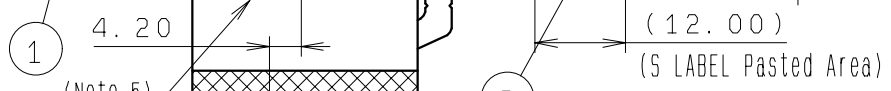

- Note 1. Angular deviation of LCD cell from the TFT-LCD monitor's reference axis shall be less than $\pm 40'$.
- Note 2. S label is affixed the area shown in the drawing. The thickness of the S label will be added to that of S case's surface.
- Note 3. Protective film is affixed on front surface of the screen. Location tolerance of the protective film shall be ± 1.5 mm to the polarizing film.
- Note 4. Recommended FPC connectors
For LCD : KYOCERA ELCO, part number: 04 6281 267 2X2 846+(Lower contact)
: HIROSE, part number: FH26G-67S-0.3SHBW(05)(Lower contact)
FPC pin assignment differs from a position of Datum Pin of recommended FPC connector. Please notice the difference when designing your circuit with much care.
- Note 5. Exercise care not to apply any forces to the cable holder of the S case A.
- Note 6. Refer to "11.CRITERIA OF JUDGMENT" about the appearance specification of a polarizer.

	7			
S LABEL	6			(10x1.85x0.075t)
S CASE C	5			
LED FPC	4			
LCD FPC	3			
S CASE A	2			
LCD	1			Glass substrate thickness=0.5t
PART NAME	ITEM	PART CODE	MATERIAL GRADE	REMARK

APPROVED Hashizume	GENERAL TOLERANCE ± 0.5	SCALE 1/1 (Free)	UNIT mm
CHECKED Hiranobu	ISSUE (Y:M:D) 08:05:12	MODEL DX-5123	
CHECKED	NAME		
DESIGN Yanai	OUTLINE-D5123		
DRAW Yanai			

ORTUSTECH
ORTUS TECHNOLOGY CO., LTD.

DO NOT DUPLICATE, CONFIDENTIAL AND PROPRIETARY

DRAWING No.	REV.	SHEET	DIV.
RJD516644D301			

3.3 SERIAL LABEL (S-LABEL)

1) Display Items

S-label indicates the least significant digit of manufacture year (1digit), manufacture month with below alphabet (1letter), model code (4characters), serial number (6digits).

* Contents of Display

* * **** *****
 _ _ _ _
 a b c d

Contents of display				
a	The least significant digit of manufacture year			
b	Manufacture month	Jan-A Feb-B Mar-C Apr-D	May-E Jun-F Jul-G Aug-H	Sep-I Oct-J Nov-K Dec-L
c	Model code	50KC (Made in Japan) 50LC (Made in China) 50MC (Made in Malaysia)		
d	Serial number			

* Example of indication of Serial label (S-label)

•Made in Japan

8K50KC000125

means "manufactured in Japan in November 2008, model 50K, C specifications, serial number 000125"

•Made in China

8K50LC000125

means "manufactured in China in November 2008, model 50L, C specifications, serial number 000125"

•Made in Malaysia

8K50MC000125

means "manufactured in Malaysia in November 2008, model 50M, C specifications, serial number 000125"

2) Location of Serial Label (S-label)

Refer to 3.2 "Outward Form".

4. PIN ASSIGNMENT

No.	Symbol	Function	
		MODE(No.34pin) = "VSS"	MODE(No.34pin) = "VDD"
1	VCOM	Common-electrode driving signal	
2	D27	Display data input for (B) 00h for black display D20:LSB D27:MSB Driver IC carries out gamma conversion internally.	Display data input for (B) 00h for black display D22:LSB D27:MSB Driver IC carries out gamma conversion internally.
3	D26		
4	D25		
5	D24		
6	D23		
7	D22		
8	D21		
9	D20	Short to VSS	
10	D17	Display data input for (G) 00h for black display D10:LSB D17:MSB Driver IC carries out gamma conversion internally.	Display data input for (G) 00h for black display D12:LSB D17:MSB Driver IC carries out gamma conversion internally.
11	D16		
12	D15		
13	D14		
14	D13		
15	D12		
16	D11		
17	D10	Short to VSS	
18	D07	Display data input for (R) 00h for black display D00:LSB D07:MSB Driver IC carries out gamma conversion internally.	Display data input for (R) 00h for black display D02:LSB D07:MSB Driver IC carries out gamma conversion internally.
19	D06		
20	D05		
21	D04		
22	D03		
23	D02		
24	D01		
25	D00	Short to VSS	
26	BLON	Logic signal output for external backlight circuitry	OPEN
27	CS/STBY	CS:Chip select input for serial communication (Lo: active)	STBY:Stanby signal (Lo:Normal operation, Hi:Stanby operation)
28	DI/DE	DI:Data input for serial communication	DE:Input data effective signal
29	SCK/REV	SCK:Clock input for serial communication	REV:Right/Left & Up/Down Display reverse (Lo:Normal Display,Hi:Reverse Display)
30	VSYNC	Vertical sync signal input	Vertical sync signal input(negative polarity)
31	HSYNC	Horizontal sync signal input	Horizontal sync signal input(negative polarity)
32	CLK	Clock input for display	Clock input for display (DATA sampling at the CLK falling edge)
33	VSS	GND	
34	MODE	Input specification selection input	
35	POCB	Power on clear (Lo: active)	
36	NC	OPEN	
37	RVDD	Internal power supply	
38	COMDC	Common-electrode drive DC output	
39	NC	OPEN	
40	VSREF	Built-in DAC reference supply	
41	C1P	Contacting terminal of capacitor for charge pump	
42	C1M	Contacting terminal of capacitor for charge pump	
43	C2M	Contacting terminal of capacitor for charge pump	
44	C2P	Contacting terminal of capacitor for charge pump	
45	VDD	Power supply input	

No.	Symbol	Function
46	COMOUT	Square wave output for common-electrode
47	VDD2	Internal power supply
48	VSS	GND
49	VSS	GND
50	VSS	GND
51	C3M	Contacting terminal of capacitor for charge pump
52	C3P	Contacting terminal of capacitor for charge pump
53	C4M	Contacting terminal of capacitor for charge pump
54	C4P	Contacting terminal of capacitor for charge pump
55	VVCOM	Voltage output for COMOUT
56	NC	OPEN
57	NC	OPEN
58	VGH	Positive supply for gate driver
59	C5P	Contacting terminal of capacitor for charge pump
60	C5M	Contacting terminal of capacitor for charge pump
61	VGL	Negative supply for gate driver
62	BLL2	LED drive power source 2 (Cathode side)
63	BLH2	LED drive power source 2 (Anode side)
64	NC	OPEN
65	NC	OPEN
66	BLH1	LED drive power source 1 (Anode side)
67	BLL1	LED drive power source 1 (Cathode side)

- Recommended connector: KYOCERA ELCO 6281 series [04 6281 267 2x2 846+]
: HIROSE ELECTRIC FH26 series [FH26G-67S-0.3SHBW(05)]
- Please make sure to check a consistency between pin assignment in "3.2 Outward Form" and your connector pin assignment when designing your circuit.
Inconsistency in input signal assignment may cause a malfunction.
- Since FPC cable has gold plated terminals, gilt finish contact shoe connector is recommended.

5. ABSOLUTE MAXIMUM RATING

VSS=0V

Item	Symbol	Condition	Rating		Unit	Applicable terminal
			MIN	MAX		
Supply voltage	VDD	Ta=25°C	-0.3	6.0	V	VDD
Input voltage 1 for logic	VI1		-0.3	VDD+0.3	V	POCB,CLK,VSYN,HSYN, D[27:00],MODE
Input voltage 2 for logic	VI2		-0.3	6.0	V	CS/STBY,DI/DE,SCK/REV
LED forward current	IL	Ta = 25°C	-	35	mA	BLH1 - BLL1 BLH2 - BLL2
		Ta = 70°C	-	15		
Storage temperature range	Tstg		-30	80	°C	
Storage humidity range	Hstg		Non condensing in an environmental moisture at or less than 40°C90%RH		%	

Note: Please set "Power-on" and "Power-off" sequences in accordance with the "standby sequence" described later.

6. RECOMMENDED OPERATING CONDITIONS

VSS=0V

Item	Symbol	Condition	Rating			Unit	Applicable terminal
			MIN	TYP	MAX		
Supply voltage	VDD		2.7	3.0	3.6	V	VDD
Input voltage 1 for logic	VI1	VDD=2.7~3.6V	0	-	VDD	V	POCB,CLK,VSYN, HSYN, D[27:00] MODE
Input voltage 2 for logic	VI2		0	-	5.5	V	CS/STBY,DI/DE SCK/REV
Common-electrode center voltage Note1	VCOMDC	MODE="VSS" VCOMDC[5:0] =08h~3Ah	1.20	1.70	2.20	V	COMDC
		MODE="VDD"	1.20	1.70	2.20	V	
Operational temperature Note3 range	Top	Note2	-20	+25	+70	°C	Surface of panel
Operating humidity range	Hop	Ta ≤ 30°C	20	-	80	%	
		Ta > 30°C	Non condensing in an environmental moisture at or less than 30°C80%RH.				

Note 1: Common-electrode center voltage indicates that optimum VCOMDC value lies within the bound of these voltages, but it does not mean that the whole range of voltages are the optimum VCOMDC value. This product must to be used with optimized VCOMDC value.

Note 2: This monitor is operable in this temperature range. With regard to optical characteristics, refer to Item 10."CHARACTERISTICS".

Note 3: Acceptable Forward Current to LED is up to 15mA, when Ta=+70°C.
Do not exceed Allowable Forward Current shown on the chart below.

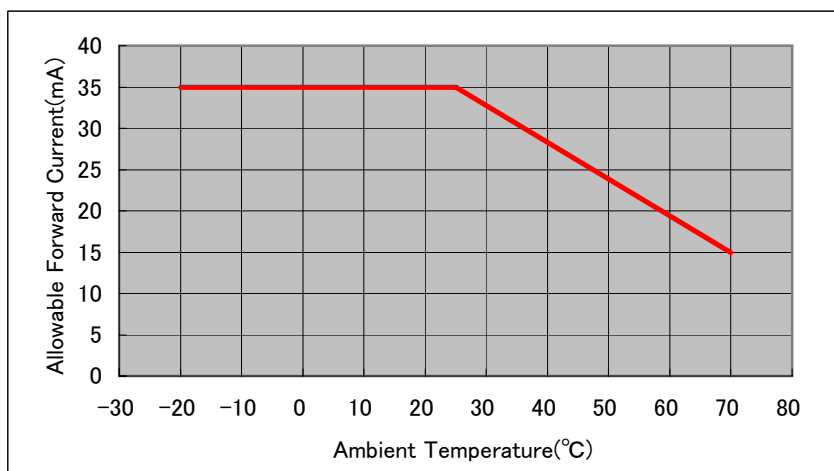

7. CHARACTERISTICS

7.1 DC characteristics

7.1.1 Display Module

(Unless otherwise noted, Ta=25°C, VDD=3.0V, VSS=0V)

Item	Symbol	Condition	Rating			Unit	Applicable terminal
			MIN	TYP	MAX		
Schmitt Threshold voltage	VP	VDD=2.7~3.6V	0.47×VDD	0.60×VDD	0.73×VDD	V	CS/STBY,DI/DE SCK/REV,VSYNC HSYNC,D[27:00] CLK,POCB
	VN		0.30×VDD	0.43×VDD	0.56×VDD	V	
	VH		0.08×VDD	0.17×VDD	0.27×VDD	V	
Input Signal Voltage	VIH		0.7×VDD	–	VDD	V	MODE
	VIL		0	–	0.3×VDD	V	
Pull up resistor value	Rpu		45	91	182	kΩ	POCB
Pull down resistor value	Rpd		45	91	182	kΩ	MODE
Output Voltage1	VDD2		4.8	5.6	6.1	V	VDD2
Output Voltage2	VGH		12.5	13.3	13.5	V	VGH
Output Voltage3	VGL		-13.5	-13.3	-12.5	V	VGL
Output Voltage4	VOH	Io = -1.0mA	VDD - 0.5	–	VDD	V	BLON
	VOL	Io = 1.0mA	0	–	0.5	V	
Operating Current	IDD	fCLK=6.75MHz Color bar display BRIGHT[5:0],CONTRAST[3:0] = Initial value	–	9.5	19.0	mA	VDD
Standby Current	IDDs	MODE="VSS",Other input with constant voltage.	–	11.0	30.0	μA	VDD
		MODE="VDD",Other input with constant voltage.	–	44.0	96.0	μA	

At "MODE" = "VSS"

(Unless otherwise noted, Ta=25°C, VDD=3.0V, VSS=0V)

Item	Symbol	Condition	Rating			Unit	Applicable terminal
			MIN	TYP	MAX		
VcomDC Adjusted value	VCOMDC	VCOMDC[5:0]=00h	0.94	1.04	1.14	V	COMDC
		VCOMDC[5:0]=1Fh	1.56	1.66	1.76		
		VCOMDC[5:0]=3Ch	2.14	2.24	2.34		

(Unless otherwise noted, Ta=25°C, VDD=3.0V, VSS=0V)

Item	Symbol	Condition	Rating			Unit	
			MIN	TYP	MAX		
BRIGHT Adjusted value	VLCD	BRIGHT[5:0]=00h	D[*7:*0]=00h	4.10	4.25	4.40	V
		CONTRAST[3:0]=Eh	D[*7:*0]=FFh	0.92	1.07	1.22	
		BRIGHT[5:0]=1Ah	D[*7:*0]=00h	3.58	3.73	3.88	
		CONTRAST[3:0]=Eh	D[*7:*0]=FFh	0.40	0.55	0.70	
		BRIGHT[5:0]=2Eh	D[*7:*0]=00h	3.18	3.33	3.48	
		CONTRAST[3:0]=Eh	D[*7:*0]=FFh	0.00	0.15	0.30	
CONTRAST Adjusted value	VLCD	CONTRAST[3:0]=0h		1.35	1.50	1.65	V
		VLCD(D[*7:*0]=00h)-VLCD(D[*7:*0]=FFh)		3.03	3.18	3.33	
		CONTRAST[3:0]=Eh		3.15	3.30	3.45	
		VLCD(D[*7:*0]=00h)-VLCD(D[*7:*0]=FFh)					

7.1.2 Backlight

Item	Symbol	Condition	Rating			Unit	Applicable terminal
			MIN	TYP	MAX		
Forward current	IL25	Ta=25° C	-	20.0	35.0	mA	BLH1 - BLL1 BLH2 - BLL2
	IL70	Ta=70° C	-	-	15.0	mA	
Forward voltage	VL	Ta=25° C, IL=20.0mA	-	19.2	21.0	V	
Estimated Life of LED	LL	Ta=25° C, IL=20.0mA Note1	-	(50,000)	-	hr	

Note1: - The lifetime of the LED is defined as a period till the brightness of the LED decreases to the half of its initial value.

- This figure is given as a reference purpose only, and not as a guarantee.
- This figure is estimated for an LED operating alone.

As the performance of an LED may differ when assembled as a monitor together with a TFT panel due to different environmental temperature.

- Estimated lifetime could vary on a different temperature and usually higher temperature could reduce the life significantly.

7. 2. AC CHARACTERISTICS

7.2.1 Display Module

(Unless otherwise noted, Ta=25° C, VDD=3.0V, VSS=0V)

Item	Symbol	Condition	Rating			Unit	Applicable terminal
			MIN	TYP	MAX		
CLK Low period	tw1L	0.1×VDD or less	20	-	-	ns	CLK
CLK High period	tw1H	0.9×VDD or more	20	-	-	ns	CLK
Setup time 1	tsp1		10	-	-	ns	CLK,HSYNC,VSYNC
Hold time 1	thd1		10	-	-	ns	D[27:00],DI/DE Note1
Setup time 2	tsp2		2	-	-	CLK	VSYNC,HSYNC
Hold time 2	thd2		2	-	-	CLK	VSYNC,HSYNC
VSYNC pulse width	tw2H		4	-	-	CLK	VSYNC
HSYNC pulse width	tw3H		2CLK	-	20μs		HSYNC
CLK frequency	fCLK		-	6.75	9.0	MHz	CLK

Note1: The Rating value of the terminal DI/DE is effective at "MODE" = "VDD".

Switching Waveform Characteristics

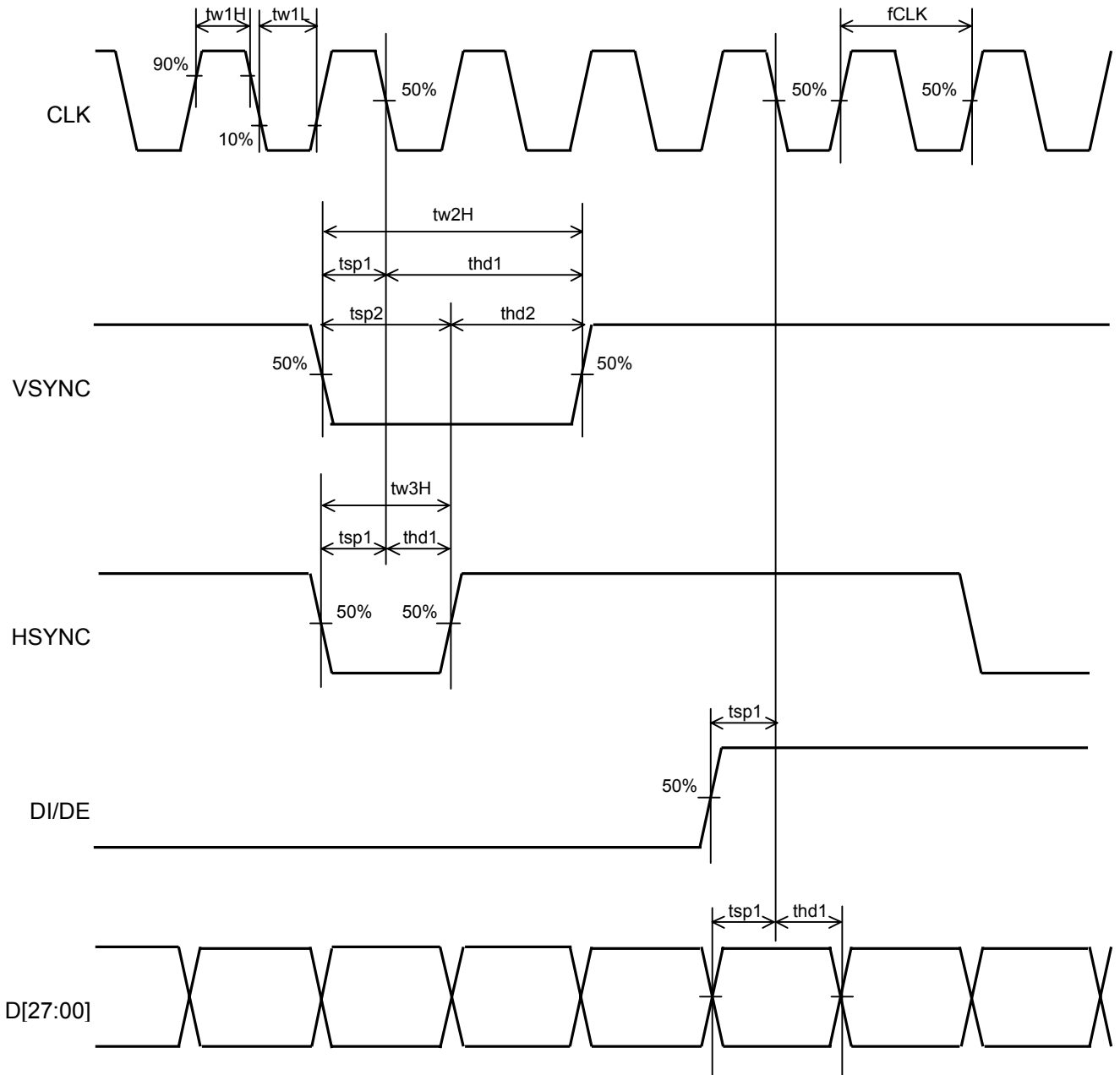

7.2.2 Serial Communication Block

(Unless otherwise noted, $T_a=25^\circ\text{C}$, $V_{DD}=3.0\text{V}$, $V_{SS}=0\text{V}$)

Item	Symbol	Condition	Rating			Unit	Applicable Terminals
			MIN	TYP	MAX		
CS setup time	tsp5		20	—	—	ns	CS/STBY
CS hold time	thd5		20	—	—	ns	CS/STBY
DI setup time	tsp6		20	—	—	ns	DI/DE
DI hold time	thd6		20	—	—	ns	DI/DE
CS pulse High period	tw4H		20	—	—	ns	CS/STBY
SCK pulse Low period	tw5L		20	—	—	ns	SCK/REV
SCK pulse High period	tw5H		20	—	—	ns	SCK/REV

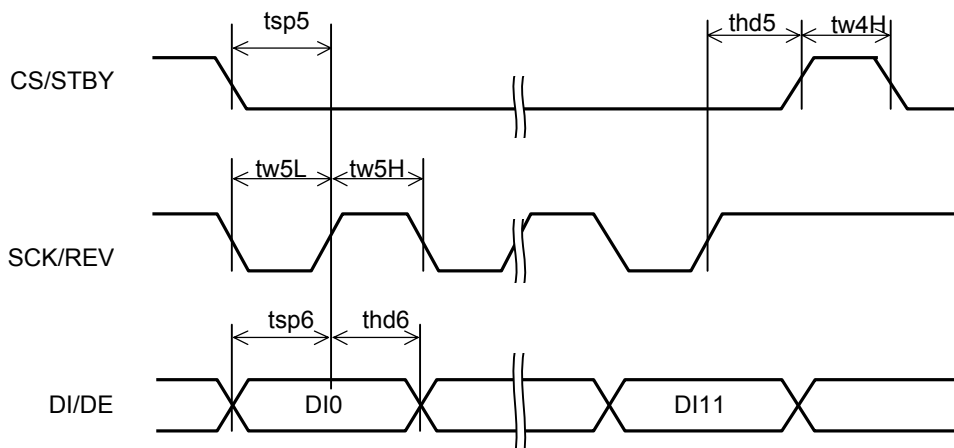

Note: Unless otherwise noted, each item is defined between each 50 % point of signal amplitude.

7.3 INPUT TIMING

7.3.1 MODE = "VSS"

Item	Symbol	Rating			Unit	Applicable terminal
		MIN	TYP	MAX		
CLK frequency	fCLK	—	6.75	9.0	MHz	CLK
VSYNC Frequency Note1	fVSYNC	54	60	66	Hz	VSYNC
Number of Frame Line	tv	—	262	291	H	VSYNC,HSYNC
VSYNC Pulse Width	tw2H	4CLK	3H	—		VSYNC,CLK
Vertical Back Porch	tvb	0 Note2	6	31	H	VSYNC,HSYNC,D[27:00]
Vertical Display Period	tvdp	—	240	—	H	VSYNC,HSYNC,D[27:00]
HSYNC frequency	fHSYNC	—	15.7	—	kHz	HSYNC
HSYNC Cycle	th	—	429	573	CLK	HSYNC,CLK
HSYNC Pulse Width	tw3H	2CLK	—	20μs		HSYNC,CLK
Horizontal Back Porch	thb	5	42	—	CLK	HSYNC,CLK,D[27:00]
Horizontal Display Period	thdp	—	320	—	CLK	D[27:00],CLK

Note1: This is recommended spec to get high quality picture on display. It is customer's risk to use out of this frequency.

Note2: When VDISP=0, please use odd number for the setting of the total number of lines that compose one field.

7.3.2 MODE = "VDD"

Item	Symbol	Rating			Unit	Applicable terminal
		MIN	TYP	MAX		
CLK frequency	fCLK	—	6.75	9.0	MHz	CLK
VSYNC Frequency Note1	fVSYNC	54	60	66	Hz	VSYNC
Number of Frame Line	tv	—	262	291	H	VSYNC,HSYNC
VSYNC Pulse Width	tw2H	4CLK	3H	—		VSYNC,CLK
Vertical Back Porch	tvb	0 Note2	6	21 Note3	H	VSYNC,HSYNC,DE,D[27:02]
Vertical Display Period	tvdp	—	240	—	H	VSYNC,HSYNC,D[27:02]
HSYNC frequency	fHSYNC	—	15.7	—	kHz	HSYNC
HSYNC Cycle	th	—	429	573	CLK	HSYNC,CLK
HSYNC Pulse Width	tw3H	2CLK	—	20μs		HSYNC,CLK
Horizontal Back Porch	thb	5	42	77 Note3	CLK	HSYNC,CLK,DE,D[27:02]
DE Pulse Width	tw4H	—	320	—	CLK	DE,CLK
Horizontal Display Period	thdp	—	320	—	CLK	D[27:02],CLK

Note1: This is recommended spec to get high quality picture on display. It is customer's risk to use out of this frequency.

Note2: When Vertical Back Porch is "0", please use odd number for the setting of the total number of lines that compose one field.

Note3: When DE keeps "Lo" for 21H and 77CLK or longer, start capturing data automatically from "22H and 78CLK".

7.4 Driving Timing Chart

Vertical Timing

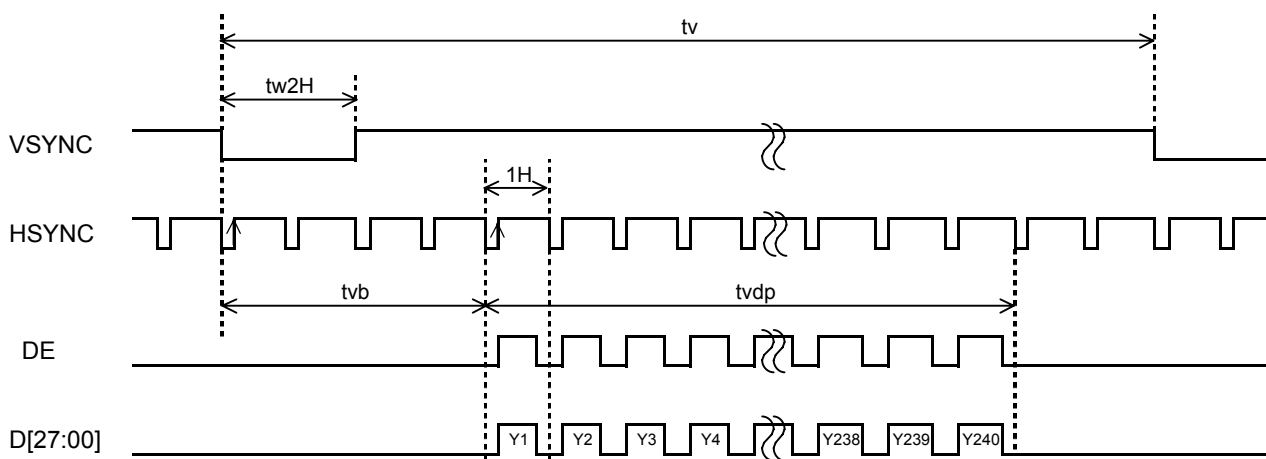

Horizontal Timing

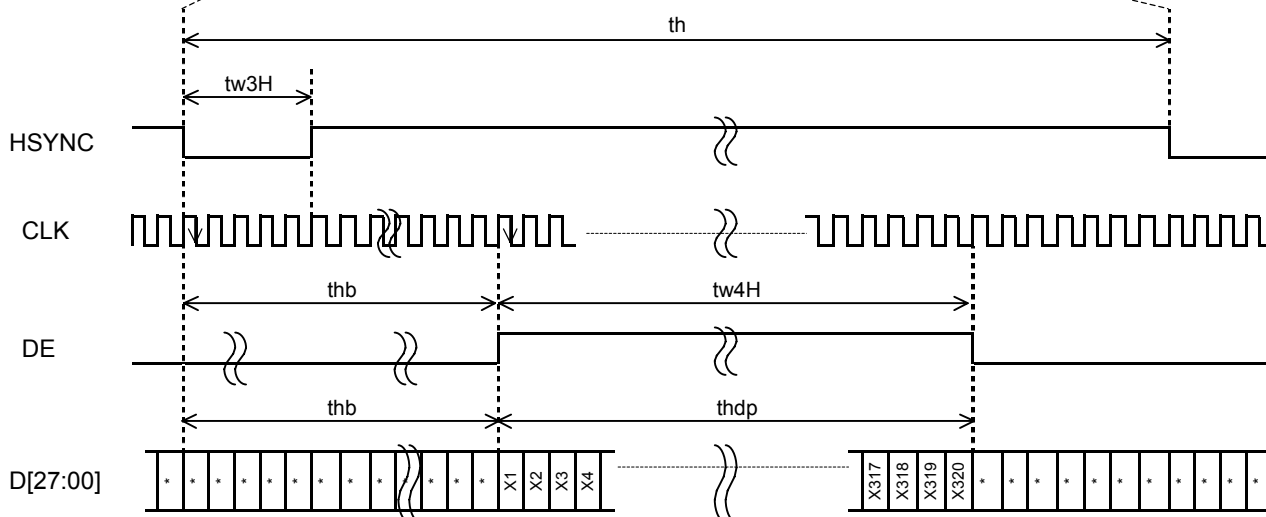

7.5 Example of Driving Timing Chart

7.5.1 MODE = "VSS"(fCLK=6.75MHz)

Vertical Timing

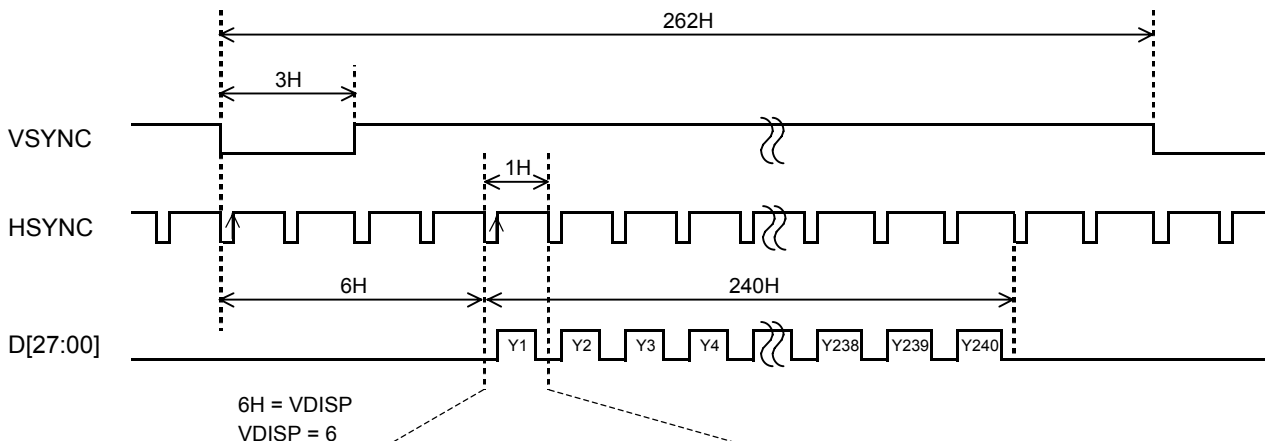

Horizontal Timing

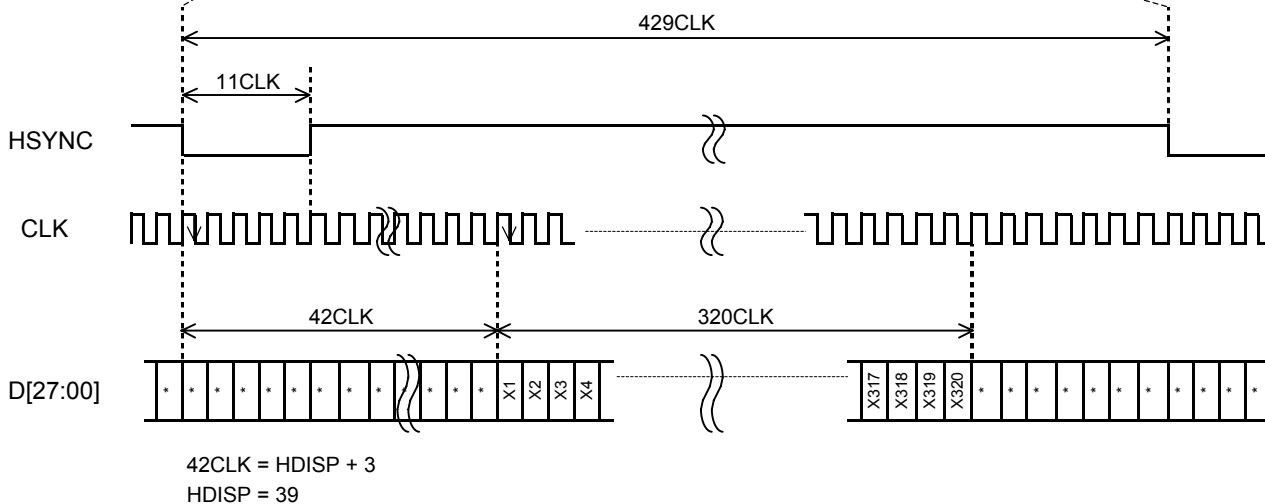

7.3.2 MODE = "VDD"(fCLK=6.75MHz)

Vertical Timing

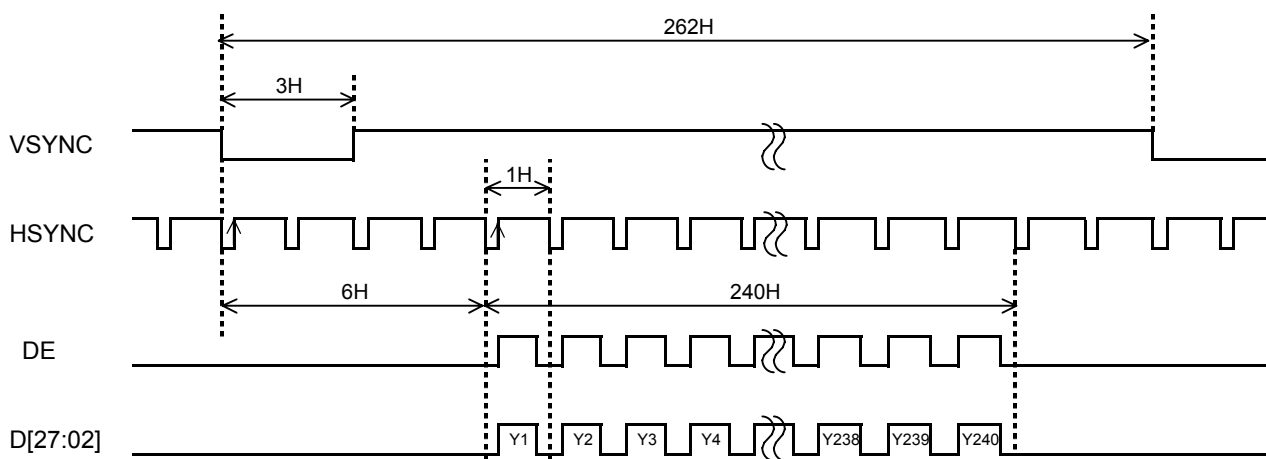

Horizontal Timing

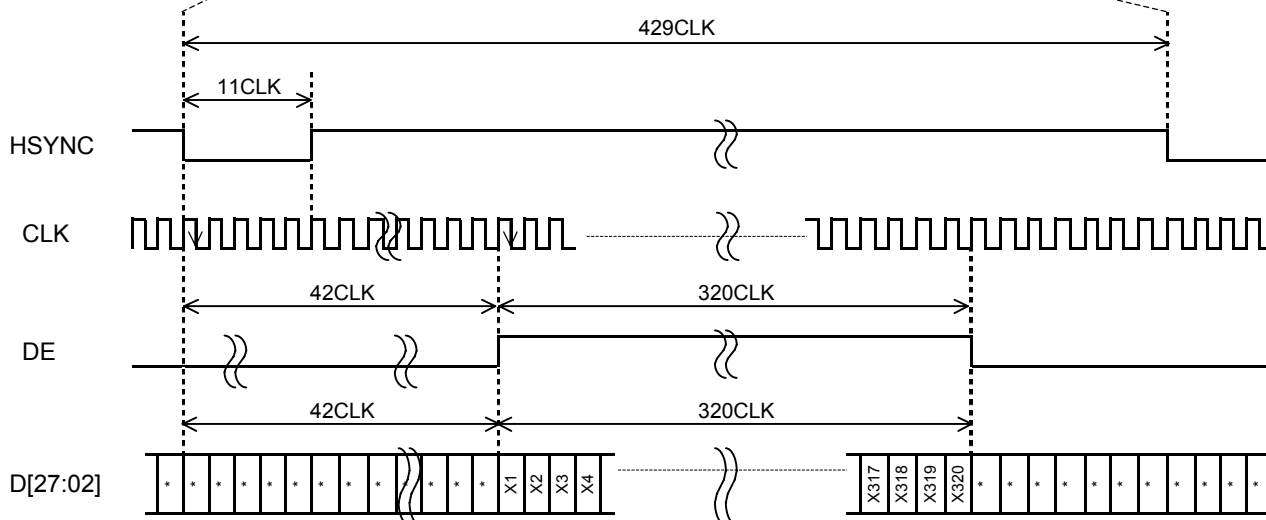

8. DESCRIPTION OF OPERATION

8.1 Power Supply

8.1.1 VDD2 Charge Pump

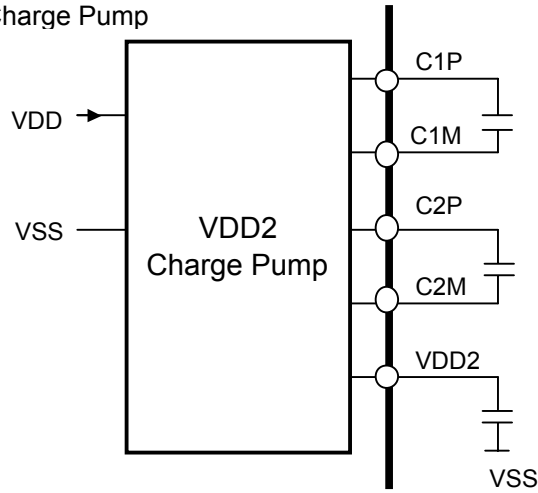

8.1.2 VGH Charge Pump

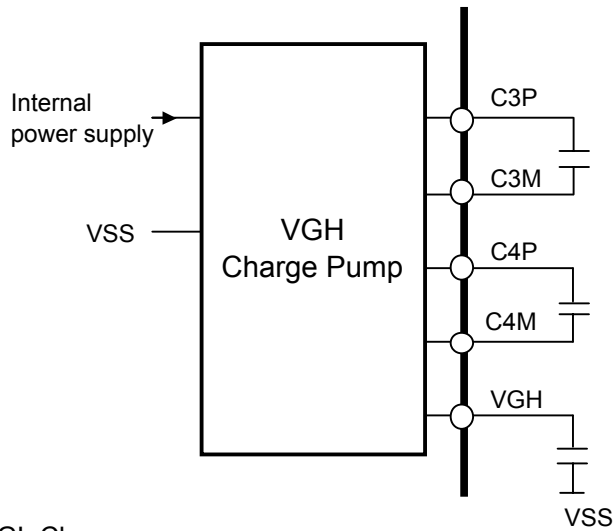

8.1.3 VGL Charge pump

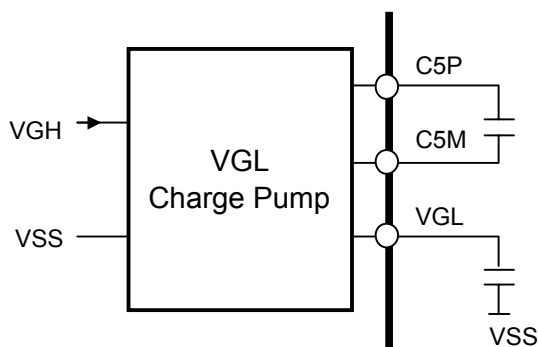

Please use ceramic capacitors with B property for external capacitors

8. 2 Serial Communication

Serial communication control block in the LCD monitor is described below.
Serial communication control function is effective at "MODE" = "VSS".

8. 2. 1 Feature Description

Serial communication control block is consist of registers that store data entered from CS, SCK, DI terminals and DAC that outputs control voltages to each part according to the data loaded from these registers .
All registers are set to initial values at power-on.

Electrostatics or noises may re-set the registers to improper values. It is advisable to set up serial communication as frequently as possible as liquid crystal could degrade if such state is left untreated for a long time.

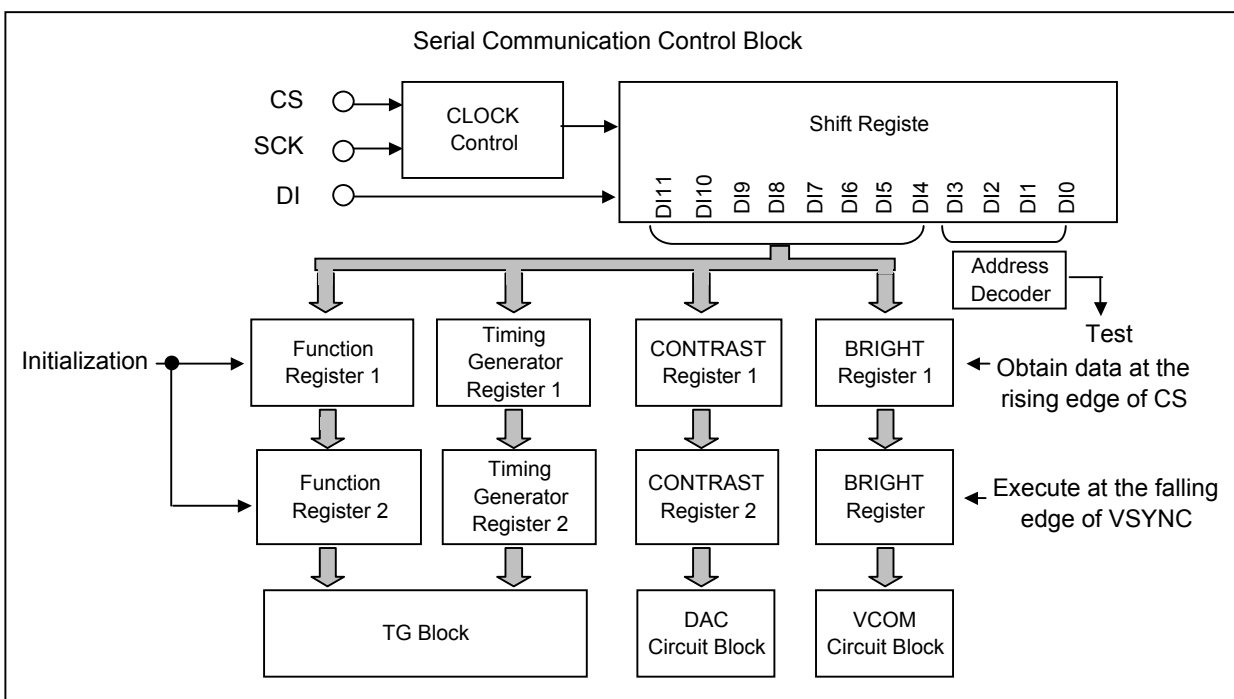

8.2.2 Serial Communication Timing

After input signal of CS drops from Hi to Lo, the Shift Register loads 12 bits of serial data from DI at the rising edge of the input signal of SCK.

Mode register and DAC register load the stored data at the rising edge of the input signal of CS.

When loaded DI data during the low period of CS is less than 12 bits, all loaded data are discarded .

When loaded DI data during the low period of CS is 12 bits or more, the last read of 12 bits is used .

Each command is executed by VSYNC immediately after the rising the edge of CS.

Serial Communication Control Block is configurable at any time during display and standby mode as it is completely independent from other circuitry run by CLK in the monitor.

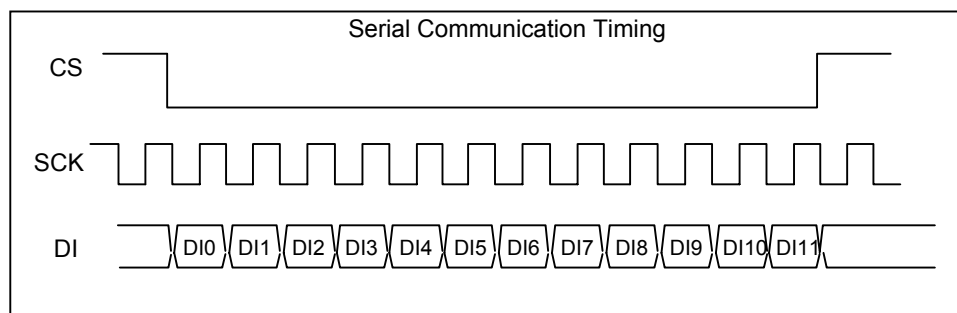

8.2.3 Serial Communication Data

Configuration of serial data for DI terminal

First LSB	DI0	DI1	DI2	DI3	DI4	DI5	DI6	DI7	DI8	DI9	DI10	DI11	Last MSB
Register address					Data								

Register	Address				Number of bits for data	Effect of increase of value	Preset value								User setting value									
	DI0	DI1	DI2	DI3			DI4	DI5	DI6	DI7	DI8	DI9	DI10	DI11	DI4	DI5	DI6	DI7	DI8	DI9	DI10	DI11		
BRIGHT	0	0	0	0	6 (DI6-DI11)	→Brighter	-	-	0	1	0	1	1	0	-	-	User setting							
VCOMDC	1	0	0	0	6 (DI6-DI11)	→higher DC voltage	-	-	1	1	1	1	1	1	-	-	Optimum setting for each monitor							
CONTRAST	0	1	0	0	4 (DI4-DI7)	→higher contrast	0	1	1	1	-	-	-	-	User setting									
PANEL1					3 (DI9-DI11)	-	-	-	-	-	0	0	1	-	-	-	-	-	0	0	1			
VDISP	1	1	0	0	5 (DI4-DI8)	→longer vertical flyback time	1	0	1	0	1	-	-	-	User setting									
PANEL2					2 (DI10-DI11)	-	-	-	-	0	0	0	-	-	-	-	-	0	0	0				
HDISP	0	0	1	0	8 (DI4-DI11)	→longer horizontal flyback time	0	1	0	1	0	0	1	0	User setting									
PANEL3	1	0	1	0	8 (DI4-DI11)	-	0	1	0	0	1	1	0	0	0	1	0	0	1	1	0	0		
FUNC1	0	1	1	0	8 (DI4-DI11)	-	0	0	0	1	0	0	0	0	0	User setting								
FUNC2	1	1	1	0	8 (DI4-DI11)	-	1	1	1	1	0	0	0	0	User setting									
FUNC3	0	0	0	1	8 (DI4-DI11)	-	0	0	0	0	0	0	0	0	0	User setting								
FUNC4	1	0	0	1	8 (DI4-DI11)	-	1	0	0	0	0	0	0	0	1	User setting								
PANEL4	0	1	0	1	8 (DI4-DI11)	-	0	0	0	0	0	0	0	0	0	0	0	0	0	0	0	0		
PANEL5	1	1	0	1	8 (DI4-DI11)	-	0	0	0	0	0	0	0	0	0	1	0	0	0	0	0	0		
PANEL6	0	0	1	1	8 (DI4-DI11)	-	0	0	0	0	0	0	0	0	0	0	0	0	0	0	0	0		
PANEL7	1	0	1	1	8 (DI4-DI11)	-	0	0	0	0	0	0	0	0	0	0	0	0	0	0	0	0		
PANEL8	0	1	1	1	8 (DI4-DI11)	-	0	0	0	0	0	0	0	0	0	0	0	0	0	0	0	0		
PANEL9	1	1	1	1	8 (DI4-DI11)	-	0	0	0	0	0	0	0	0	0	0	0	0	0	0	0	1	0	

Configuration of FUNC1 register

bit	Function	Description
DI4	TEST 0	Fix it to 0.
DI5	Vertical flip display	Flip image vertically (from top to bottom) 0: Normal, 1: Vertical flip
DI6	Horizontal flip display	Flip image horizontally (from side to side) 0: Normal, 1: Horizontally flip
DI7	Backlight control	Set BLON signal that controls external backlight circuitry. 0: Low 1: High
DI8	Standby control	Switch between standby and operation. 0: standby, 1: operation
DI9	TEST 1	Fix it to 0.
DI10	TEST 2	
DI11	TEST 3	

Configuration of FUNC2 register

bit	Function	Description
DI4	HSYNC polarity	Change polarity of HSYNC. 0: Positive polarity, 1: Negative polarity
DI5	VSYNC polarity	Change polarity of VSYNC 0: Positive polarity, 1: Negative polarity
DI6	CLK polarity	Change polarity of CLK. 0: Noninversion 1: Inversion
DI7	TEST 4	Fix it to 1.
DI8	TEST 5	Fix it to 0.
DI9	TEST 6	
DI10	NC	
DI11	NC	-

FUNC3 Register Configuration

bit	Function	Description
DI4	Test 7	Please fix it to "0".
DI5	Test 8	
DI6	GM1[0]	Register for gamma potential correction when input data D [*7:*0] is 192(=C0h).
DI7	GM1[1]	
DI8	GM1[2]	
DI9	GM2[0]	Register for gamma potential correction when input data D[*7:*0] is 148(=94h).
DI10	GM2[1]	
DI11	GM2[2]	

FUNC4 Register Configuration

bit	Function	Description
DI4	Test 9	Please fix to "1".
DI5	Select gamma correction curve	Select gamma correction curves. 0: built-in gamma correction curve 1: user-established gamma correction curve
DI6	GM3[0]	Register for gamma potential correction when input data D [*7:*0] is 108(=6Ch).
DI7	GM3[1]	
DI8	GM3[2]	
DI9	GM4[0]	Register for gamma potential correction when input data D[*7:*0] is 64(=40h).
DI10	GM4[1]	
DI11	GM4[2]	

TEST 0 to TEST 9

Please fix DI4, DI9 through DI11 of the FUNC1 registers to "0".

Please fix DI7 of FUNC2 to "1", DI8 and DI9 of FUNC2 to "0". DI10 and DI11 are no connection.

Please fix DI4 and DI5 of FUNC3 to "0".

Please fix DI4 of FUNC4 to "1".

User Setting Values

Please use "User setting values" to set up PANEL1 through PANEL9, DI4, DI9 through DI11 of FUNC1 and DI7 through DI9 of FUNC2.

Use of unspecified values may cause malfunction.

8.2.4 Detailed Description of Function

(1) BRIGHT CONTROL (BRIGHT)

Bright setting values is controlled by 6 bit (DI6 through DI11) of BRIGHT registers.
The display lightens in proportion to data value while VLCD changes inversely with the data value.

Initial value of BLACK[00h] is 3.73V and WHITE[FFh] is 0.55V when the CONTRAST register is Eh.

The amount of change in VLCD is 0.02V per LSB.

Recommended Operating Range
The register shall be set in 00h to 2Eh range.

(Typ.)

BRIGHT[5:0]	VLCD (BLACK)	VLCD (WHITE)
00h	4.25V	1.07V
01h	4.23V	1.05V
~	~	~
1Ah	3.73V	0.55V
~	~	~
2Dh	3.35V	0.17V
2Eh	3.33V	0.15V

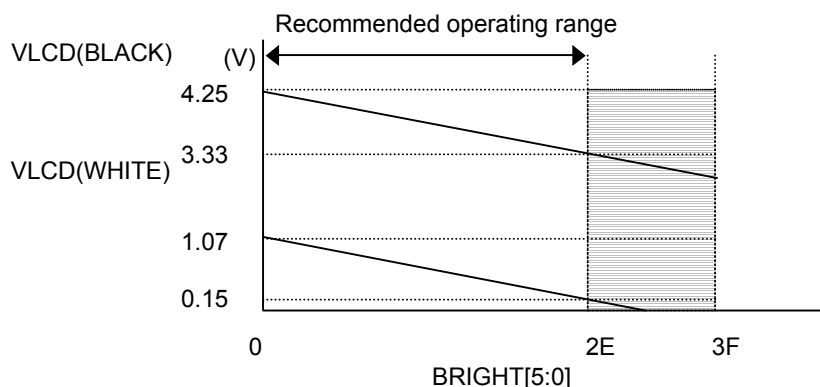
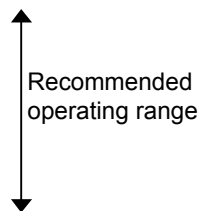

(2) COMMON ELECTRODE CENTER VOLTAGE (VCOMDC)

Common-electrode center voltage is controlled by 6-bit (DI6 through DI11).
The voltage is proportional to data values. Each TFT monitor has to be optimized to its own optimum value separately. This optimization is mandatory. If not implemented, liquid crystal of TFT monitor will be degraded by long operation.

Initial value of VCOMDC is 2.30V.

Amount of change in VCOMDC is 0.02V per LSB.

Recommended Operating Range
Since VCOMDC has its optimum value somewhere between 1.20 and 2.20V, the register should be set in 08h to 3Ah range

(Typ.)

VCOMDC[5:0]	VCOMDC (V)
00h	1.04V
~	~
07h	1.18V
08h	1.20V
~	~
3Ah	2.20V
~	~
3Fh	2.30V

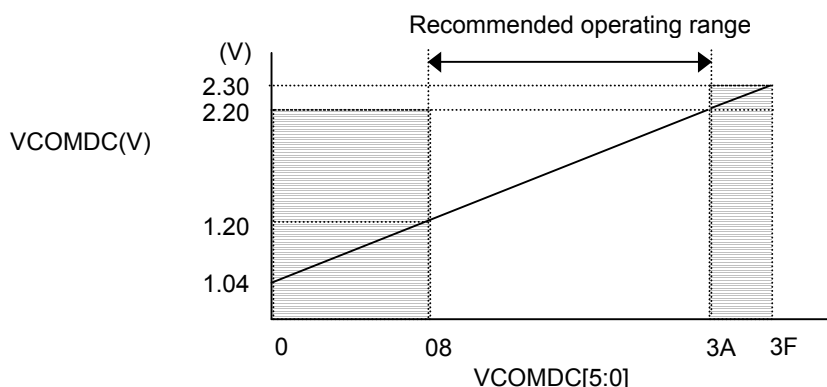
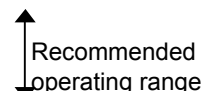

(3) Contrast Control (CONTRAST)

Contrast is controlled in 16 levels by 4-bit (DI4 through DI7) CONTRAST register.

Contrast is proportional to data values. Contrast does not affect aforementioned bright control.

Initial value of Contrast is 3.18V.

Amount of change in contrast is 0.12V per LSB.

(Typ)

CONTRAST[3:0]	VLCD (BLACK) - VLCD (WHITE)
0h	1.50V
~	~
Eh	3.18V
Fh	3.30V

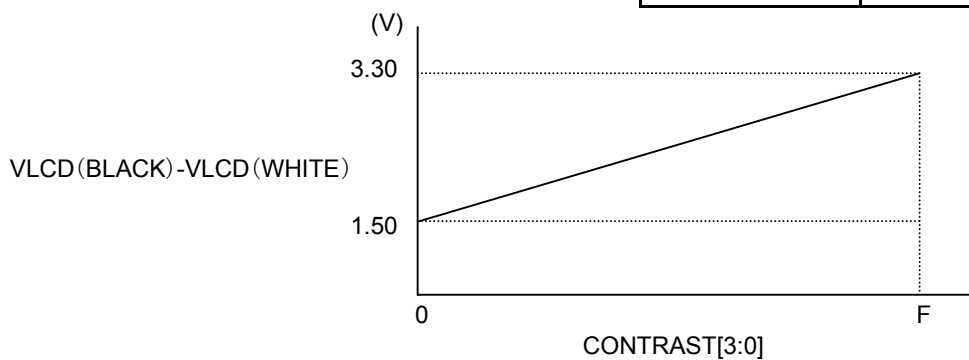

(4) PANEL SETTING 1 (PANEL 1)

Please set this register to these values.

DI9	DI10	DI11
0	0	1

(5) VERTICAL FLYBACK TIME SET (VDISP)

The length of vertical fly back period can be set from 0 to 31H by 5-bit of D14 through D18 of VDISP register. When VSYNC and HSYNC are negative polarity, "Lo" period of VSYNC is detected at the rising edge of HSYNC. The setting value of VDISP is determined by the number of horizontal periods from the first detection of VSYNC=Lo to the first line's display data input. Please set VDISP=1 as shown in "Example 1" even if the display data of the first line is input

When the pulse width of VSYNC extends over two or more H as shown in "Example 3", the setting value is determined by the number of horizontal periods from the first detection of VSYNC=Lo to the first line's display data input. When the initial value is "0", the first line's display data needs to be inputted immediately after VSYNC as shown in "Example 4".

When VDISP=0, please use odd number for the setting of the total number of lines that compose one field. This function can also be used for vertical display range setup (Vertical position setup).

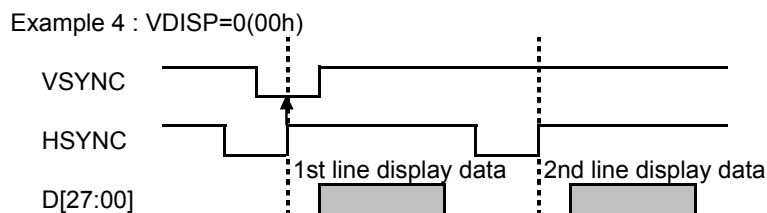
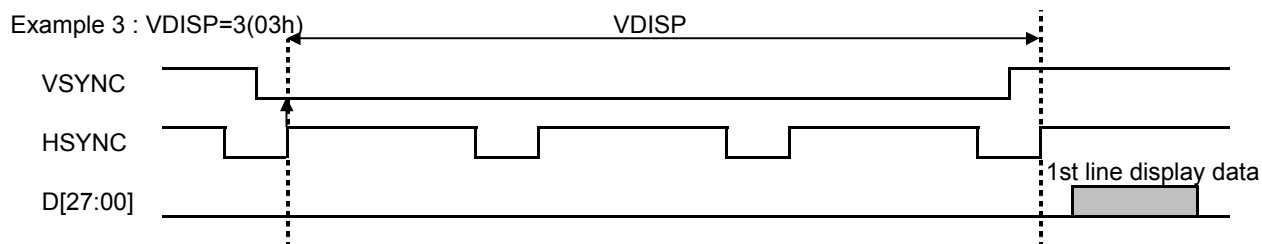
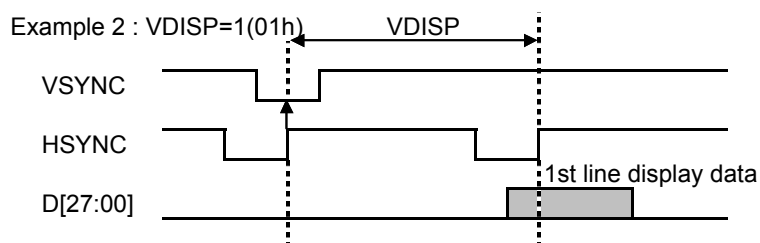
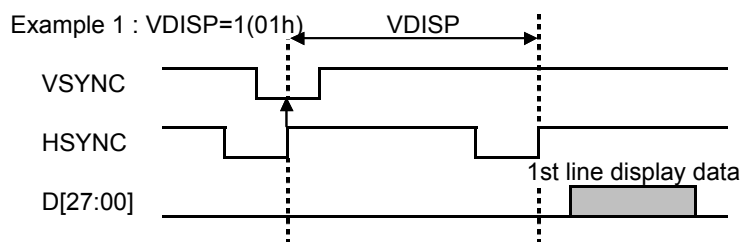

(6) PANEL Setting 2 (PANEL2)

PANEL 2 register 3-bit (DI9 and DI10 and DI11) can select operating conditions from 8 choices. Please set this register to these values.

DI9	DI10	DI11
0	0	0

(7) Horizontal Flyback Period Setting (HDISP)

Horizontal flyback time can be set from 5 to 258CLK by HDISP register with 8-bit of DI14 thru DI11. However, set value of 0 or 1 is prohibited. Actual flyback time is "setting value plus 3CLK". When initial value is 74, a data after a lapse of 74 + 3CLK=77CLK from the rising edge of HSYNC is displayed as shown in the following chart.

This function can also be used for horizontal display range setup (Horizontal position setup).

Example : HDISP=74(4Ah)

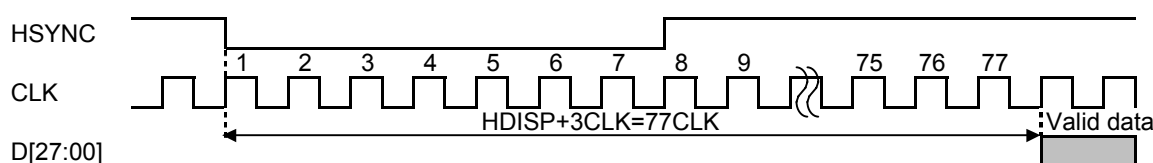

(8) PANEL Setting 3 (PANEL3)

Select operating condition of the signal generated by driver IC in accordance with 8-bit of DI4 to DI11 of PANEL 3 register. Please set this register to these values.

DI4	DI5	DI6	DI7	DI8	DI9	DI10	DI11
0	1	0	0	1	1	0	0

(9) FUNCTION SET 1 (FUNC1)

FUNC1 register sets and controls the following functions by its each bit of DI5,DI6 and di8.

Vertical Flip Display (Up/Down)

DI5=0 for normal display, DI5=1 for vertical flip display

After completing the setup by serial communication, the selected display mode is carried out by VSYNC.
(Normal display is defined when "Product Number" logo on the front case is placed at the bottom.)

Horizontal Flip Display (Right/Left)

DI6=0 for normal display, DI6=1 for horizontal flip display

The selected display mode is executed at VSYNC after setup by serial communication.

(please refer to the section 8.3 for display data transfer)

Backlight Control

DI7 switches the backlight driver IC. BLON terminal outputs set value of DI7.

Since its output level is VDD or VSS, this function can also be used for other controls than the backlight.
After completing the setup by serial communication, the selected display mode is carried out by VSYNC.

Standby Mode

DI8=0 for standby mode, DI8=1 for normal operation

Since default value of DI8 after power on is "0", it automatically goes to standby mode.

Power consumption is significantly reduced in standby mode by disabling the timing generator and the LCD driving circuitry, and disconnecting current lines.

No image is displayed (white raster display) during standby mode unless DI8 is set to 1 for normal operation by serial communication. Serial data can be received by serial communication block even in standby mode. Please refer to the section 8.4 "Standby (Power save) Sequence" for standby mode and power on/off sequence. When normal operation is switched to standby mode, afterimage treatment is carried out before switching to standby mode.

(10) FUNCTION SET 2 (FUNC2)

FUNC2 register sets and controls the following functions by its each bit of DI4 thru DI6.

HSYNC, VSYNC, CLK Polarity Switching

Polarity of HSYNG is switched by DI4. DI4=0 for positive polarity input, DI4=1 for negative polarity input.

Polarity of VSYNC is switched by DI5. DI5=0 for positive polarity input, DI5=1 for negative polarity input.

Polarity of CLK is switched by DI6. DI6=0 for non-inversion, DI6=1 for inversion.

Initial value of DI4, DI5 and DI6 are "1". The following chart shows polarity of each signal at the initial value.

Please set change of VSYNC, HSYNC and display data at the rising edge of CLK.

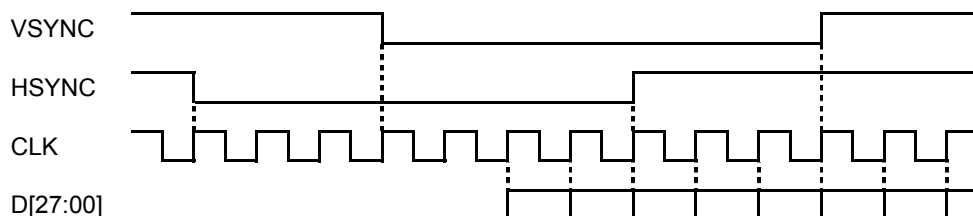

Polarity of each signal can be changed independently by logic of DI4, DI5 and DI6.

Example 1 : DI4=0, DI5=DI6=1 (HSYNC has positive polarity and Hi active)

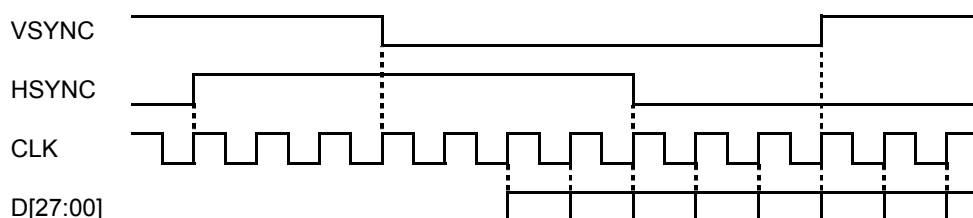

Example 2 : DI4=1, DI5=0, DI6=1 (VSYNC has positive polarity and Hi active)

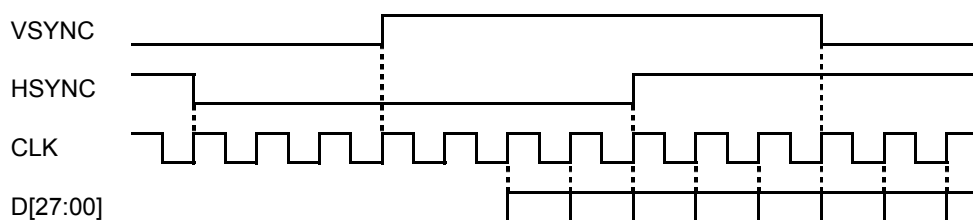

Example 3 : DI4=DI5=1, DI6=0 (CLK is reversed, data is read at the rising edge of CLK.)

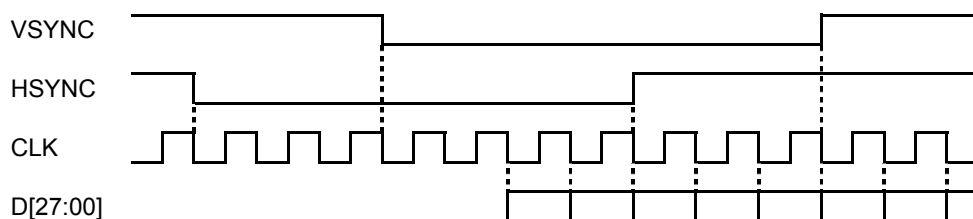

(11) FUNCTION SET 3, 4 (FUNC 3, 4)

Gamma Curve Correction Select

DI5=0 of FUNC 4 Register: Deactivate user configurable gamma correction circuitry.
Use built-in gamma curve.

DI5=1 of FUNC 4 Register: Activate user configurable gamma correction circuitry.
Use user configurable gamma correction curve.

Setting Method of User Configurable Gamma Correction Curve

Gamma curve can be corrected by using GM1[2:0] thru GM4[2:0] registers of FUNC 3 and FUNC 4. GM1 thru GM4 corrects each following gamma potential respectively.

GM1[2:0] → Input data D[*7:*0] = Register for gamma potential correction at 192(=C0h)

GM2[2:0] → Input data D[*7:*0] = Register for gamma potential correction at 148(=94h)

GM3[2:0] → Input data D[*7:*0] = Register for gamma potential correction at 108(=6Ch)

GM4[2:0] → Input data D[*7:*0] = Register for gamma potential correction at 64(=40h)

Below chart shows characteristic curve of gray scale input data - liquid crystal applied voltage. Input value of "0" is assumed to be 0% of applied voltage to liquid crystal, and input value of "255" is assumed to be 100% of applied voltage to liquid crystal. Adjustable range of GM1 thru GM4 registers are described below.

	GM4[2:0]	GM3[2:0]	GM2[2:0]	GM1[2:0]
00h	No correction	No correction	No correction	No correction
01h	54.5%	66.7%	75.8%	84.8%
02h	51.5%	63.6%	72.7%	81.8%
03h	48.5%	60.6%	69.7%	78.8%
04h	45.5%	57.6%	66.7%	75.6%
05h	42.4%	54.5%	63.6%	72.7%
06h	39.4%	51.5%	60.6%	69.7%
07h	36.4%	48.5%	57.6%	66.7%

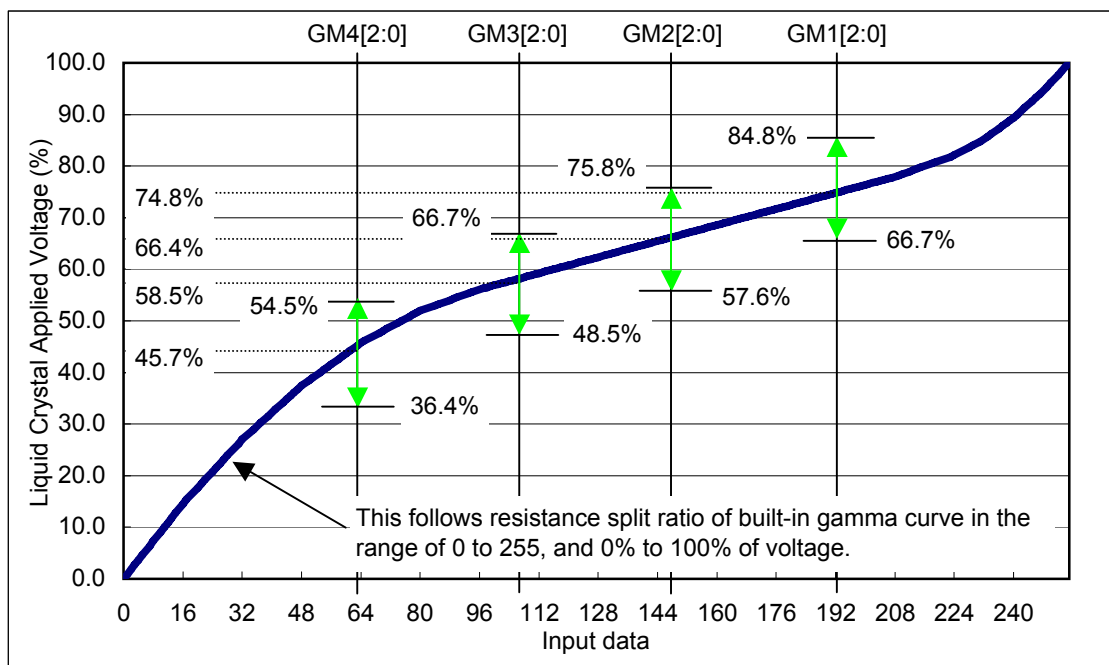

When no correction is made to gamma potential of GM1 to GM4;

The voltages at "0" and "255" are fixed in accordance with the contrast and brightness settings, and voltages at 1 to 254 are determined by resistor split ratio produced by the driver IC built-in gamma curve resistor. (Refer to the chart in previous page)

Liquid crystal applied voltage takes the values of 45.7%, 58.5%, 66.4% and 74.8% when input data is 64, 108, 148 and 192 respectively.

When correction is made to any of GM1 to GM4 by user;

The voltage is corrected in accordance with a correction point and its set value configured by user.

The voltages at 1 to 254 are determined by resistor split ratio between voltage at 0 and 225 and input data.

Example:

Darken gray scale in black side.

→ Change liquid crystal applied voltage at the 64 point to darken side.

→ Set GM4[2:0] to 7h, GM3[2:0] to 6h, GM2[2:0] to 5h and GM1[2:0] to 4h.

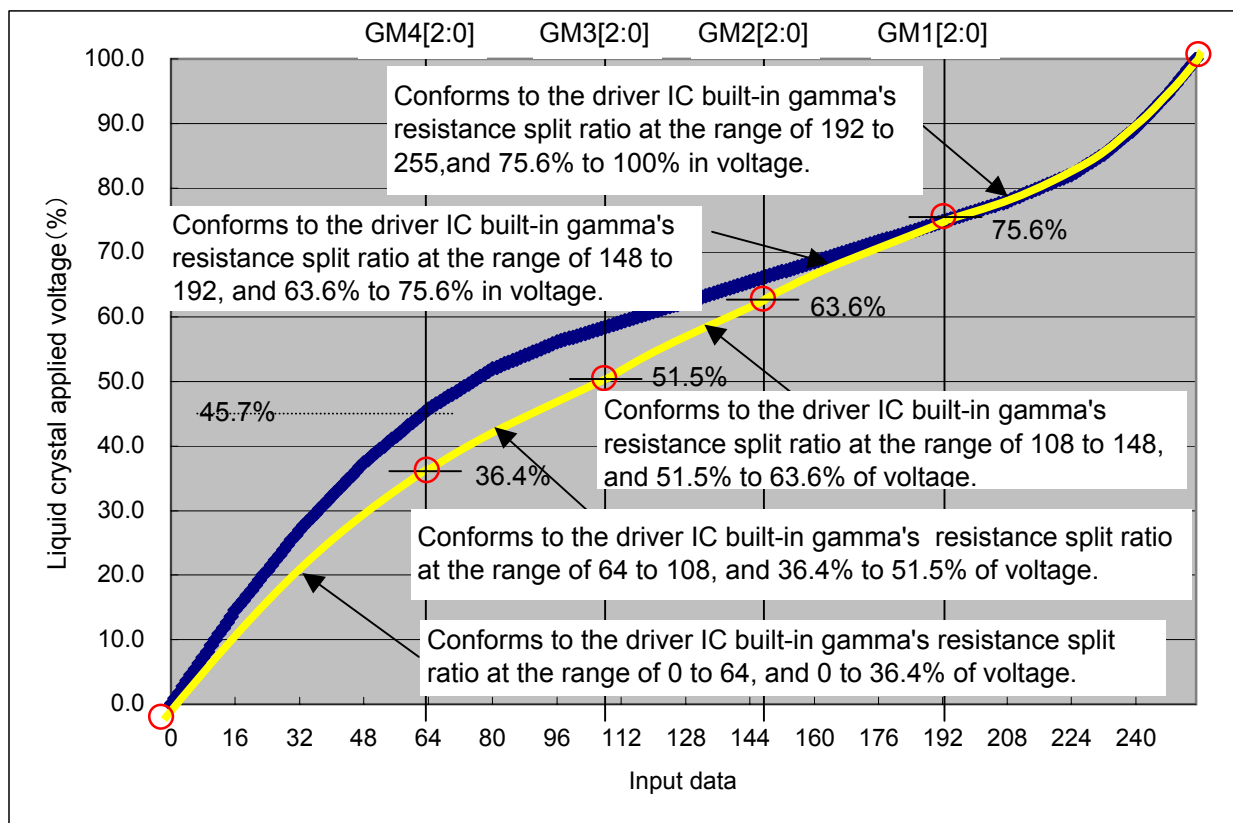

(12) PANEL SELECT 4 (PANEL 4)

Select operating condition of the signal generated by driver IC in accordance with 8-bit of DI4 to DI11 of PANEL 4 register. Please set this register to this value.

DI4	DI5	DI6	DI7	DI8	DI9	DI10	DI11
0	0	0	0	0	0	0	0

(13) PANEL SELECT 5 (PANEL 5)

Select operating condition of the signal generated by driver IC in accordance with 8-bit of DI4 to DI11 of PANEL 5 register. Please set this register to this value.

DI4	DI5	DI6	DI7	DI8	DI9	DI10	DI11
0	1	0	0	0	0	0	0

(14) PANEL SELECT 6 (PANEL 6)

Select operating condition of the signal generated by driver IC in accordance with 8-bit of DI4 to DI11 of PANEL 6 register. Please set this register to this value.

DI4	DI5	DI6	DI7	DI8	DI9	DI10	DI11
0	0	0	0	0	0	0	0

(15) PANEL SELECT 7 (PANEL 7)

Select operating condition of the signal generated by driver IC in accordance with 8-bit of DI4 to DI11 of PANEL 7 register. Please set this register to this value.

DI4	DI5	DI6	DI7	DI8	DI9	DI10	DI11
0	0	0	0	0	0	0	0

(16) PANEL SELECT 8 (PANEL 8)

Select operating condition of the signal generated by driver IC in accordance with 8-bit of DI4 to DI11 of PANEL 8 register. Please set this register to this value.

DI4	DI5	DI6	DI7	DI8	DI9	DI10	DI11
0	0	0	0	0	0	0	0

(17) PANEL SELECT 9 (PANEL 9)

Select operating condition of the signal generated by driver IC in accordance with 8-bit of DI4 to DI11 of PANEL 9 register. Please set this register to this value.

DI4	DI5	DI6	DI7	DI8	DI9	DI10	DI11
0	0	0	0	0	0	1	0

8.3 Display Data Transfer

Input display data to D[27:00] D*0 :LSB, D*7:MSB

Horizontal Timing and Order of Input Data

Display data shall be input in synchronization with CLK.

Polarity of CLK can be selected by DI16 of FUNCTION SET 2 (FUNC2).(at "MODE" = "VSS")

Normal display: Normal display is defined as the orientation that the FPC cable on the TFT monitor is placed on the downside.

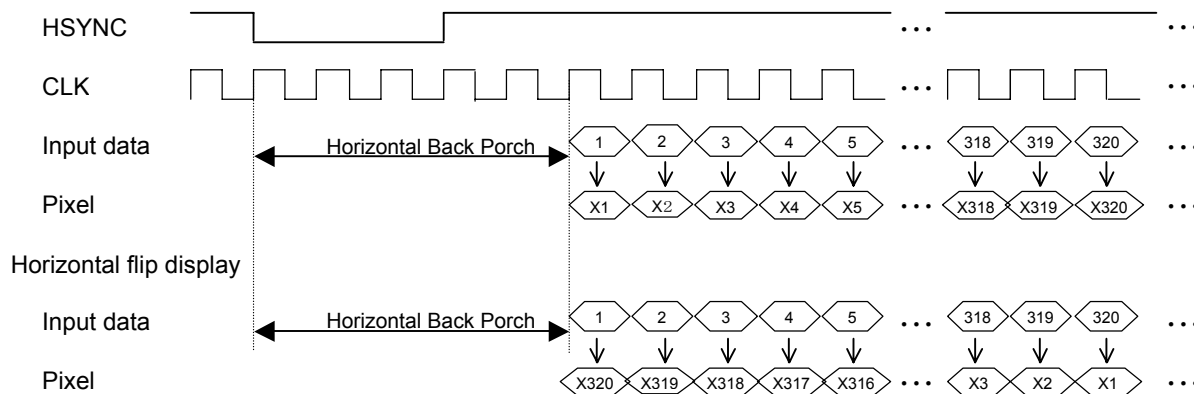

* Above timing chart shows correlation between input data and pixels in visual way and it is not actual timing chart.

Vertical Timing and Order of Input Data

Transfer of display data that consist of 240 lines in 1 field is explained below.

The correlations between input line and display line at normal display and vertical flip display are described below.

Normal display: Normal display is defined as the orientation that the FPC cable on the TFT monitor is placed on the downside.

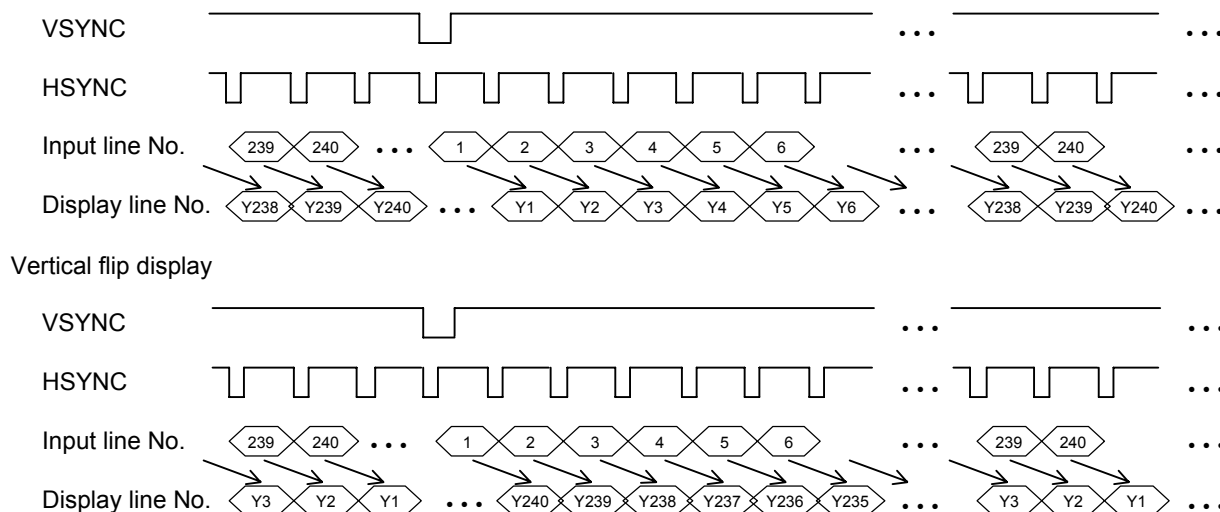

* Above timing chart shows correlation between input data and pixels in visual way and it is not actual timing chart.

8.4 Standby (Power Save) Sequence

When "MODE" = "VSS", serial communication signals of CS, DI and SCK shall be input after VDD stabilizes at $VDD \geq [0.9 \times VDD]V$ for more than 20 msec or more after power on.

All initial values of serial data shall be set during this standby mode.

Other logic input signals of HSYNC, VSYNC, D[27:00] and CLK shall be input simultaneously with VDD or after power on (specified period marked ① in next page). All input signals shall be set to a fixed DC to reduce power consumption during standby mode.

Please follow the recommended power on/off sequence described below.

- ① Right after power on, serial communication registers are initialized.
Therefore, standby control bit takes the value of "0".
By this procedure the LCD goes into standby mode which significantly reduces power consumption of the LCD. No image is displayed (white raster display) on the screen and internal power circuit is deactivated during standby mode.
Sync signal and display data (HSYNC, VSYNC, D[27:00], CLK) start to input before standby mode is released by serial communication.
- ② When the standby control bit is set to "1" by serial communication or the terminal "STBY" turn to "Lo" from "Hi", the standby mode is released by following VSYNC and the power supply circuit of building into begins operating. No image is displayed (white raster display) on the screen for 5 fields from the following VSYNC after the release of standby mode.
- ③ LCD goes into normal display (display under normal operation) at the timing of VSYNC after completion of the procedure described in ②. Backlight shall be lit up 1 or more field after going to normal display.
- ④ Standby mode can be established by setting standby control bit to "0" by serial communication or the terminal "STBY" turn to "Hi" from "Lo".
Display data is changed to FFh at VSYNC that comes right after this serial communication, and afterimage treatment is performed for 2 fields of VSYNC. Displayed image under normal display is immediately changed to white raster display by this treatment.
Continue to input sync signal (HSYNC, VSYNC, CLK) during this period.
- ⑤ LCD goes into standby mode, which is same as ① above, at the timing of VSYNC after completion of the procedure described in ④. Serial communication data is retained during standby mode. Serial communication signal and input signal can be deactivated

② to ④ repeats same procedures as described above.

Below procedure must be followed for power-off.

- ① Implement standby setting.
- ② After standby setting, continue to input sync signals (HSYNC, VSYNC, CLK) during the image treatment period (until VSYNC after 2 fields subsequent to standby setting).
- ③ After ②, power off VDD after 30msec or more
- ④ Stop the sync signals (HSYNC, VSYNC, CLK) subsequent to afterimage treatment period and no later than VDD off.

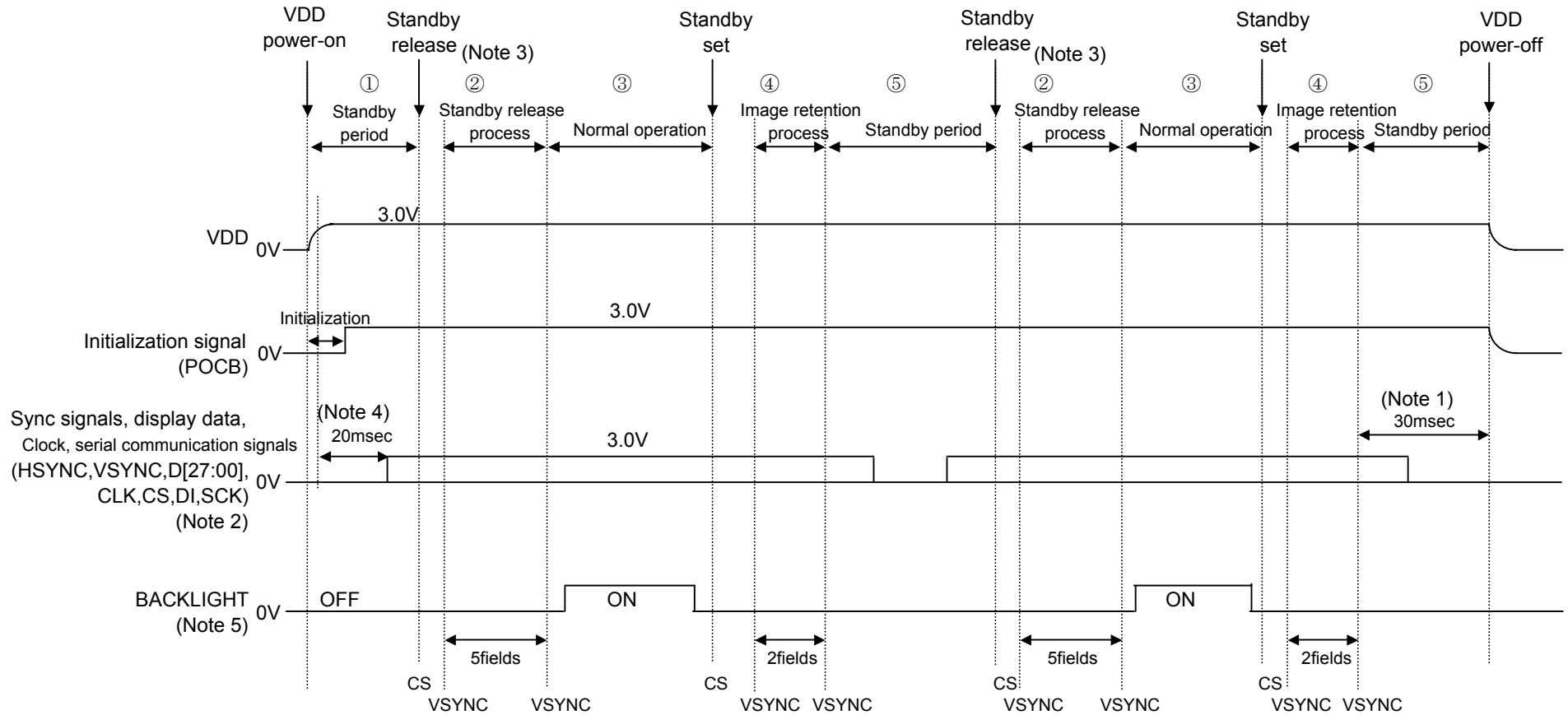

- (Note 1) Power off VDD more than 30 msec after VSYNC that arrives 2 fields from standby set.
- (Note 2) Input CLK during the period of inputting sync signals (HSYNC, VSYNC) and display data D[27:00].
- (Note 3) Due consideration needs to be given to power supply capacity as bigger current (inrush current) flows at standby release.
- (Note 4) Serial communication signals should be input after VDD stabilizes at $VDD \geq [0.9 \times VDD]V$ for more than 20 msec.
And initial values of all serial data should be set during this period before standby release.
- (Note 5) Backlight should be turned on after 1 field from starting display. Backlight should be turned off before standby is set.

Voltage values shown in this chart are typical values, not fixed values.

8.5 Power On Sequence

There is the following limit between a power on period and the serial communication setting.

Power-on-clear circuit diagram

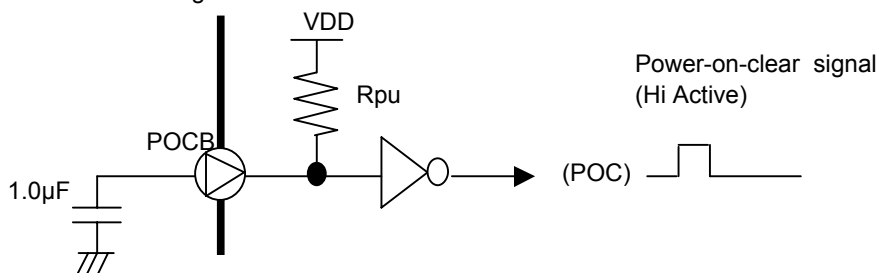

POCB terminal is connected to VDD through the pull-up resistor (Rpu).
 When rising of VDD takes long time, PO CB will have unstable and unpredictable waveform.
 Please determine value of external capacitor by which PO CB takes 1.107 V or less at VDD is 2.7V.

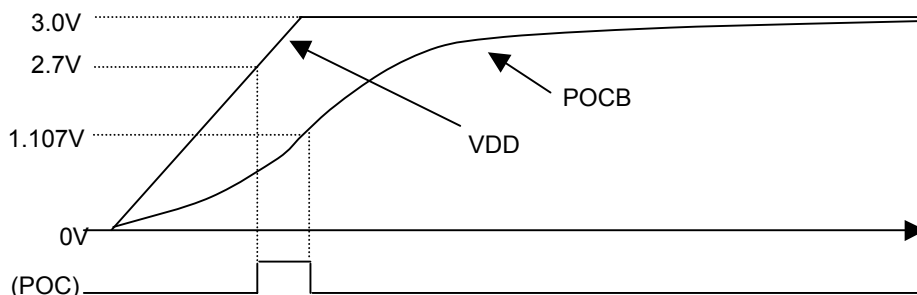

Power On Sequence

Serial Communication Prohibition Period

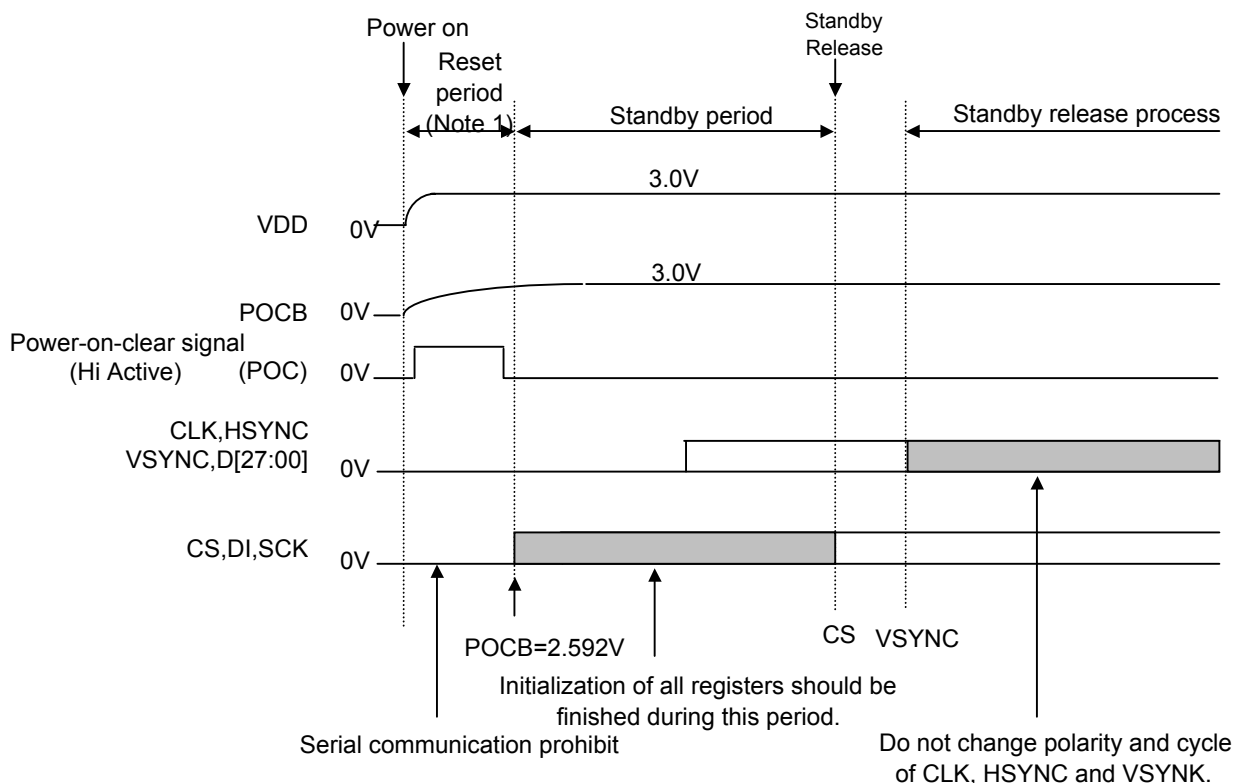

Note 1: All logic input signals are ignored during input period (POC is Hi).

In case of rapid startup after power-on, directly control POCB terminal.

Power-on-clear circuit diagram

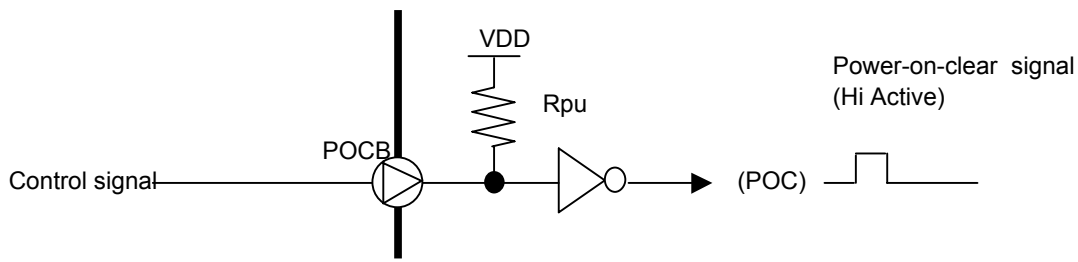

In case of directly controlling POCB terminal, POCB terminal should be set to "Lo" at Power-on. POCB should be changed to "Hi" after VDD is exceeding 2.7V. Serial communication is prohibited while POCB is "Lo".

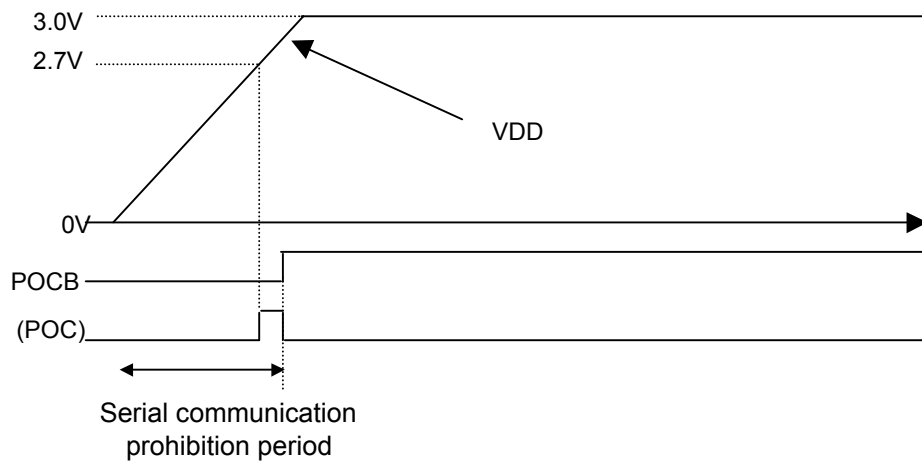

8.6 Other Functions

- Built-in Panel Residual Charge Reduction Circuit

When the power turns off in accordance with the mandatory procedure described in the section "8.4 Standby (Power save) Sequence", afterimage treatment is carried out after standby mode is set. This circuit automatically reduces panel's residual charge and prevents afterimage for a long time even if standby mode setting fails to be made before power-off.

9. CIRCUIT
9.1 "MODE" = "VSS"

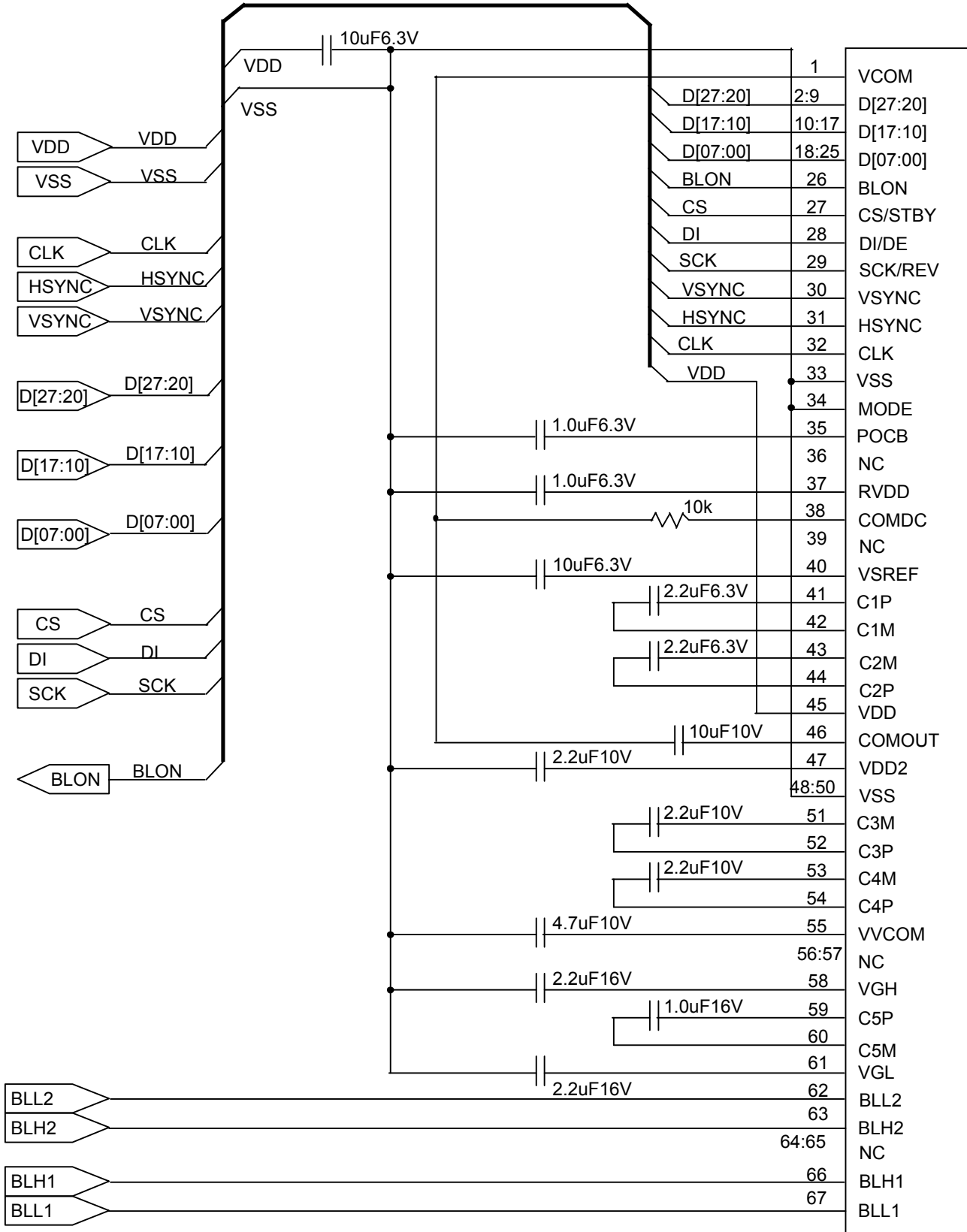

TFT LCD MODULE REFERENCE CIRCUIT

This circuit is solely for reference purpose and optimum circuit and components values may be different. User's due consideration and evaluation must be given to this circuit design and component values prior to their intended use.

9.2 "MODE" = "VDD"

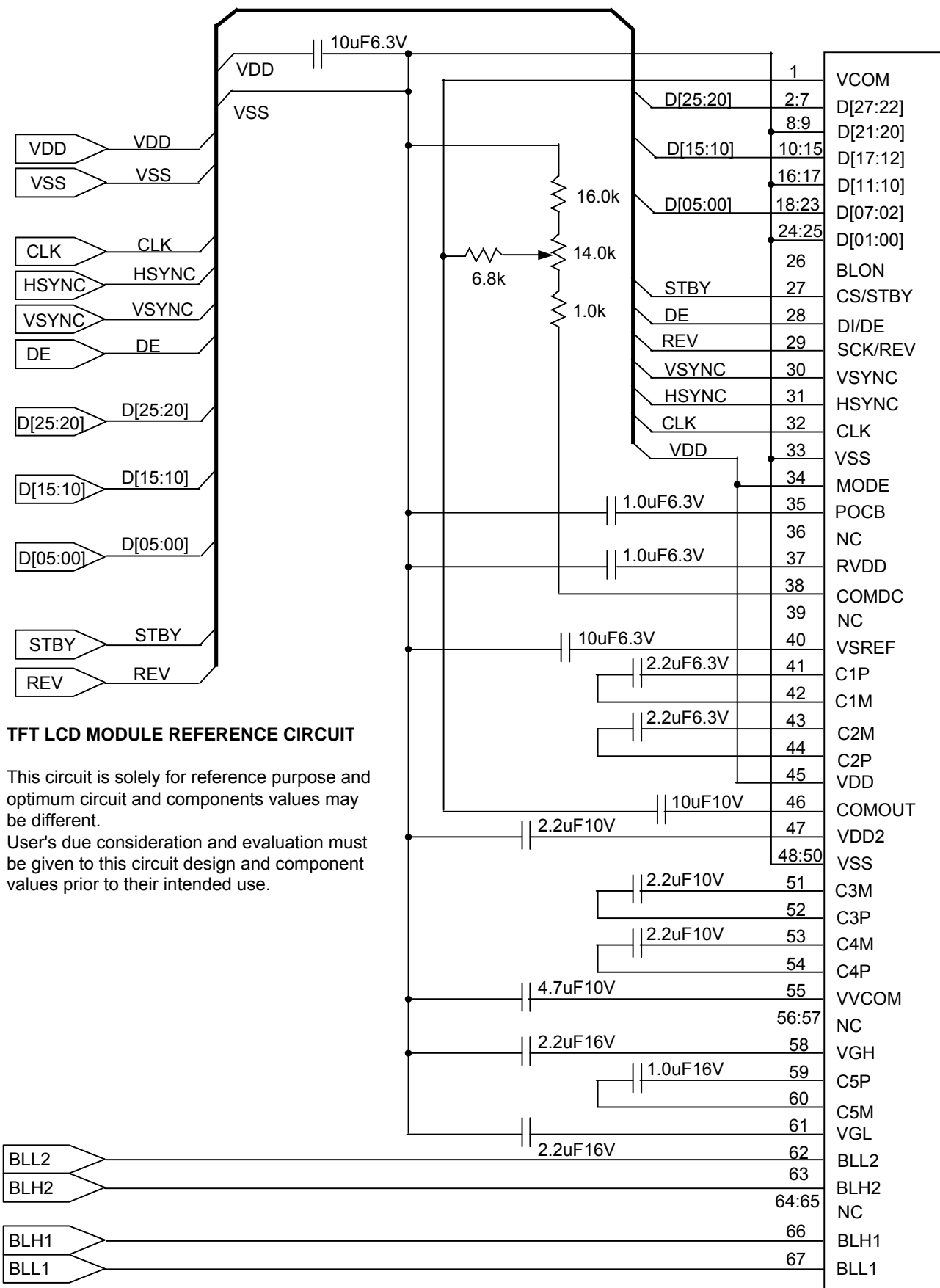

9.3 LED Circuit

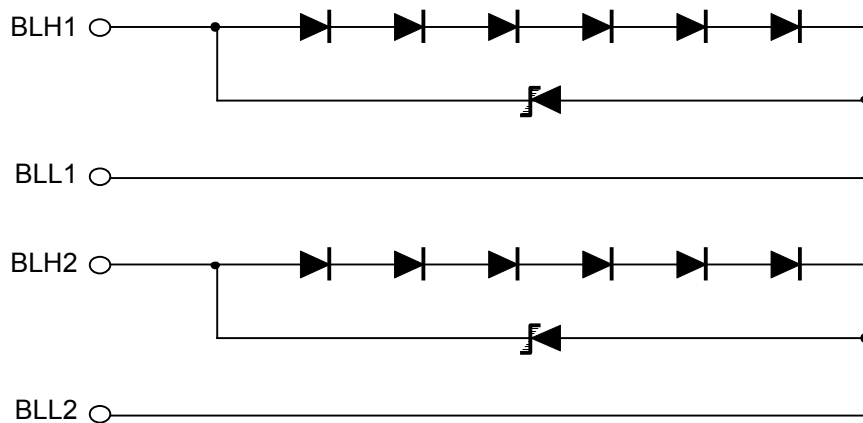

10. CHARACTERISTICS

10.1 Optical Characteristics

< Measurement Condition >

Measuring instruments: CS1000 (KONICA MINOLTA), LCD7000 (OTSUKA ELECTRONICS), EZcontrast160D (ELDIM)

Driving condition: VDD = 3.0V, VSS = 0V
Optimized VCOMDC
VLCD = (Vsigpp ± Vcompp) / 2

Backlight: IL = 20mA

Measured temperature: Ta = 25 °C

Item	Symbol	Condition	MIN	TYP	MAX	Unit	Note No.	Remark
Response time	Rise time	TON VLCD = 0.69V → 3.87V	—	—	40	ms	1	*
	Fall time	TOFF VLCD = 3.87V → 0.69V	—	—	60	ms		
Contrast ratio	CR	VLCD = 0.69V/3.87V	120	200	—		2	
Viewing angle	Left	θL θR φU φD VLCD = 0.69V/3.87V CR ≥ 10	35	—	—	deg	3	*
	Right		35	—	—	deg		
	Up		20	—	—	deg		
	Down		50	—	—	deg		
V-T threshold voltage	V90		0.9	1.2	1.5	V	4	*
	V50		1.4	1.7	2.0	V		
	V10		1.9	2.2	2.5	V		
White V-T Curve			Refer to Fig. 3: White V-T Curve					Reference
White Chromaticity	x	VLCD = 0.69V	Fig. 4: White chromaticity range				5	
	y							
Max. Contrast angle	CRφ		-10	-3	4	deg	6	Downward *
Burn-in			No noticeable burn-in image should be observed after 2 hours				7	At optimized VCOMDC
Brightness at the screen center		VLCD = 0.69V	350	500	—	cd/m ²	8	
Brightness distribution		VLCD = 0.69V	70	—	—	%	9	

* Note number 1 to 9: Refer to the APPENDIX of "Reference Method for Measuring Optical Characteristics".

* Measured in the form of LCD module.

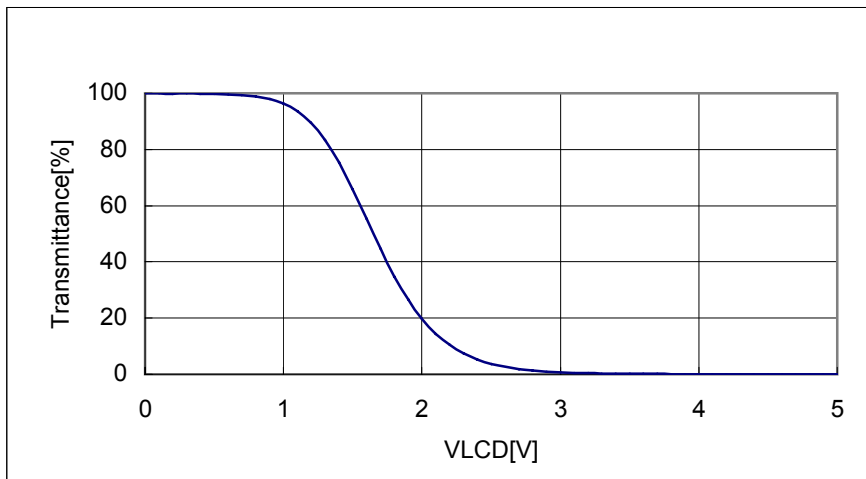
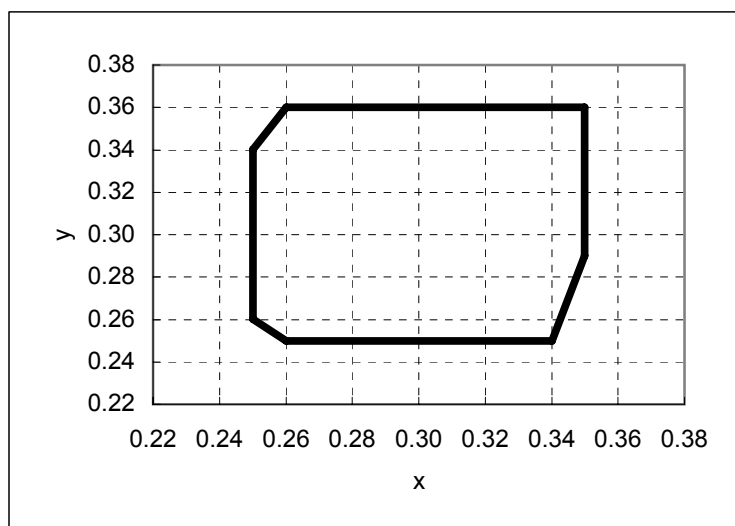

Fig. 3: White V-T Curve



【White Chromaticity Range】

x	y
0.35	0.36
0.26	0.36
0.25	0.34
0.25	0.26
0.26	0.25
0.34	0.25
0.35	0.29

Fig. 4: White Chromaticity Range

10.2 Temperature Characteristics

< Measurement Condition >

Measuring instruments: CS1000 (KONICA MINOLTA), LCD7000 (OTSUKA ELECTRONICS)

Driving condition: VDD = 3.0V, VSS = 0V
Optimized VCOMDC
VLCD = (Vsigpp ± Vcomp) / 2

Backlight: IL = 20mA

Item		Specification		Remark	
		Ta = -10°C	Ta = 70°C		
Contrast ratio	CR	40 or more	40 or more		
Response time	Rise time	TON	200 msec or less	30 msec or less	
	Fall time	TOFF	300 msec or less	50 msec or less	
Display Quality		No noticeable display defect or nonuniformity should be observed.		Use the criteria for judgment specified in the	

11. CRITERIA OF JUDGMENT

11.1 Defective Display and Screen Quality

Test Condition: Observed TFT-LCD monitor from front during operation with the following conditions

Driving Signal	Raster Patter (RGB in monochrome, white, black)
Signal condition	VLCD:0.69V,1.65V,3.87V(3steps)
Observation distance	30 cm
Illuminance	200 to 350 lx
Backlight	IL = 20mA

Defect item	Defect content	Criteria	
Display Quality	Line defect	Black, white or color line, 3 or more neighboring defective dots	
	Dot defect	Uneven brightness on dot-by-dot base due to defective TFT or CF, or dust is counted as dot defect (brighter dot, darker dot) High bright dot: Visible through 2% ND filter at VLCD=3.87V Low bright dot: Visible through 5% ND filter at VLCD=3.87V Dark dot: Appear dark through white display at VLCD=1.65V	
Screen Quality	Dirt	Point-like uneven brightness (white stain, black stain etc)	
	Foreign particle	Point-like	$0.25\text{mm} < \phi$
			$0.20 < \phi \leq 0.25\text{mm}$
			$\phi \leq 0.20\text{mm}$
	Liner	$3.0\text{mm} < \text{length and } 0.08\text{mm} < \text{width}$	
$\text{length} \leq 3.0\text{mm or width} \leq 0.08\text{mm}$			
Others			

$\phi(\text{mm})$: Average diameter = (major axis + minor axis)/2

Permissible number: N

Table 1

Area	High bright dot	Low bright dot	Dark dot	Total	Criteria
A	0	2	2	3	Permissible distance between same color bright dots (includes neighboring dots): 3 mm or more Permissible distance between same color high bright dots (includes neighboring dots): 5 mm or more
B	2	4	4	6	
Total	2	4	4	7	

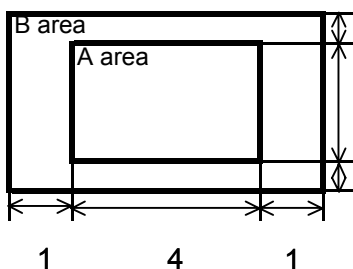

1 Division of A and B areas

B area: Active area

4 Dimensional ratio between A and B areas: 1: 4: 1 (Refer to the left figure)

1

11.2 Screen & Other Appearance

Testing conditions

Illuminance 1200~2000 lx
 Observation distance 30cm

Item		Criteria	Remark
Polarizer	Flaw	Ignore invisible defect when the backlight is on.	Applicable area: Active area only (Refer to the section 3.2 "Outward form")
	Stain		
	Bubble		
	Dust Dent		
S-case		No functional defect occurs	
FPC cable		No functional defect occurs	

12. RELIABILITY TEST

Test item		Test condition		number of failures /number of examinations
Durability test	High temperature storage	Ta=80° C	240H	0/3
	Low temperature storage	Ta=-30° C	240H	0/3
	High temperature & high humidity test	Ta=60° C, RH=90% non condensing	240H	0/3
	High temperature operation	Tp=70° C	240H	0/3
	Low temperature operation	Tp=-20° C	240H	0/3
	High temp & humid operation	Tp=40° C, RH=90% non condensing	240H	0/3
	Thermal shock storage	-30←→80° C(30min/30min)	100 cycles	0/3
Mechanical environmental test	Electrostatic discharge test (Non operation)	Confirms to EIAJ ED-4701/300 C=200pF, R=0Ω, V=±200V Each 3 times of discharge on and power supply and other terminals.		0/3
	Surface discharge test (Non operation)	C=250pF, R=100Ω, V=±12kV Each 5 times of discharge in both polarities on the center of screen with the case grounded.		0/3
	Vibration test	Total amplitude 1.5mm, f=10 ~55Hz, X,Y,Z directions for each 2 hours		0/3
	FPC tensile test	Pull the FPC with the force of 3N for 10 sec. in the direction - 90-degree to its original direction.		0/3
	FPC bend test	Pull the FPC with the force of 3N for 10 sec. in the direction -180-degree to its original direction. Reciprocate it 3 times.		0/3
	Impact test	Use ORTUS TECHNOLOGY original jig (see next page)and make an impact with peak acceleration of 1000m/s ² for 6 msec with half sine-curve at 3 times to each X, Y, Z directions in conformance with JIS 60068-2-27-1995.		0/3
Packing test	Packing vibration-proof test	Acceleration of 19.6m/s ² with frequency of 10→55→10Hz, X,Y, Zdirection for each 30 minutes		0/1 Packing
	Packing drop test	Drop from 75cm high. 1 time to each 6 surfaces, 3 edges, 1 corner		0/1 Packing

Note: Ta=ambient temperature Tp=Panel temperature

※ The profile of high temperature/humidity storage and High Temperature/humidity operation
(Pure water of over 10MΩ·cm shall be used.)

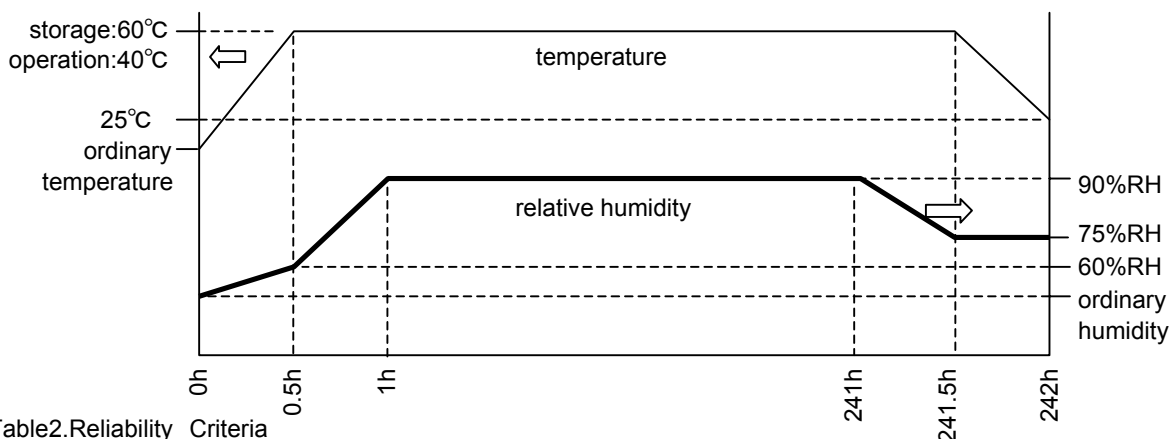
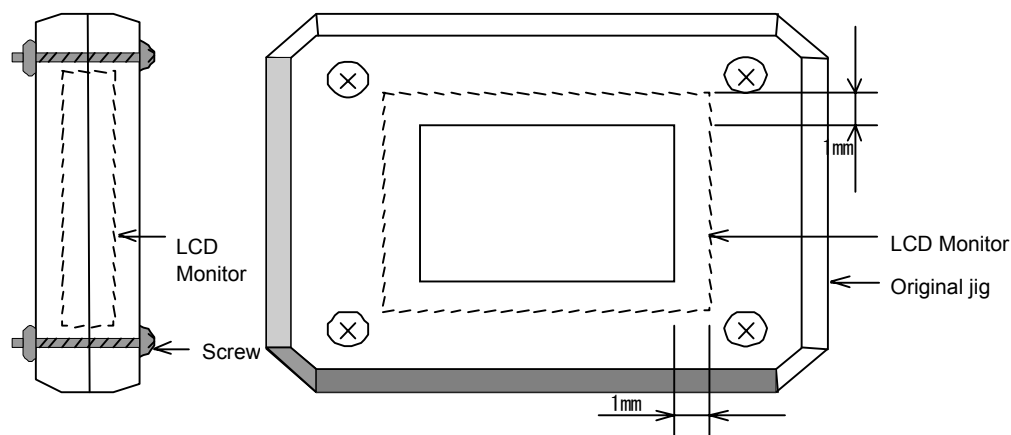

Table2.Reliability Criteria

Measure the parameters after leaving the monitor at the ordinary temperature
for 2 hours or more after the test completion.

item	Standard	Remarks
Display quality	No visible abnormality shall be seen.	As criteria of 11"CRITERIA OF JUDGMENT".
Contrast ratio	40 or more	

ORTUS TECHNOLOGY Original Jig



Tension Test Method for FPC cable

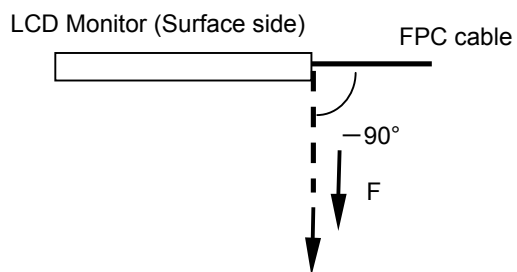

Bend Test Method for FPC cable

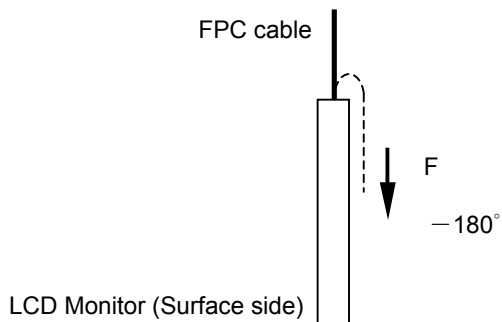

13. PACKING SPECIFICATIONS

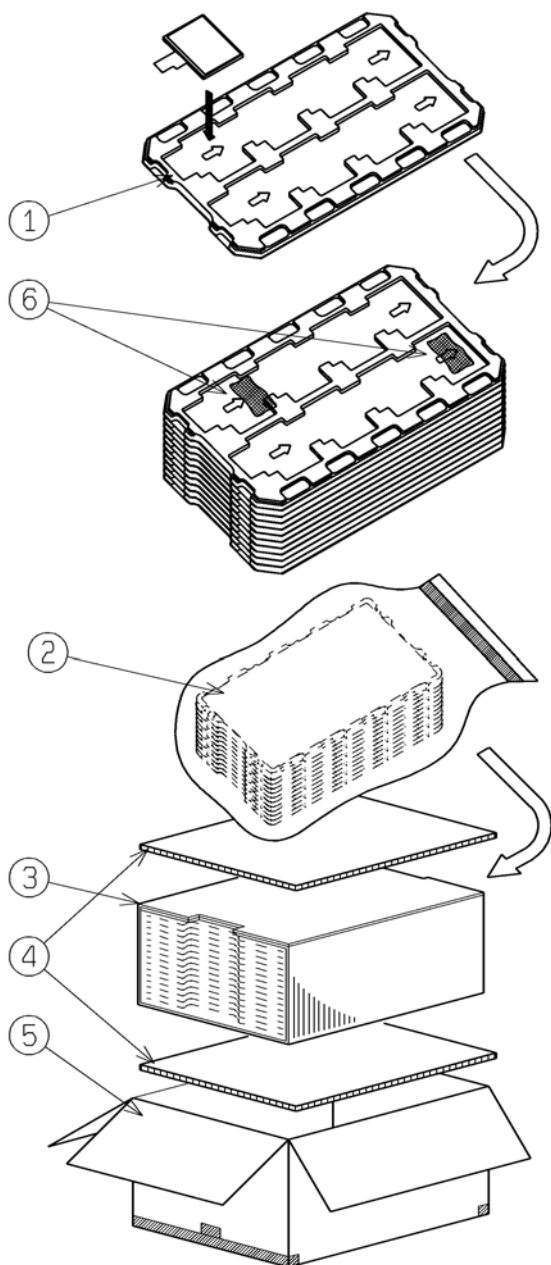

- Step 1. Each product is to be placed in one of the cut-outs of the tray with the display surface facing downward.
(8 products per tray)
- Step 2. Each tray needs to be same orientation respect to the tray below or above it and the trays be in a stack of 10.
One empty tray is to be put on the top of stack of 10 trays.
- Step 3. 2 packs of moisture absorbers are to be placed on the top tray as shown in the drawing.
Put piled trays into a sealing bag.
Vacuum and seal the sealing bag with the vacuum sealing machine.
- Step 4. The stack of trays in the plastic back is to be inserted into a inner carton.
- Step 5. A corrugated board is to be placed on the top and on the bottom of the inner carton.
The two corrugated boards and the inner carton is to be inserted into an outer carton.
- Step 6. The outer carton needs to sealed with packing tape as shown in the drawing.
The model number, quantity of products, and shipping date are to be printed on the outer carton.
If necessary, shipping labels or impression markings are to be put on the outer carton.
- Step 7. The outer carton is to be inserted into a extra outer carton with same direction.
The extra outer carton needs to sealed with packing tape as shown in the drawing.
- Step 8. The model number, quantity of products, and shipping date are to be printed on the extra outer carton.
If necessary, shipping labels or impression markings are to be put on the extra outer carton.

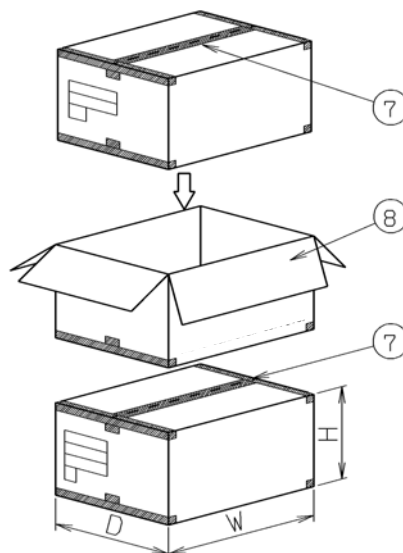

Remark: The return of packing materials is not required.

	Packing item name	Specs., Material
①	Tray	PP Conductive
②	Sealing bag	
③	Inner carton	Corrugated cardboard
④	Inner board	Corrugated cardboard
⑤	Outer carton	Corrugated cardboard
⑥	Drier	Moisture absorber
⑦	Packing tape	
⑧	Extra outer carton	Corrugated cardboard

Dimension of extra outer carton	
D : Approx.	(338mm)
W : Approx.	(549mm)
H : Approx.	(198mm)
Quantity of products packed in one carton:	80
Gross weight : Approx.	8.4kg

14. HANDLING INSTRUCTION

14.1 Cautions for Handling LCD panels

**Caution**

- (1) Do not make an impact on the LCD panel glass because it may break and you may get injured from it.
- (2) If the glass breaks, do not touch it with bare hands.
(Fragment of broken glass may stick you or you cut yourself on it.)
- (3) If you get injured, receive adequate first aid and consult a medical doctor.
- (4) Do not let liquid crystal get into your mouth.
(If the LCD panel glass breaks, try not let liquid crystal get into your mouth even toxic property of liquid crystal has not been confirmed.)
- (5) If liquid crystal adheres, rinse it out thoroughly.
(If liquid crystal adheres to your cloth or skin, wipe it off with rubbing alcohol or wash it thoroughly with soap. If liquid crystal gets into eyes, rinse it with clean water for at least 15 minutes and consult an eye doctor.)
- (6) If you scrap this products, follow a disposal standard of industrial waste that is legally valid in the community, country or territory where you reside.
- (7) Do not connect or disconnect this product while its application products is powered on.
- (8) Do not attempt to disassemble or modify this product as it is precision component.
- (9) A part of soldering part has been exposed, and avoid contact (short-circuit) with a metallic part of the case etc. about FPC of this model, please.
Please insulate it with the insulating tape etc. if necessary.
The defective operation is caused, and there is a possibility to generation of heat and the ignition.
- (10) Since excess current protection circuit is not built in this TFT module, there is the possibility that LCD module or peripheral circuit become feverish and burned in case abnormal operation is generated.
We recommend you to add excess current protection circuit to power supply.

**Caution**

This mark is used to indicate a precaution or an instruction which, if not correctly observed, may result in bodily injury, or material damages alone.

14.2 Precautions for Handling

- 1) Wear finger tips at incoming inspection and for handling the TFT monitors to keep display quality and keep the working area clean.
Do not touch the surface of the polarizer as it is easily scratched.
- 2) Wear grounded wrist-straps and use electrostatic neutralization blowers to prevent static charge and discharge when handling the TFT monitors as the LED in this TFT monitors is damageable to electrostatic discharge,
Properly set up equipment, jigs and machines, and keep working area clean and tidy for handling the TFT monitors.
- 3) Avoid strong mechanical shock including knocking, hitting or dropping to the TFT monitors for protecting their glass parts. Do not use the TFT monitors that have been experienced dropping or strong mechanical shock.
- 4) Do not use or storage the TFT monitors at high temperature and high humidity environment. Particularly, never use or storage the TFT monitors at a location where condensation builds up.
- 5) Avoid using and storing TFT monitors at a location where they are exposed to direct sunlight or ultraviolet rays to prevent the LCD panels from deterioration by ultraviolet rays.
- 6) Do not stain or damage the contacts of the FPC cable .
FPC cable needs to be inserted until it can reach to the end of connector slot.
During insertion, make sure to keep the cable in a horizontal position to avoid an oblique insertion.
Otherwise, it may cause poor contact or deteriorate reliability of the FPC cable.
- 7) Do not bend or pull the FPC cable or carry the TFT monitor by holding the FPC cable.
- 8) Peel off the protective film on the TFT monitors during mounting process.
Refer to the section 14.5 on how to peel off the protective film.
We are not responsible for electrostatic discharge failures or other defects occur when peeling off the protective film.

14.3 Precautions for Operation

- 1) Since this TFT monitors are not equipped with light shielding for the driver IC, do not expose the driver IC to strong lights during operation as it may cause functional failures.
- 2) When driving the monitor, refer to "8.4 Standby (Power Save) Sequence".
When turning off the power, turn off the input signal before or at the same timing of switching off the power.
- 3) Optimize VCOMDC within recommended operating conditions.
* When VCOMDC is not an optimal value, flicker and image sticking will be occurred.
- 4) Do not plug in or out the FPC cable while power supply is switch on.
Plug the FPC cable in and out while power supply is switched off.
- 5) Do not operate the TFT monitors in the strong magnetic field. It may break the TFT monitors.
- 6) Do not display a fixed image on the screen for a long time.
Use a screen-saver or other measures to avoid a fixed image displayed on the screen for a long time. Otherwise, it may cause burn-in image on the screen due the characteristics of liquid crystal.

14.4 Storage Condition for Shipping Cartons

Storage environment

- Temperature 0 to 40° C
 - Humidity 60%RH or less
No-condensing occurs under low temperature with high humidity condition.
 - Atmosphere No poisonous gas that can erode electronic components and/or wiring materials should be detected.
 - Time period 3 months
 - Unpacking To prevent damages caused by static electricity, anti-static precautionary measures (e.g. earthing, anti-static mat) should be implemented.
- Maximum piling up 7 cartons

14.5 Precautions for Peeling off the Protective film

The followings work environment and work method are recommended to prevent the TFT monitors from static damage or adhesion of dust when peeling off the protective films.

A) Work Environment

- a) Humidity: 50 to 70 %RH, Temperature 15° C to 27° C
- b) Operators should wear conductive shoes, conductive clothes, conductive finger tips and grounded wrist-straps. Anti-static treatment should be implemented to work area's floor.
- c) Use a room shielded against outside dust with sticky floor mat laid at the entrance to eliminate dirt.

B) Work Method

The following procedures should taken to prevent the driver ICs from charging and discharging.

- a) Use an electrostatic neutralization blower to blow air on the TFT monitors to its lower left when the FPC cable is facing to the downside.
Optimize direction of the blowing air and the distance between the TFT monitors and the electrostatic neutralization blower.
- b) Put an adhesive tape (Scotch tape, etc) at the lower left corner area of the protective film to prevent scratch on the touch panel.
- c) Peel off the adhesive tape slowly (spending more than 2 secs to complete) by pulling it to opposite direction.

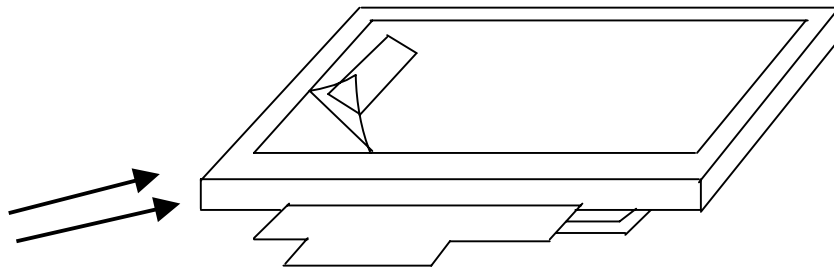

Direction of blowing air
(Optimize air direction and the distance)

APPENDIX

Reference Method for Measuring Optical Characteristics and Performance

1. Measurement Condition

- Measuring instruments: CS1000(KONICA MINOLTA) , LCD7000(OTSUKA ELECTRONICS) , EZcontrast160D(ELDIM)
- Driving condition: Refer to the section 10.1 "Optical Characteristics"
- Measured temperature: 25° C unless specified
- Measurement system: See the chart below. The luminance meter is placed on the normal line of measurement system.
- Measurement point: At the center of the screen unless otherwise specified

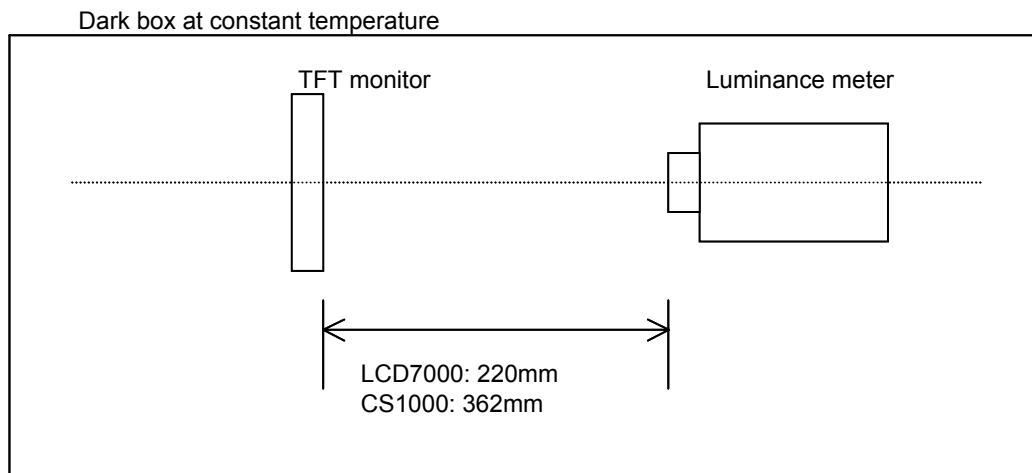

Measurement is made after 30 minutes of lighting of the backlight.

- Measurement point: At the center point of the screen
- Brightness distribution: 9 points shown in the following drawing.

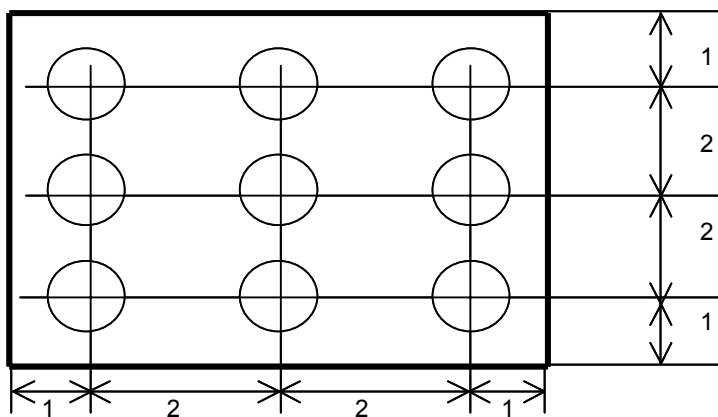

Backlight IL = 20mA

Unit: fraction

2. Test Method

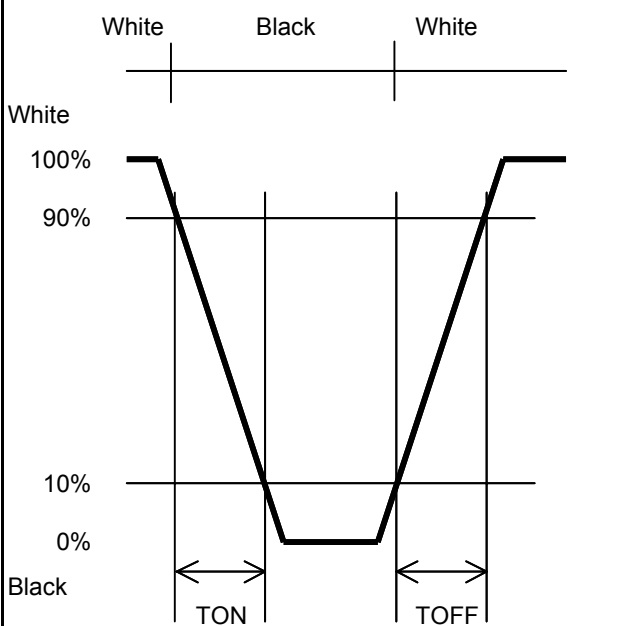
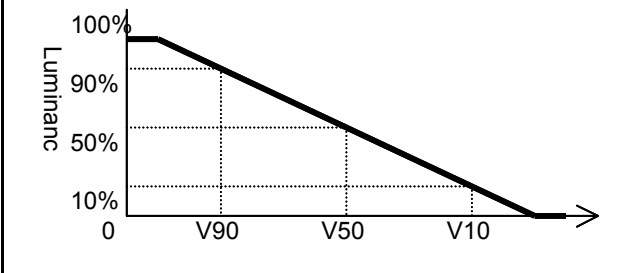
Notice	Item	Test method	Measuring instrument	Remark
1	Response time	Measure output signal waveform by the luminance meter when raster of window pattern is changed from white to black and from black to white. 	LCD7000	Black display VLCD=3.87V White display VLCD=0.69V TON Rise time TOFF Fall time
2	Contrast ratio	Measure maximum luminance Y1(VLCD=0.69V) and minimum luminance Y2(VLCD=3.87V) at the center of the screen by displaying raster or window pattern. Then calculate the ratio between these two values. Contrast ratio = Y1/Y2 Diameter of measuring point: 8mmφ	CS1000	
3	Viewing angle Horizontalθ Verticalφ	Move the luminance meter from right to left and up and down and determine the angles where contrast ratio is 10.	EZcontrast160D	
4	V-T threshold value	Change VLCD by 0.1V step and plot the points where the luminance is 90% as V90, 50% as V50 and 10% as V10 of maximum luminance. 	LCD7000	
5	White chromotically	Measure chromaticity coordinates x and y of CIE1931 colorimetric system at VLCD = 0.69V Color matching faction: 2°view	CS1000	

Notice	Item	Test method	Measuring instrument	Remark
6	Maximum contrast angle	Move the luminance meter vertically to the display from its normal line and measure the angles where contrast ratio reaches its highest value.	EZcontrast160D	
7	Burn-in	Visually check burn-in image on the screen after 2 hours of "window display" (VLCD=0.69V/3.87V).		At optimized VCOMDC
8	Center brightness	Measure the brightness at the center of the screen.	CS1000	
9	Brightness distribution	(Brightness distribution) = $100 \times B/A \%$ A : max. brightness of the 9 points B : min. brightness of the 9 points	CS1000	