

Specifications for TFT-LCD Monitor

Version 2.0

MODEL COM57T5M61ZRC

Customer's Approval
Signature:
Name:
Section:
Title:
Date:

ORTUSTECH

ORTUS TECHNOLOGY CO., LTD.
Sales Dept.

Approved by

T. Tamura

Checked by

ORTUS TECHNOLOGY CO., LTD.
Product Quality Assurance

Approved by

N. Konya

Checked by

E. Takabe

Prepared by

M. Tojo

Version History

Ver.	Date	Page	Description
1.0	Jul. 17, 2012	-	- First issue
2.0	Sep. 14, 2012 △ A ×2	P.23 P.24	Correct 12.2 Screen and Other Appearance Criteria of Touch Panel Correct 13. Reliability Test JIS № (Impact test)

Contents

1. Application	4
2. Outline Specifications		
2.1 Features of the Product	5
2.2 Display Method	5
3. Dimensions and Shape		
3.1 Dimensions	5
3.2 Outward Form	6
3.3 Serial Label (S-Label)	8
4. Pin Assignment	9
5. Block Diagram	11
6. Absolute Maximum Rating	12
7. Recommended Operating Conditions	12
8. Characteristics		
8.1 DC Characteristics	12
8.2 AC Characteristics	14
8.3 Input Timing Characteristics	15
8.4 Driving Timing Chart	16
8.5 Example of Driving Timing Chart	17
9. "DISP" on/off Sequence	18
10. Touch Panel Circuit	19
11. Characteristics		
11.1 Optical Characteristics	20
11.2 Temperature Characteristics	21
12. Criteria of Judgment		
12.1 Defective Display and Screen Quality	22
12.2 Screen and Other Appearance	23
13. Reliability Test	24
14. Packing Specifications	26
15. Handling Instruction		
15.1 Cautions for Handling LCD panels	27
15.2 Precautions for Handling	28
15.3 Precautions for Operation	28
15.4 Storage Condition for Shipping Cartons	29
15.5 Precautions for Peeling off the Protective film	29
APPENDIX	30

1. Application

This Specification is applicable to 14.4 cm (5.7 inch) TFT-LCD monitor for non-military use.

- ⊙ ORTUS TECHNOLOGY makes no warranty or assume no liability that use of this Product and/or any information including drawings in this Specification by Purchaser is not infringing any patent or other intellectual property rights owned by third parties, and ORTUS TECHNOLOGY shall not grant to Purchaser any right to use any patent or other intellectual property rights owned by third parties. Since this Specification contains ORTUS TECHNOLOGY's confidential information and copy right, Purchaser shall use them with high degree of care to prevent any unauthorized use, disclosure, duplication, publication or dissemination of ORTUS TECHNOLOGY'S confidential information and copy right.
- ⊙ If Purchaser intends to use this Products for an application which requires higher level of reliability and/or safety in functionality and/or accuracy such as transport equipment (aircraft, train, automobile, etc.), disaster-prevention/security equipment or various safety equipment, Purchaser shall consult ORTUS TECHNOLOGY on such use in advance.
- ⊙ This Product shall not be used for application which requires extremely higher level of reliability and/or safety such as aerospace equipment, telecommunication equipment for trunk lines, control equipment for nuclear facilities or life-support medical equipment.
- ⊙ ORTUS TECHNOLOGY assumes no liability for any damage resulting from misuse, abuse, and/or miss-operation of the Product deviating from the operating conditions and precautions described in the Specification.
- ⊙ If any issue arises as to information provided in this Specification or any other information, ORTUS TECHNOLOGY and Purchaser shall discuss them in good faith and seek solution.
- ⊙ ORTUS TECHNOLOGY assumes no liability for defects such as electrostatic discharge failure occurred during peeling off the protective film or Purchaser's assembly process.
- ⊙ This Product is compatible for RoHS directive.

Object substance	Maximum content [ppm]
Cadmium and its compound	100
Hexavalent Chromium Compound	1000
Lead & Lead compound	1000
Mercury & Mercury compound	1000
Polybrominated biphenyl series (PBB series)	1000
Polybrominated biphenyl ether series (PBDE series)	1000

2. Outline Specifications

2.1 Features of the Product

- 5.7 inch diagonal display, 1,920 [H] x 480 [V] dots.
- 6-bit 262,144 color display capability.
- 3.3V[TFT-LCD module] is required.
- Built in Timing generator (TG).
- Long life & high brightness LED back-light,built in LED driver and Touch panel operation monitor.
- All-in-one type monitor with lead-free mounting(Response to RoHS Phase 3A).

2.2 Display Method

Items	Specifications	Remarks
Display type	TN type 262,144 colors. Transmissive type, Normally white	
Driving method	a-Si TFT Active matrix Line-scanning, Non-interlace	
Dot arrangement	RGB stripe arrangement	Refer to "Dot arrangement"
Signal input method	6-bit RGB, parallel input.	
Backlight type	Long life & High bright white LED.	Surface finishing:Anti-Glare

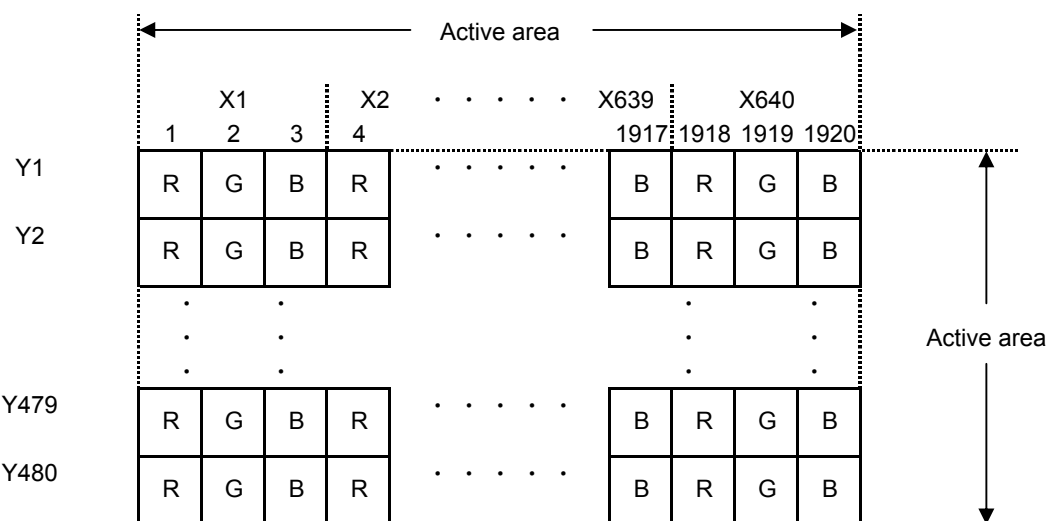

Dot arrangement

(When "S LABEL" on the front case is placed at the bottom)

3. Dimensions and Shape

3.1 Dimensions

Items	Specifications	Unit	Remarks
Outline dimensions	130.32[H] × 101.20[V] × 6.93[D]	mm	
Active area	115.20[H] × 86.40[V]	mm	14.4cm diagonal
Number of dots	1,920[H] × 480[V]	dot	
Dot pitch	60.00[H] × 180.00[V]	μm	
Hardness of Touch Panel surface	3	H	Load:4.9N,Angle:45° Reference judgment standard:JIS-K5600
Weight	161	g	

3.2 Outward Form

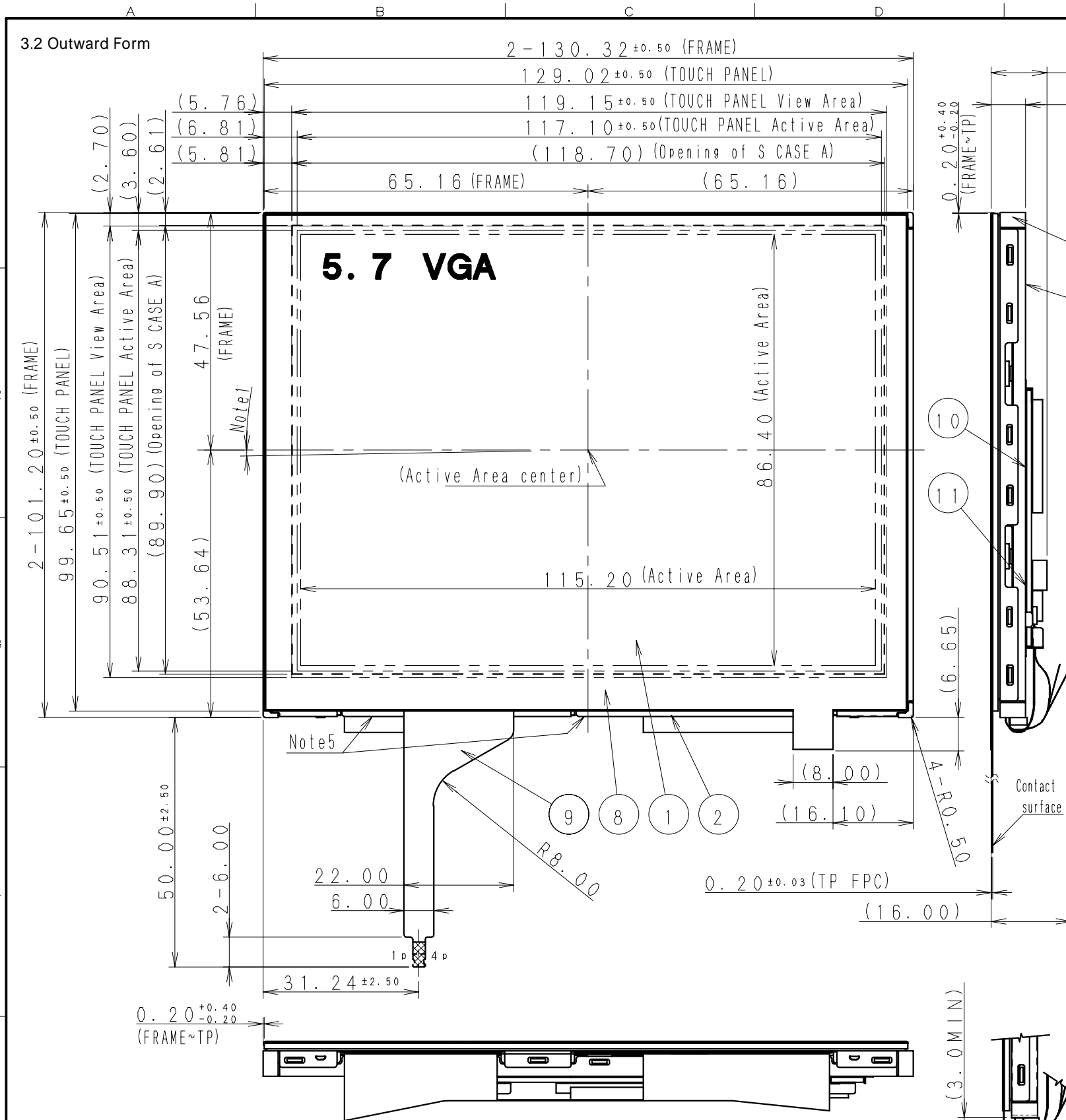

(6/33)
12TLM021
Issue: Sep. 14, 2012

EC No.	REV.No.	REVISE	DATE (Y:M:D)	APPROVED	CHECKED	PREPARED
--------	---------	--------	--------------	----------	---------	----------

* The hatching area is recommended holding area.
Recommended weight: Parallel 2kgf

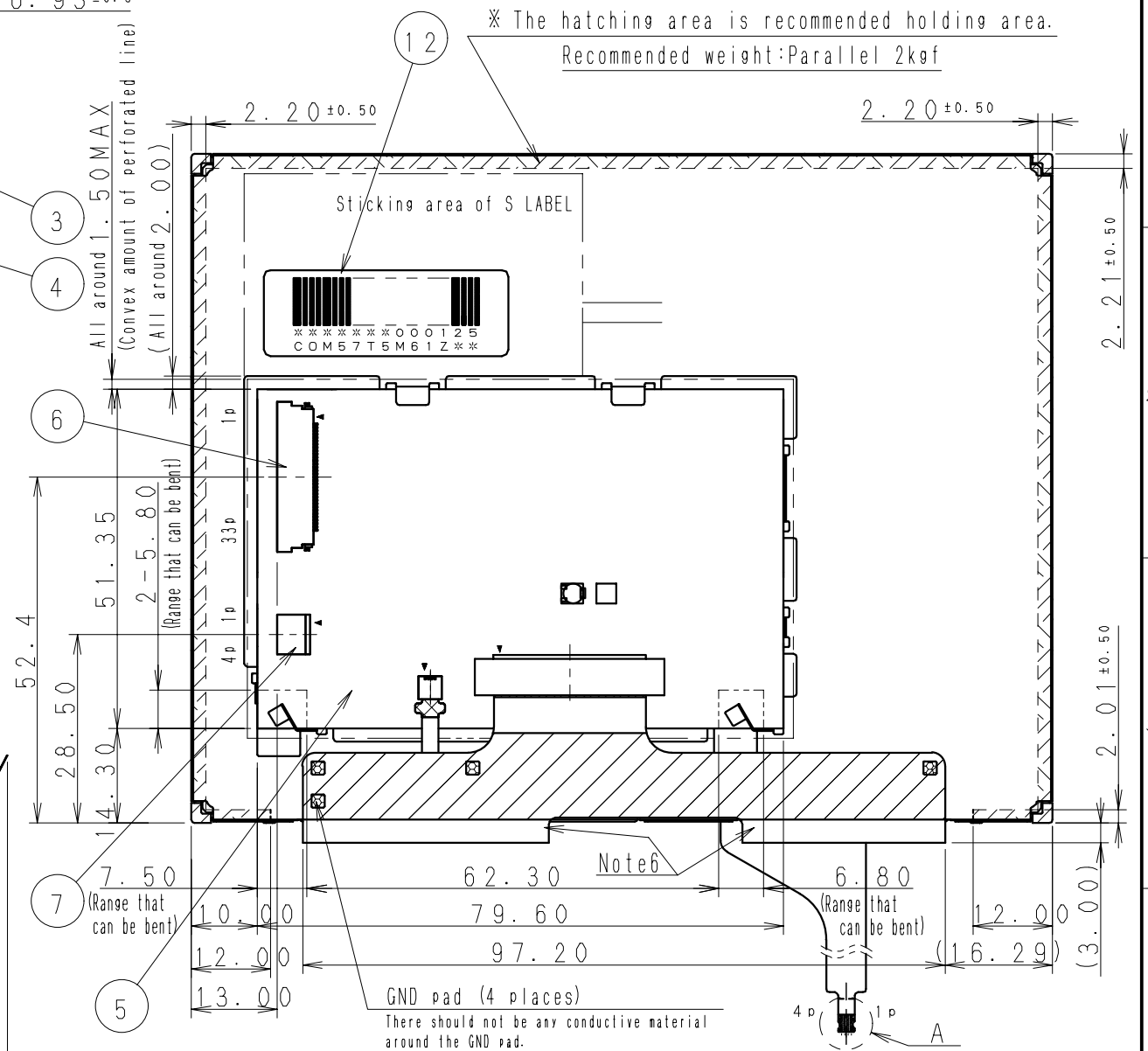

PART NAME	ITEM	MATERIAL GRADE	REMARK
S LABEL	12	Barcode (CODE39)	(37×13×0.075t)
W TAPE	11		(76.60×14.00×0.100t)
I TAPE	10		(83.60×55.35×0.115t)
TOUCH PANEL FPC	9		
TOUCH PANEL	8	Film-Glass (1.1t)	Surface finishing : Anti-Glare
CONNECTOR	7	SM04B-SRSS-G-1B(JST)	pitch1.0x4pin
CONNECTOR	6	04 6240 033 023 846+ (KYOCERA Connector Products)	pitch0.5x33pin
PCB	5		(79.60×51.35×0.8t)
S CASE C	4	SUS	
FRAME	3	PC	
S CASE A	2	SUS	
TFT-LCD PANEL	1	Glass substrate thickness=0.5t	

- Note 1. Angular deviation of LCD cell from the TFT-LCD monitor's reference axis shall be less than [±50'].
- Note 2. S label is affixed the area shown in the drawing. The thickness of the S label will be added to that of S case's surface.
- Note 3. Protective film is affixed on front surface of the screen. Location tolerance of the protective film shall be ±3.0 mm to the TOUCH PANEL.
- Note 4. Recommended FPC connectors
For TP FPC : KYOCERA Connector Products, part number: 04 6277 004 001 883+(Dual-sided contact)
TP FPC pin assignment differs from a position of Datum Pin of recommended FPC connector. Please notice the difference when designing your circuit with much care.
- Note 5. Exercise care not to apply any forces to the cable holder of the S case A.
- Note 6. Exercise care not to apply any forces to the cable.
- Note 7. Indicated area is recommended holding area.
- Note 8. Refer to "12.CRITERIA OF JUDGMENT" about the appearance specification of a polarizer and touch panel.
- Note 9. Linearity is guaranteed in the area surrounded by 3mm inside lines from TOUCH PANEL Active Area.

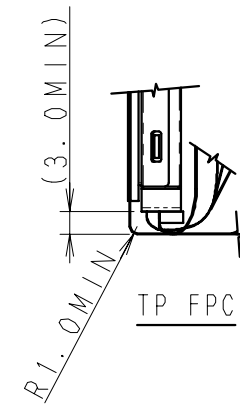

APPROVED Hashizume	GENERAL TOLERANCE ± 1.0	SCALE 1/1	UNIT mm	ORTUSTECH ORTUS TECHNOLOGY CO., LTD. DO NOT DUPLICATE, CONFIDENTIAL AND PROPRIETARY
CHECKED Hiranobu	ISSUE (Y:M:D) 12:07:05	MODEL COM57T5M61Z**		
CHECKED	NAME			DRAWING No. RJD524201D301
DESIGN Ide		OUTLINE-D5M61		REV. SHEET DIV. 1/2
DRAW Ide				PART 6

(7/33)
12TLM021
Issue: Sep. 14, 2012

EC No.	REV.No.	REVISE	DATE (Y:M:D)	APPROVED	CHECKED	PREPARED

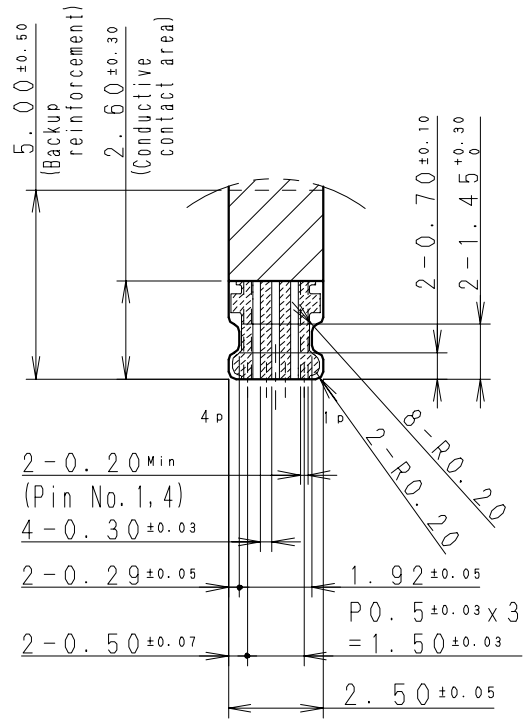

Detail A (S=5/1)

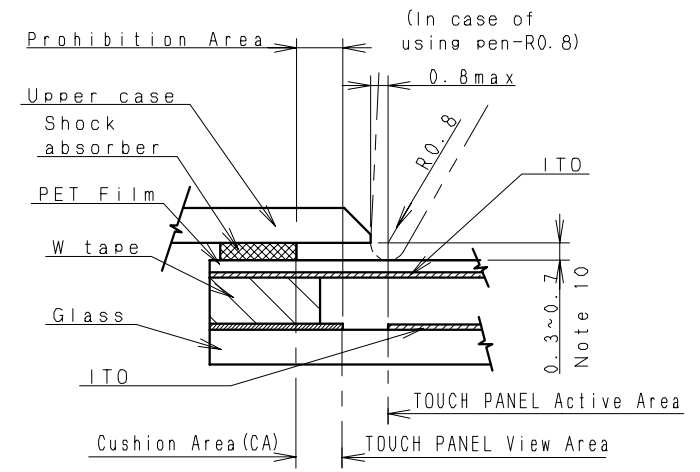

Example of Housing Design (S=Free)

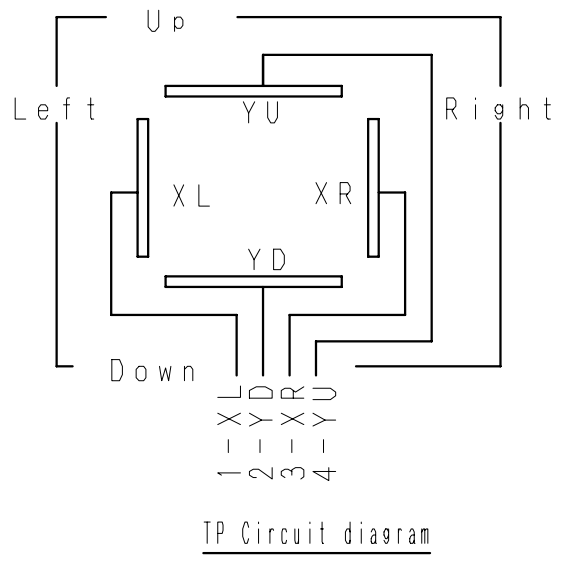

TP Circuit diagram

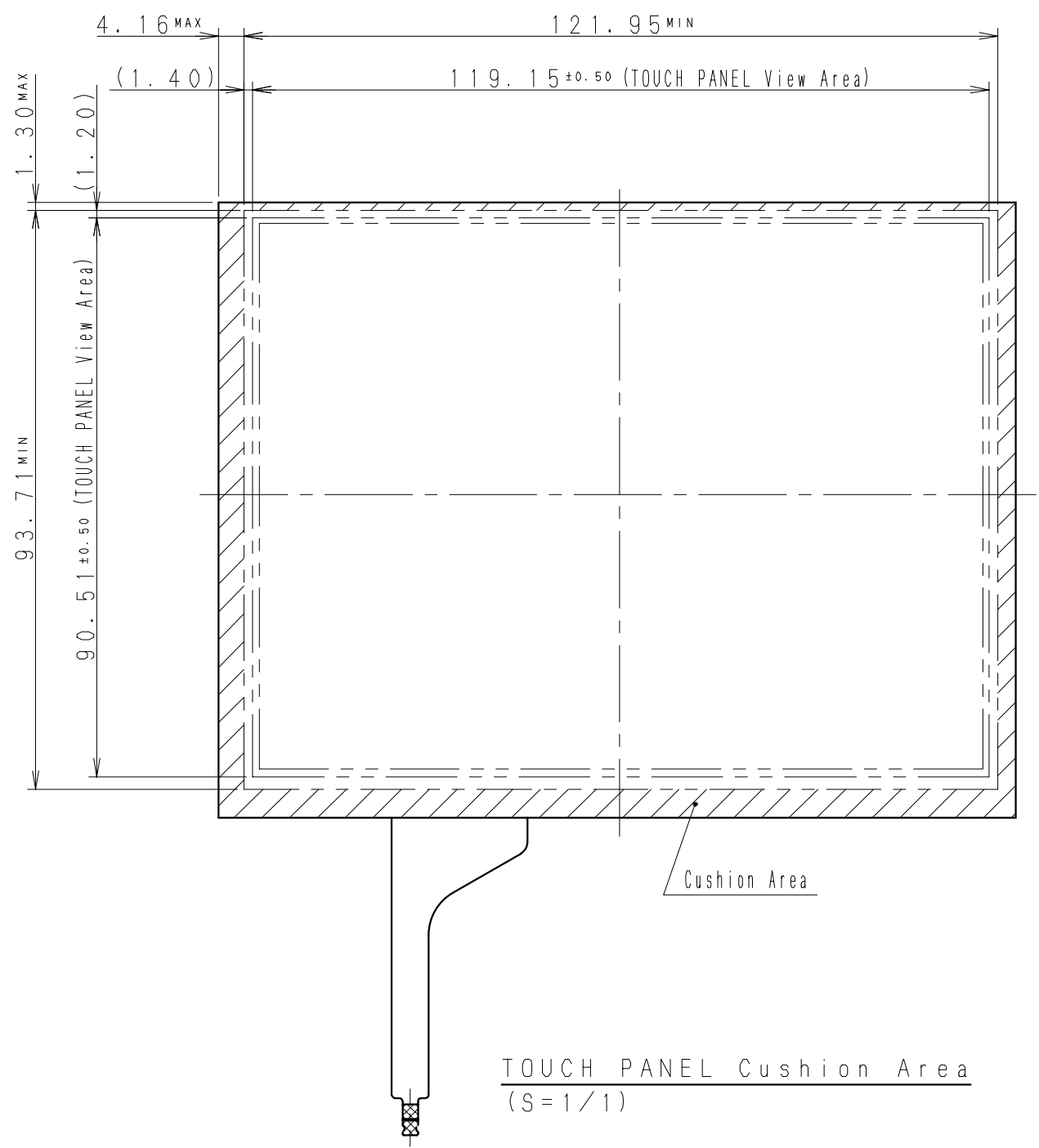

TOUCH PANEL Cushion Area (S=1/1)

Design guidance for the Housing & the cushion

- Note10. Keep a gap, for example 0.3 to 0.7mm between the bezel edge and touch panel surface to avoid the bezel edge from making contacting with the touch panel surface that may cause a "false touch" with the bottom layer.
- Note11. Recommended dimensions of housing in case of using pen(R0.8) (refer to 'Example of Housing Design')
- Note12. Upper case opening
- Please place the upper case opening to maintain the operation by a stylus pen inside the TP response area.
 - The any pressures in the area between TP response area and TP viewing area is prohibited.
- Note13. Cushion design
- Please put the cushion on the upper case.
 - Do not use an adhesive tape to stick on the TP surface.
 - Please position the cushion over the cushion area to avoid a short.

APPROVED Hashizume	GENERAL TOLERANCE ± 1.0	SCALE 1/1 (5/1)	UNIT mm	ORTUSTECH ORTUS TECHNOLOGY CO., LTD. DO NOT DUPLICATE, CONFIDENTIAL AND PROPRIETARY		
CHECKED Hiranobu	ISSUE (Y:M:D) 12:07:05	MODEL COM57T5M61Z**				
CHECKED	NAME			DRAWING No.		
DESIGN Ide	OUTLINE-D5M61			REV.	SHEET	DIV.
DRAW Ide				RJD524201D301	2/2	

3.3 SERIAL LABEL (S-LABEL)

1) Display Items

A section : Bar code

B section : Combination of a character

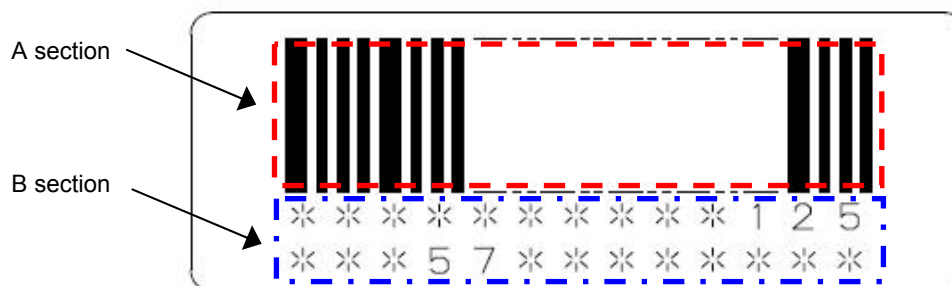

Details of B section

Upper column: It indicates The least significant digit of manufacture year (1 digit),
 manufacture month with below alphabet (1letter), model code (5characters),
 serial number (6digits).

*	*	*****	*****
-	-		
a	b	c	d

Lower column: Model (13characters)

Contents of display													
a	The least significant digit of manufacture year												
b	<table border="1" style="border-collapse: collapse; width: 100%;"> <tr> <td>Jan-A</td> <td>Mar-C</td> <td>May-E</td> <td>Jul-G</td> <td>Sep-I</td> <td>Nov-K</td> </tr> <tr> <td>Feb-B</td> <td>Apr-D</td> <td>Jun-F</td> <td>Aug-H</td> <td>Oct-J</td> <td>Dec-L</td> </tr> </table>	Jan-A	Mar-C	May-E	Jul-G	Sep-I	Nov-K	Feb-B	Apr-D	Jun-F	Aug-H	Oct-J	Dec-L
Jan-A	Mar-C	May-E	Jul-G	Sep-I	Nov-K								
Feb-B	Apr-D	Jun-F	Aug-H	Oct-J	Dec-L								
c	Model code 57DPC (Made in Japan) 57DQC (Made in Malaysia) 57DRC (Made in China)												
d	Serial number												

* Example of indication of Serial label (S-label)

•Made in Japan

2J57DPC000125

means "manufactured in October 2012, 5.7" DP type,
 C specifications, serial number 000125"

•Made in Malaysia

2J57DQC000125

means "manufactured in October 2012, 5.7" DQ type,
 C specifications, serial number 000125"

•Made in China

2J57DRC000125

means "manufactured in October 2012, 5.7" DR type,
 C specifications, serial number 000125"

2) Location of Serial Label (S-label)

Refer to 3.2 "Outward Form".

2) Others

Bar code readability is excluded from quality assurance coverage.

4. Pin Assignment

4.1 Display Module Part

No.	Symbol	Function
1	GND	GND.
2	CLK	Clock signal.Latching data at the falling edge.
3	HSYNC	Horizontal sync signal input.(negative polarity)
4	VSYNC	Vertical sync signal input.(negative polarity)
5	GND	GND.
6	R 0	Display data input for (R). 00h for black display R0:LSB R5:MSB Driver IC carries out gamma conversion internally.
7	R 1	
8	R 2	
9	R 3	
10	R 4	
11	R 5	
12	GND	GND.
13	G 0	Display data input for (G). 00h for black display G0:LSB G5:MSB Driver IC carries out gamma conversion internally.
14	G 1	
15	G 2	
16	G 3	
17	G 4	
18	G 5	
19	GND	GND.
20	B 0	Display data input for (B). 00h for black display B0:LSB B5:MSB Driver IC carries out gamma conversion internally.
21	B 1	
22	B 2	
23	B 3	
24	B 4	
25	B 5	
26	GND	GND.
27	ENAB	Input data effective signal. (It is effective for the period of "Hi")
28	VDD	Power supply input.
29	VDD	Power supply input.
30	RL	Horizontally Flipped (right/left) Signal. (Lo: Horizontally Flipped Display, Hi: Normal display) NOTE1
31	UD	Vertically Flipped (up/down) Signal. (Lo: Normal display,Hi: Vertically Flipped Display) NOTE1
32	DISP	Display on/off control signal.(Lo : display off, Hi : display on) NOTE2
33	GND	GND.

- Used connector : KYOCERA Connector Products 6240 series [04 6240 033 023 846+]
- Please refer to the section "3.2 Outward Form" for pin terminal order.
- The corrosion phenomenon by the different kind metal uniting is generated according to the system requirements, and there is a possibility of becoming a loose connection.
Please select very carefully, and design the FPC cable used.
- NOTE1: If not use , Please let it no connected. NOTE2 : If not use , Please let it connected to VDD.

4.2 Backlight Part

No.	Symbol	Function
1	BLL2	Backlight drive 2 (cathode side).
2	BLL1	Backlight drive 1 (cathode side).
3	BLH2	Backlight drive 2 (anode side).
4	BLH1	Backlight drive 1 (anode side).

- Used connector: JST [SM04B-SRSS-G-TB(LF)(SN)]
- Please refer to the section "3.2 Outward Form" for pin terminal order.
- The corrosion phenomenon by the different kind metal uniting is generated according to the system requirements, and there is a possibility of becoming a loose connection.
Please select very carefully, and design the contact used.

4.3 Touch Panel Part

No.	Symbol	Function
1	(XL)	(X-axis left terminal)
2	(YD)	(Y-axis downside terminal)
3	(XR)	(X-axis right terminal)
4	(YU)	(Y-axis upside terminal)

- Recommended connector : KYOCERA Connector Products 6277 series [04 6277 004 001 883+]
- Please make sure to check a consistency between pin assignment in "3.2 Outward Form" and your connector pin assignment when designing your circuit.
Inconsistency in input signal assignment may cause a malfunction.
- Since FPC cable has gold plated terminals, gilt finish contact shoe connector is recommended.

5. Block Diagram

Each arrow shows signal flow.

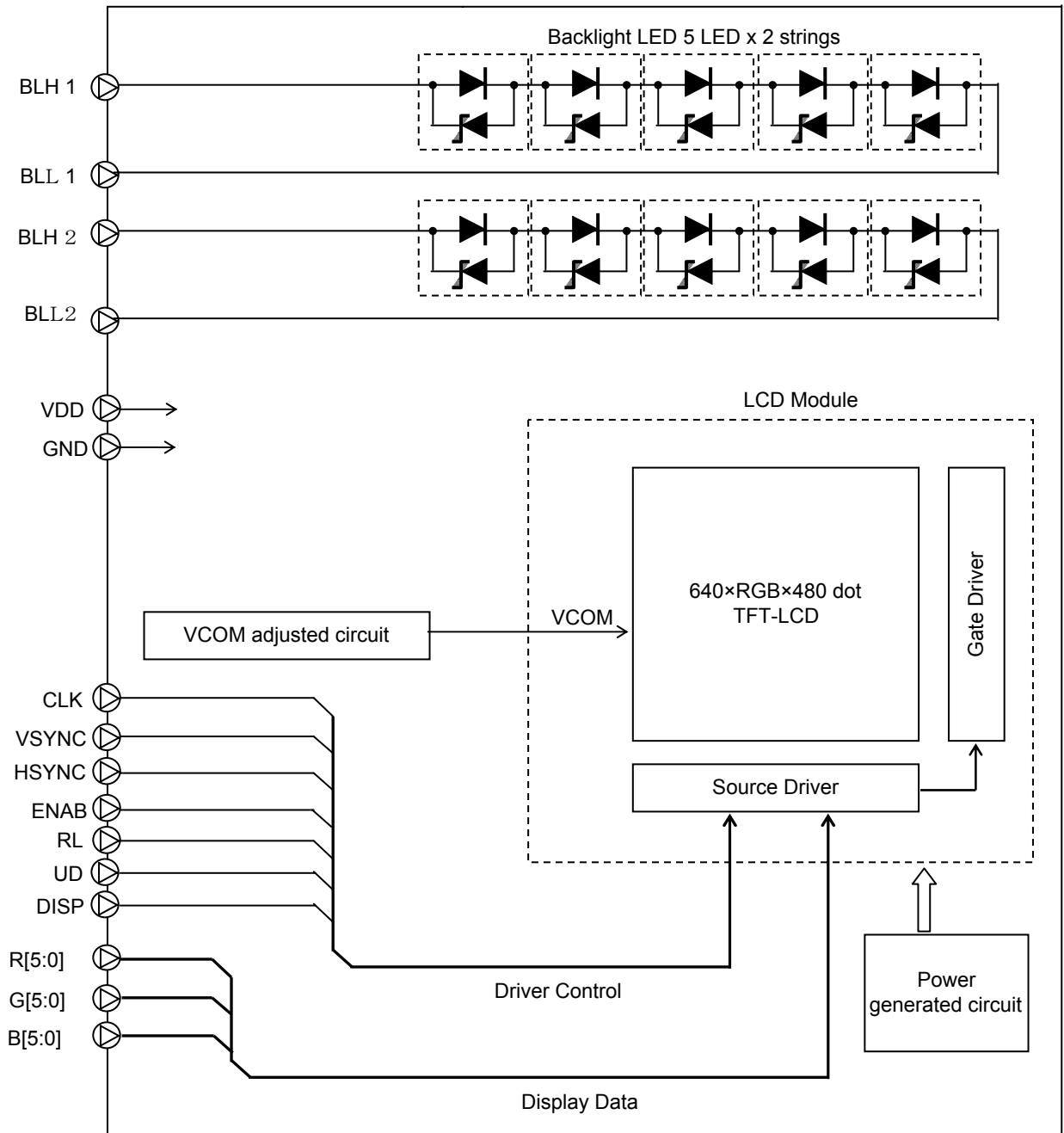

6. Absolute Maximum Rating

VSS=0V

Item	Symbol	Condition	Rating		Unit	Applicable terminal	
			MIN	MAX			
Supply voltage	VDD	Ta=25°C	-0.3	6.0	V	VDD	
Input voltage for logic	VI		-0.3	VDD+0.3	V	CLK, VSYNC, HSYNC, ENAB, B[5:0], G[5:0], R[5:0], RL, UD, DISP	
LED forward current	IL		--	70	mA	BLH1-BLL1, BLH2-BLL2	
Input voltage for Touch Panel	VIT		--	7.0	V	XR, XL, YU, YD	
Storage temperature range	Tstg		-30	80	°C		
Storage humidity range	Hstg	Non condensing in an environmental moisture at or less than 40°C90%RH.					

Note: Please input the logic signal after turning on VDD. Do not input the logic signal while blocking VDD.

Absolute maximum ratings is parametric values, should never be exceed any value at any moment.

Beyond which, it could be suffered from changes in characteristics and never be restored.

Moreover, it could even be suffered from permanent destruction.

Therefore, please note enough the fluctuation of input voltage, the characteristics of connected parts,

I/O signal line surge, and ambient temperature, on designing the circuit.

7. Recommended Operating Conditions

VSS=0V

Item	Symbol	Condition	Rating			Unit	Applicable terminal
			MIN	TYP	MAX		
Supply voltage	VDD		3.0	3.3	3.6	V	VDD
Input voltage for logic	VI	VDD=3.0~3.6V	0	--	VDD	V	CLK, VSYNC, HSYNC, B[5:0], G[5:0], R[5:0], ENAB, RL, UD, DISP
Operating temperature range	Top	Note1,2	-20	25	70	°C	Touch panel surface temperature
Operating humidity range	Hop	Ta ≤ 40°C	20	--	85	%	
		Ta > 40°C	Non condensing in an environmental moisture at or less than 40°C85%RH.				

Note1: The temperature within the display will increase due to the heat radiated from the back light while in operation.

Necessary measures have to be taken in the product design to make sure that the display has proper ventilation so that temperature on any surface of this display should not exceed 70°C.

Note2: This monitor is operatable in this temperature range. With regard to optical characteristics, refer to Item "10. CHARACTERISTICS".

8. Characteristics

8.1 DC Characteristics

8.1.1 Display Module

(Unless otherwise noted, Ta=25°C, VDD=3.3V, VSS=0V)

Item	Symbol	Condition	Rating			Unit	Applicable terminal
			MIN	TYP	MAX		
Input voltage for logic	VIH		0.7×VDD	--	VDD	V	CLK, VSYNC, HSYNC, ENAB, B[5:0], G[5:0],
	VIL		0	--	0.3×VDD	V	R[5:0], RL, UD, DISP
Pull down resistor value	Rpd		300	450	600	kΩ	ENAB, B[5:0], G[5:0], R[5:0]
Pull up resistor value	Rpu		300	450	600	kΩ	DISP
Current consumption	IDD	fCLK=25MHz Color bar display	--	140	280	mA	VDD

8.1.2 Backlight

Item	Symbol	Condition	Rating			Unit	Applicable terminal
			MIN	TYP	MAX		
Forward current	IL	Ta=25°C	--	50	70	mA	BLH1 – BLL1
Forward voltage	VL	Ta=25°C, IL= 50 mA	--	15.0	17.0	V	BLH2 – BLL2
Estimated Life of LED	LL	Ta=25°C, IL= 50 mA Note	--	70,000	--	hr	

Note: - The lifetime of the LED is defined as a period till the brightness of the LED decreases to the half of its initial value.

- This figure is given as a reference purpose only, and not as a guarantee.
- This figure is estimated for an LED operating alone.

As the performance of an LED may differ when assembled as a monitor together with a TFT panel due to different environmental temperature.

- Estimated lifetime could vary on a different temperature and usually higher temperature could reduce the life significantly.

8.1.3 Touch Panel

Ta=25°C

Item	Symbol	Condition	Rating			Unit	Applicable terminal
			MIN	TYP	MAX		
Linearity	LE	Note	--	--	±1.5	%	
Insulation resistance	RI	DC 25V	20	--	--	MΩ	XR,XL-YU,YD
Terminal resistance		X	200	--	900	Ω	XR,XL
		Y	100	--	800		YU,YD
Rated voltage		DC	--	5.0	7.0	V	XR,XL,YU,YD
on/off chattering		R0.8mm Polyacetal pen.	--	--	10	ms	

Note: -Please refer to "3.2 Outward Form" for the range of the guarantee.

-Linearity Measurement:Refer to the APPENDIX of "Reference Method for Measuring Optical Characteristics".

Load:2.45N

Mechanical Characteristics

Item	Rating			Unit	Remark
	MIN	TYP	MAX		
Detectable activation force	0.1	--	0.8	N	(R0.8mm Polyacetal pen or finger. Resistance between X and Y axis must be equal or lower than 2KΩ.)
Keystroke durability	1,000,000	--	--	times	(key the same part by silicon rubber.) (Touch panel Active area only) ('-Rubber tip part: R8mm) ('-Load: 2.45N) ('-speed: 2times/second)

8.2 AC Characteristics
8.2.1 Display Module

(Unless otherwise noted, Ta=25°C,VDD=3.3V,VSS=0V)

Item	Symbol	Condition	Rating			Unit	Applicable terminal
			MIN	TYP	MAX		
CLK frequency	fCLK		--	25	27	MHz	CLK
CLK Low period	tw1L	0.3×VDD or less	14.8	--	--	ns	CLK
CLK High period	tw1H	0.7×VDD or more	14.8	--	--	ns	CLK
Setup time	tsp		10	--	--	ns	CLK,ENAB,B[5:0],
Hold time	thd		10	--	--	ns	G[5:0],R[5:0], HSYNC,VSYNC

Switching Waveform Characteristics

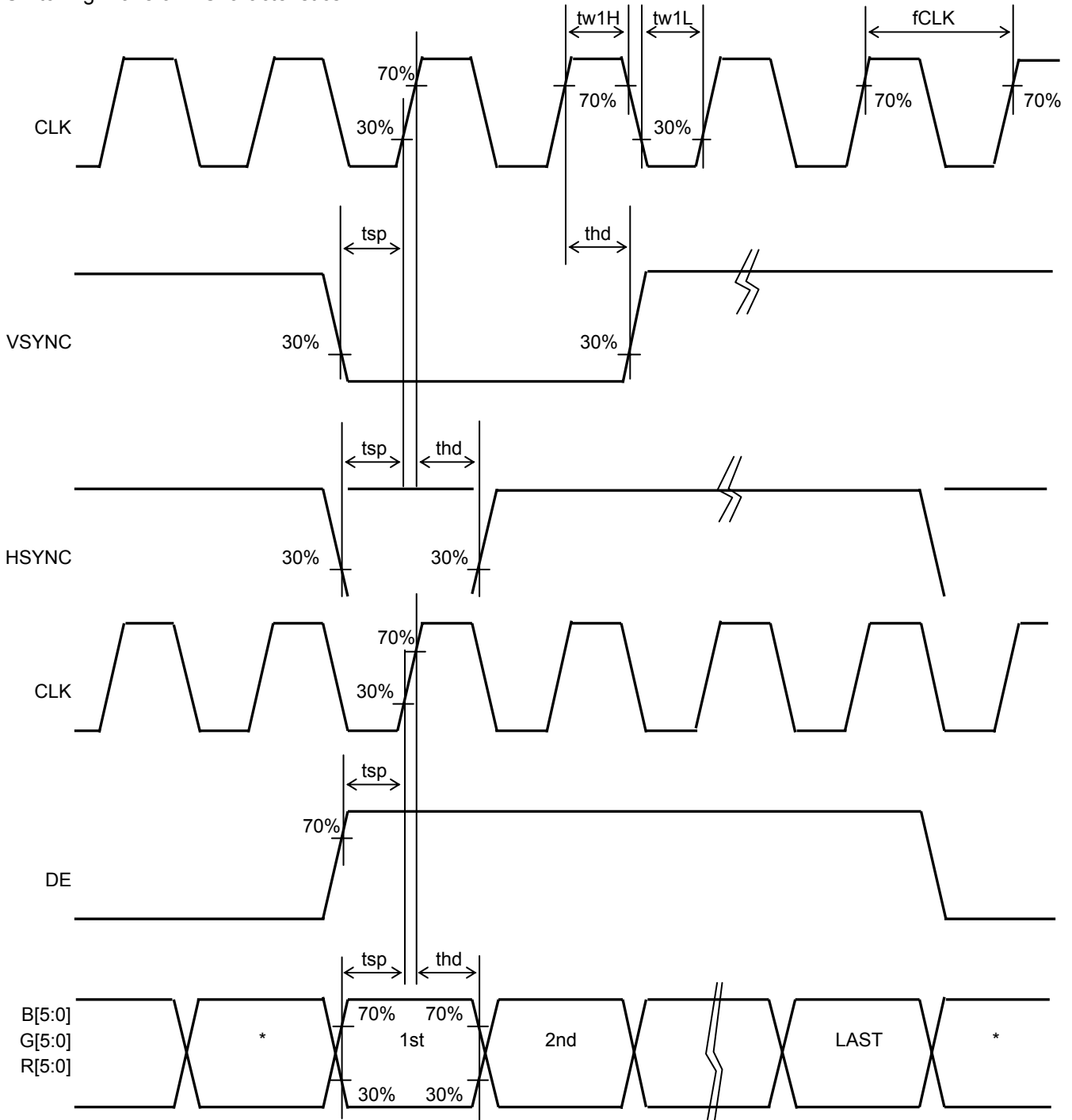

*:INVALID

8.3 Input Timing Characteristics

Item	Symbol	Rating			Unit	Applicable terminal
		MIN	TYP	MAX		
CLK frequency	fCLK	--	25	27	MHz	CLK
VSYNC signal cycle time	tv	--	525	--	H	VSYNC,HSYNC
VSYNC frequency	fVSYNC	54	60	66	Hz	VSYNC
VSYNC pulse width	tw2H	1	3	5	H	VSYNC,HSYNC
Vertical back porch	tvb	--	35	--	H	VSYNC,HSYNC,ENAB,B[5:0],
Vertical display period	tvdp	--	480	--	H	G[5:0],R[5:0]
HSYNC signal cycle time	th	--	800	--	CLK	HSYNC,CLK
HSYNC pulse width	tw3H	5	30	--	CLK	
Horizontal back porch	thb	112	--	144	CLK	HSYNC,CLK,ENAB,B[5:0],
				Note 2		G[5:0],R[5:0]
Horizontal display period	thdp	--	640	--	CLK	
DE pulse width	tw4H	--	640	--	CLK	ENAB,CLK

Note1: The characteristic of this item is recommended standard.

Please use it after it confirms it enough like the display fineness etc.

When it comes off from this characteristic and it is used.

Note2: When "ENAB" keeps "Lo" for 144CLK or longer,start capturing data automatically from 144CLK.

8.4 Driving Timing Chart

-Vertical Timing

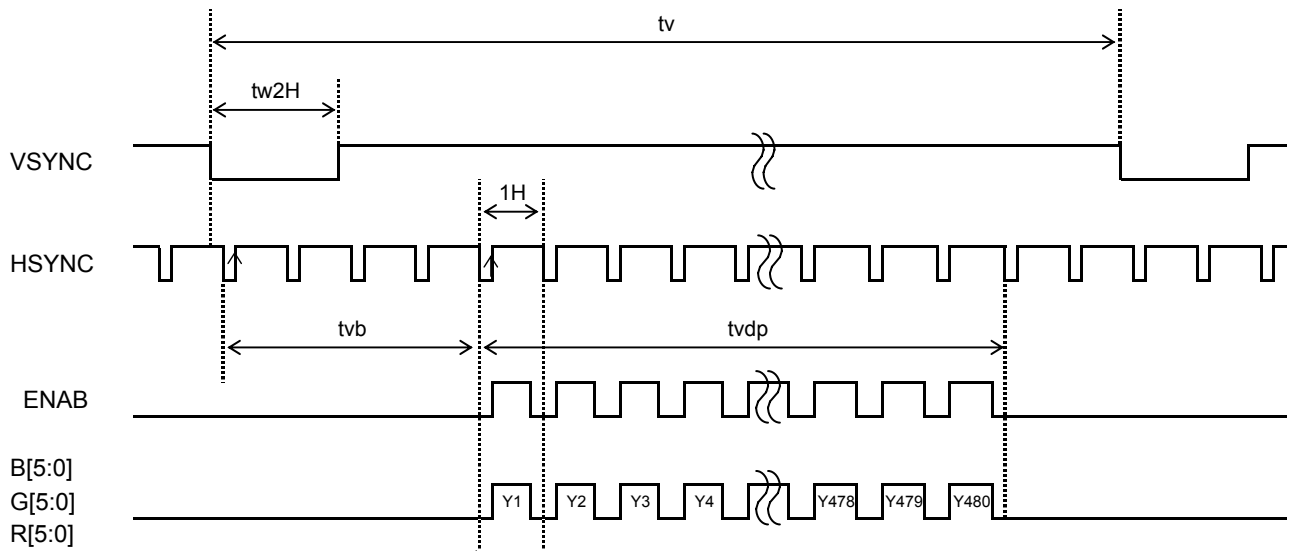

-Horizontal Timing

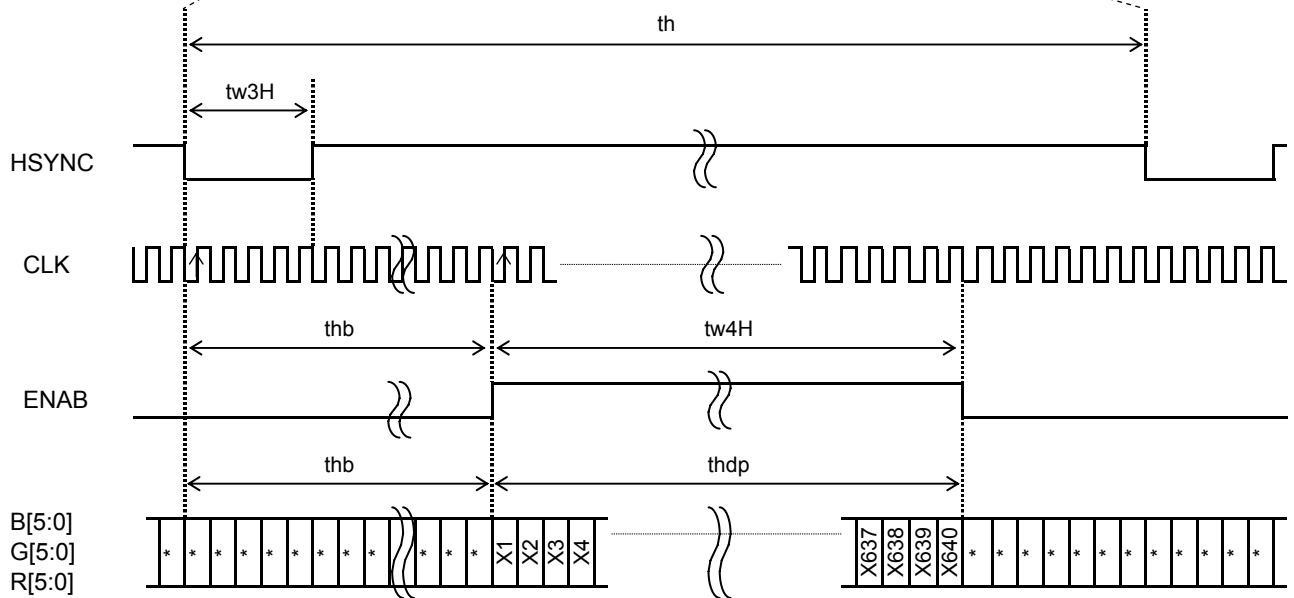

8.5 Example of Driving Timing Chart (fCLK=25MHz)

-Vertical Timing

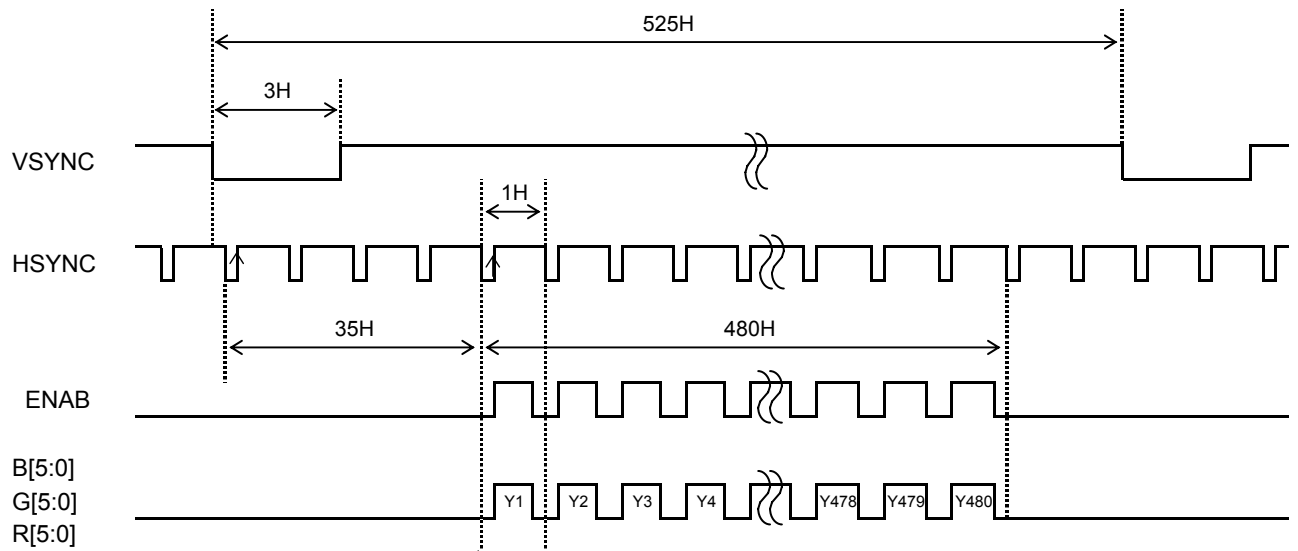

-Horizontal Timing

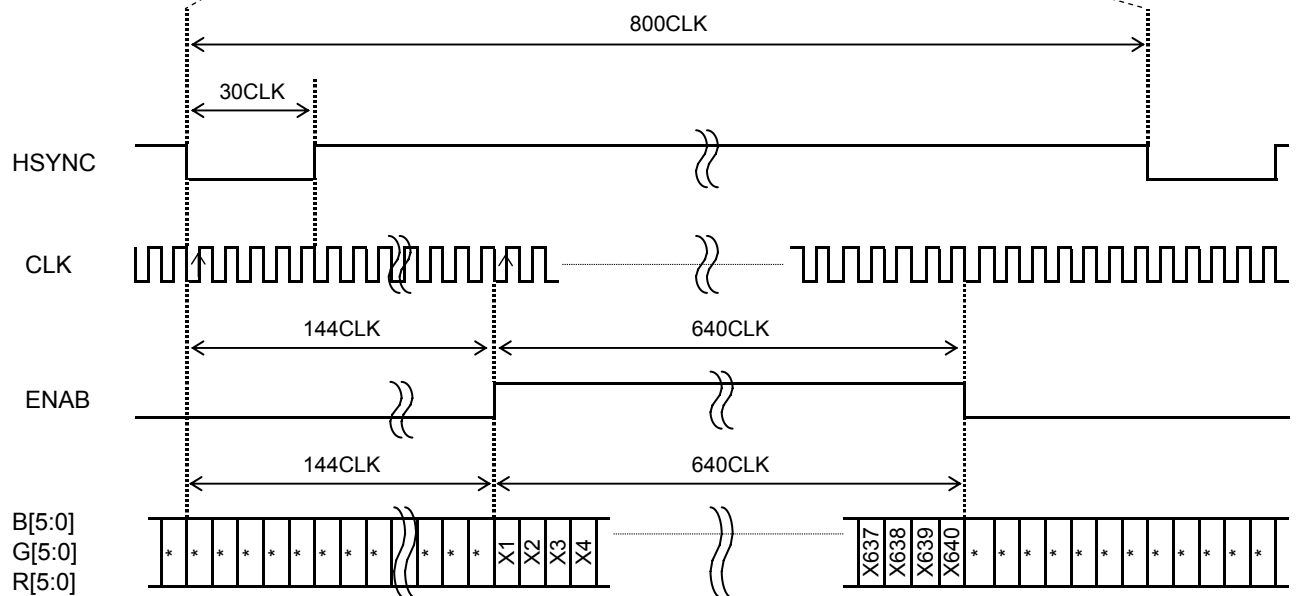

9. "DISP" on/off Sequence

It explains the Display on/off sequence.

After Display on, "White" data is outputted for 16-Frames first, from the falling edge of the following VSYNC signal.

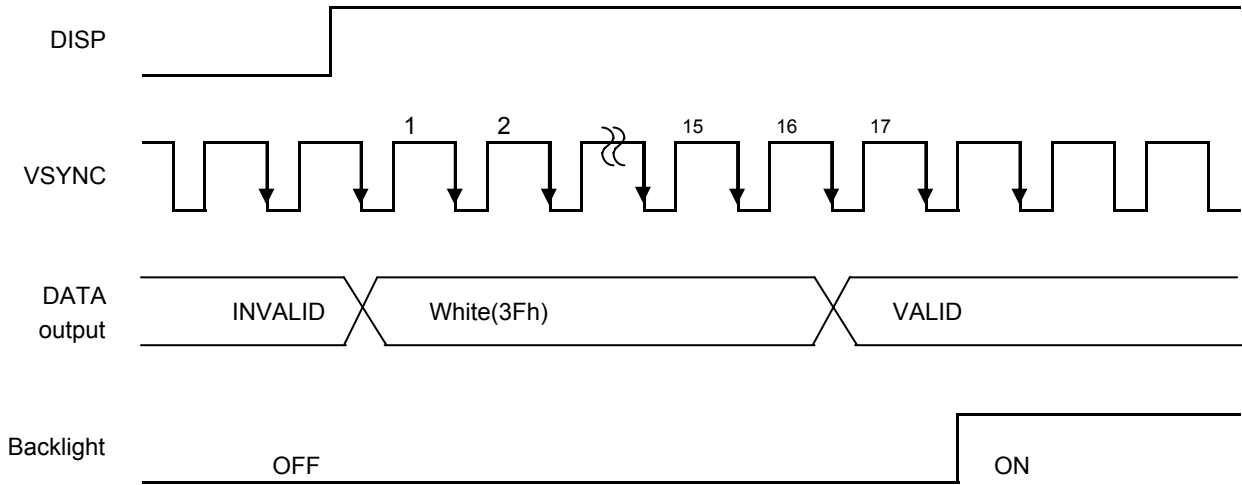

After Display off, "White" data is outputted for 5-Frames first, from the falling edge of the following VSYNC signal. Please turn off the power supply promptly after OFF of "DISP".

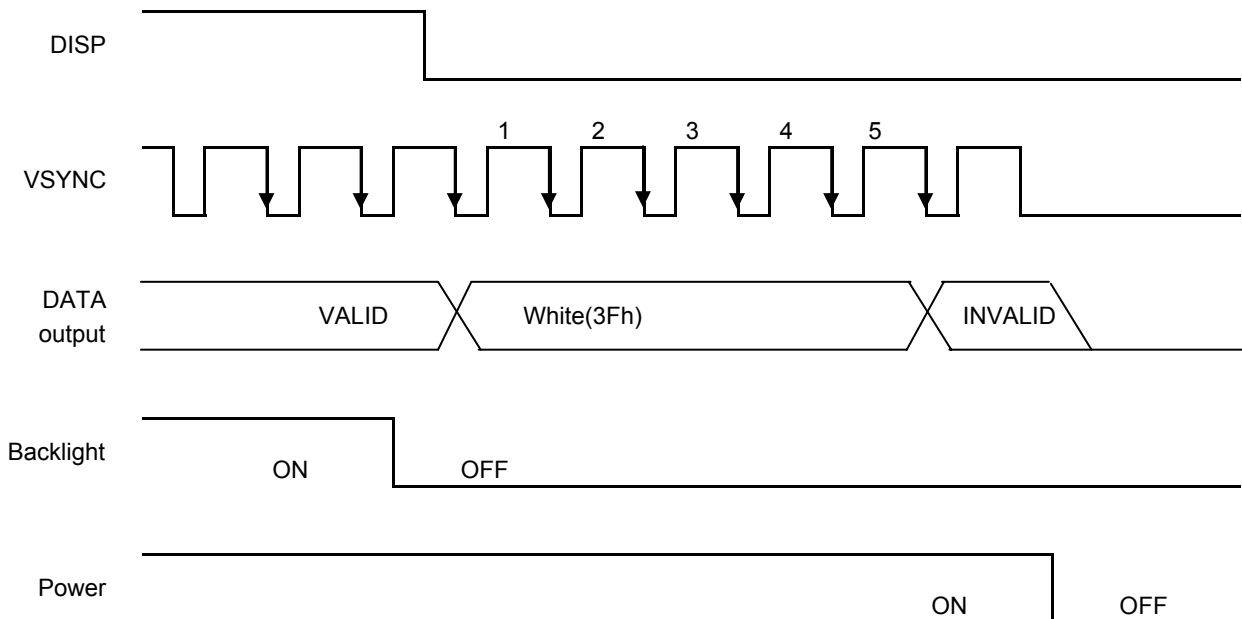

10. Touch Panel Circuit

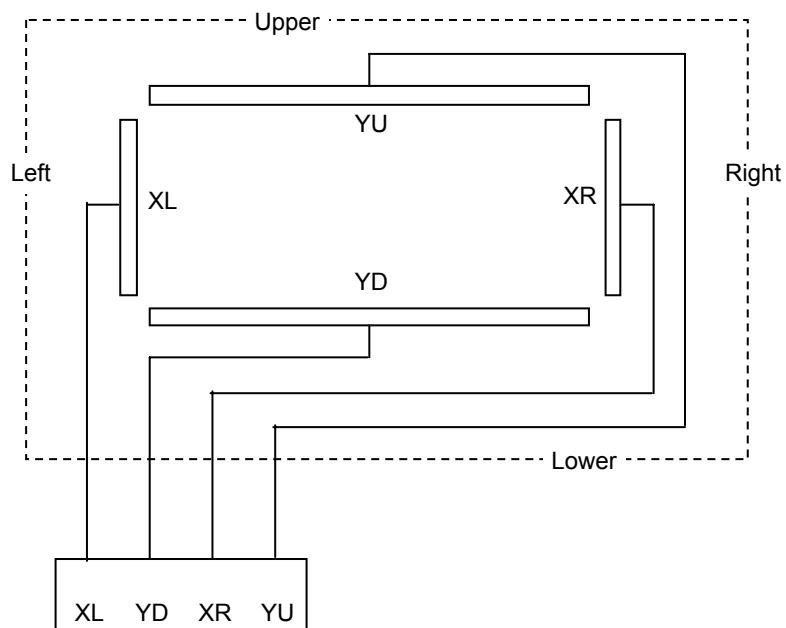

11. Characteristics

11.1 Optical Characteristics

< Measurement Condition >

Measuring instruments: CS1000 (KONICA MINOLTA), LCD7000(OTSUKA ELECTRONICS),
EZcontrast160D (ELDIM)

Driving condition: VDD = 3.3V, VSS = 0V
Optimized VCOMDC

Backlight: IL=50mA

Measured temperature: Ta=25°C

Item	Symbol	Condition	MIN	TYP	MAX	Unit	Note No.	Remark
Response time	Rise time	TON	[Data]= 3Fh→00h	—	—	40	ms	1 ※
	Fall time	TOFF	[Data]= 00h→3Fh	—	—	60	ms	
Contrast ratio	CR	[Data]= 3Fh/00h	360	700	—		2	
Viewing angle	Left	θL	[Data]= 3Fh/00h	80	—	—	deg	3 ※
	Right	θR		80	—	—	deg	
	Up	φU	CR ≥ 10	55	—	—	deg	
	Down	φD		80	—	—	deg	
White Chromaticity	x	[Data]=3Fh	White chromaticity range				4	
	y							
Burn-in			No noticeable burn-in image should be observed after 0.5 hours of window pattern display.				5	
Center brightness		[Data]=3Fh	160	350	—	cd/m ²	6	
Brightness distribution		[Data]=3Fh	70	—	—	%	7	

* Note number 1 to 7: Refer to the APPENDIX of "Reference Method for Measuring Optical Characteristics".

※ Measured in the form of LCD module.

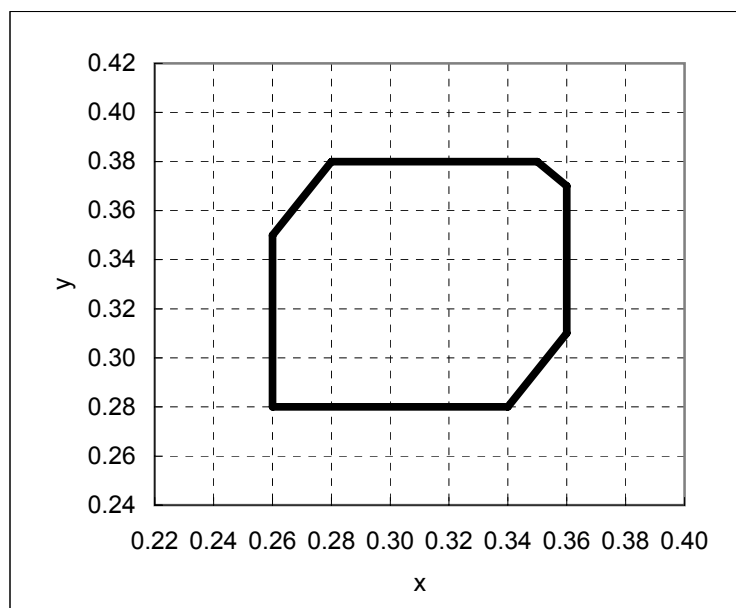

White Chromaticity Range

【White Chromaticity Range】

x	y
0.26	0.35
0.26	0.28
0.34	0.28
0.36	0.31
0.36	0.37
0.35	0.38
0.28	0.38

11.2 Temperature Characteristics

< Measurement Condition >

Measuring instruments: CS1000 (KONICA MINOLTA), LCD7000(OTSUKA ELECTRONICS)

Driving condition: VDD = 3.3V, VSS = 0V

Optimized VCOMDC

Backlight: IL=50mA

Item		Specification		Remark	
		Ta = -10°C	Ta = 70°C		
Contrast ratio	CR	40 or more	40 or more		
Response time	Rise time	TON	200 msec or less	30 msec or less	※
	Fall time	TOFF	300 msec or less	50 msec or less	※
Display Quality		No noticeable display defect or nonuniformity should be observed.		Use the criteria for judgment specified in the section 12.	

※ Measured in the form of LCD module.

12. Criteria of Judgment

12.1 Defective Display and Screen Quality

Test Condition:	Observed TFT-LCD monitor from front during operation with the following conditions
Driving Signal	Raster Patter (RGB in monochrome, white, black)
Signal condition	[Data] : 3Fh, 15h, 00h (3 steps)
Observation distance	30 cm
Illuminance	200 to 350 lx
Backlight	IL=50mA

Defect item	Defect content	Criteria		
Display Quality	Line defect	Black, white or color line, 3 or more neighboring defective dots		
	Dot defect	Uneven brightness on dot-by-dot base due to defective TFT or CF, or dust is counted as dot defect (brighter dot, darker dot) High bright dot: Visible through 2% ND filter at [Data]=00h Low bright dot: Visible through 5% ND filter at [Data]=00h Dark dot: Appear dark through white display at [Data]=15h		
Screen Quality	Dirt	Point-like uneven brightness (white stain, black stain etc)		
	Foreign particle	Point-like	$0.25\text{mm} < \varphi$	
			$0.20 < \varphi \leq 0.25\text{mm}$	
			$\varphi \leq 0.20\text{mm}$	
	Liner	Liner	$3.0\text{mm} < \text{length and } 0.08\text{mm} < \text{width}$	
			$\text{length} \leq 3.0\text{mm or width} \leq 0.08\text{mm}$	
	Flaw	Flaw on the surface of the Touch panel	$0.05\text{mm} < W$	
			$0.03 < W \leq 0.05\text{mm}$	$2 < L \leq 5\text{mm}$
				$L \leq 2\text{mm}$
			$W \leq 0.03\text{mm}$	
Others		Use boundary sample for judgment when necessary		

$\varphi(\text{mm})$: Average diameter = (major axis + minor axis)/2
Permissible number: N

Table 1

Area	High bright dot	Low bright dot	Dark dot	Total	Criteria
A	0	2	2	3	Permissible distance between same color bright dots (includes neighboring dots): 3 mm or more Permissible distance between same color high bright dots (includes neighboring dots): 5 mm or more
B	2	4	4	6	
Total	2	4	4	7	

<Landscape model>

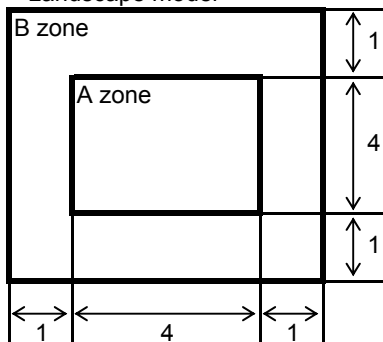

Division of A and B areas

B area: Active area

Dimensional ratio between A and B areas: 1: 4: 1 (Refer to the left figure)

12.2 Screen and Other Appearance

Testing conditions

Observation distance	30cm
Illuminance	1200~2000 lx

Item	Criteria	Remark
Polarizer Flaw Stain Bubble Dust Dent	Ignore invisible defect when the backlight is on.	Applicable area: Active area only (Refer to the section 3.2 "Outward form")
S-case	No functional defect occurs	
FPC cable	No functional defect occurs	

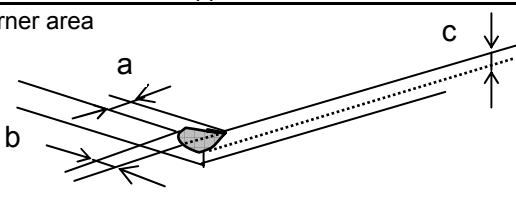
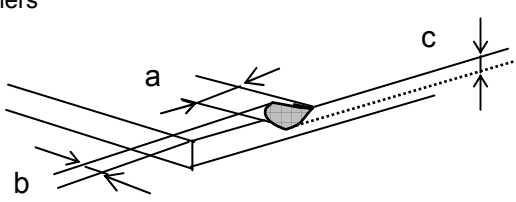
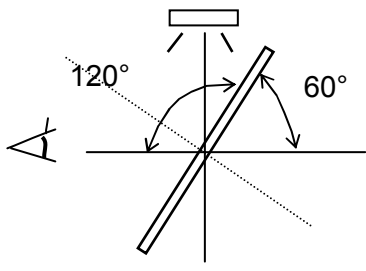
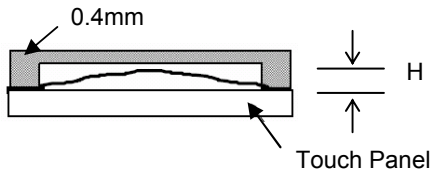
Item	Appearance	Criteria
Touch Panel	Corner area 	Unit:mm $a \leq 3$ $b \leq 3$ $c \leq t$ (t: glass thickness) $a, b \leq 0.5$ is ignored $n \leq 2$
	Others 	Unit:mm $a \leq 5$ $b \leq 1$ $c \leq t$ (t:glass thickness) $a, b \leq 0.5$ is ignored Maximum permissible number of chipping off on a side is 5.
	Progressive crack	None
	Interference fringe (Test method) Observe the Panel surface from 60 degrees angle to the surface under white fluorescent lamp (Triple wavelength lamp) 	Size: 1/3 or less of Active area. Darkness: comply with the boundary sample.
Puffiness 	$H \leq 0.4\text{mm}$ is acceptable.	

13. Reliability Test

Test item	Test condition	number of failures /number of examinations
Durability test	High temperature storage	Ta=80°C 240H 0/3
	Low temperature storage	Ta=-30°C 240H 0/3
	High temperature & high humidity storage	Ta=60°C, RH=90% 240H 0/3 non condensing ※
	High temperature operation	Tp=70°C 240H 0/3
	Low temperature operation	Tp=-20°C 240H 0/3
	High temp & humid operation	Tp=40°C, RH=90% 240H 0/3 non condensing ※
	Thermal shock storage	-30↔80°C(30min0/30min) 100 cycles 0/3
Mechanical environmental test	Surface discharge test (Non operation)	C=250pF, R=100Ω, V=±12kV Each 5 times of discharge in both polarities on the center of screen with the case grounded. 0/3
	Vibration test	Total amplitude 1.5mm, f=10~55Hz, X,Y,Z directions for each 2 hours 0/3
	Impact test	Use ORTUS TECHNOLOGY original jig (see next page)and make an impact with peak acceleration of 1000m/s ² for 6 msec with half sine-curve at 3 times to each X, Y, Z directions in conformance with JIS C 60068-2-27-2011. 0/3
Packing test	Packing vibration-proof test	Acceleration of 19.6m/s ² with frequency of 10→55→10Hz, X,Y, Zdirection for each 30 minutes 0/1 Packing
	Packing drop test	Drop from 75cm high. 1 time to each 6 surfaces, 3 edges, 1 corner 0/1 Packing

Note: Ta=ambient temperature Tp=Panel temperature

※ The profile of high temperature/humidity storage and High Temperature/humidity operation
(Pure water of over 10MΩ·cm shall be used.)

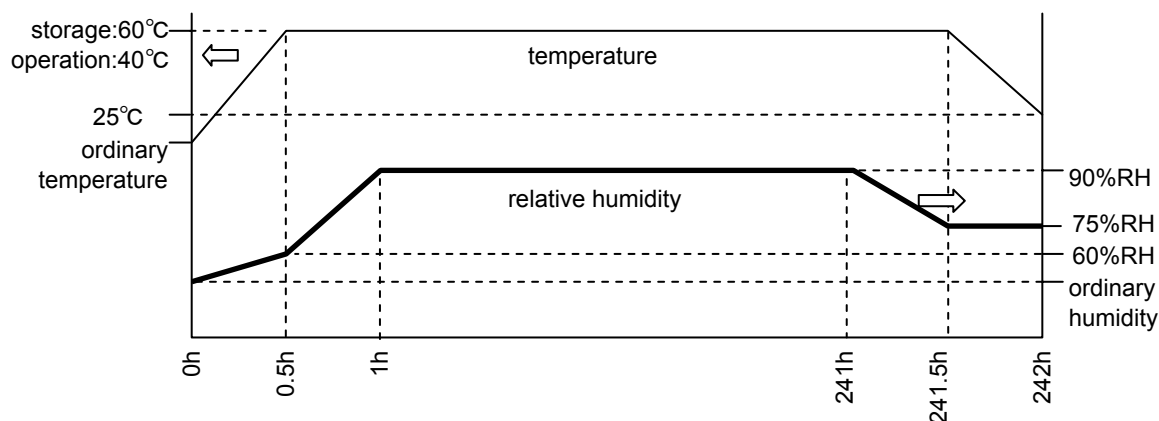
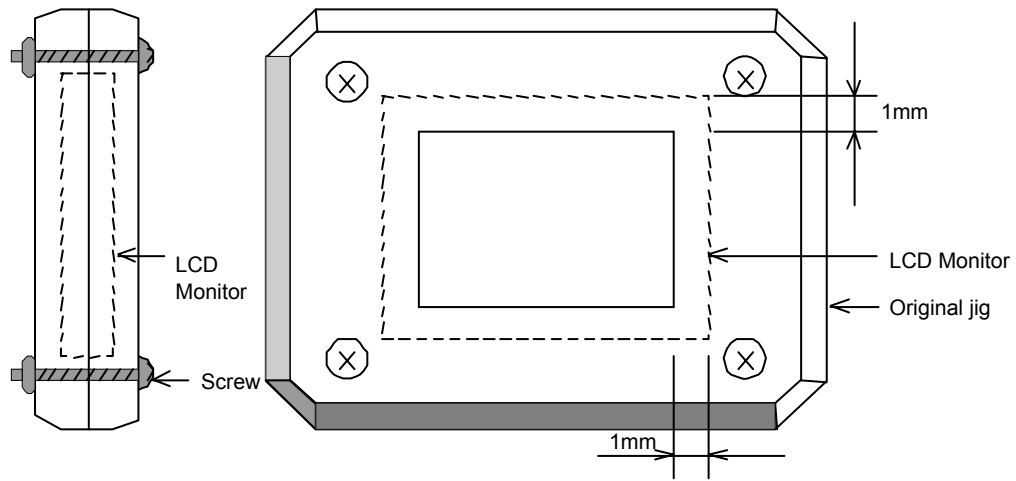

Table2.Reliability Criteria

The parameters should be measured after leaving the monitor at the ordinary temperature for 24 hours or more after the test completion.

item	Standard	Remarks
Display quality	No visible abnormality shall be seen.	
Contrast ratio	40 or more	

ORTUS TECHNOLOGY Original Jig



14. Packing Specifications

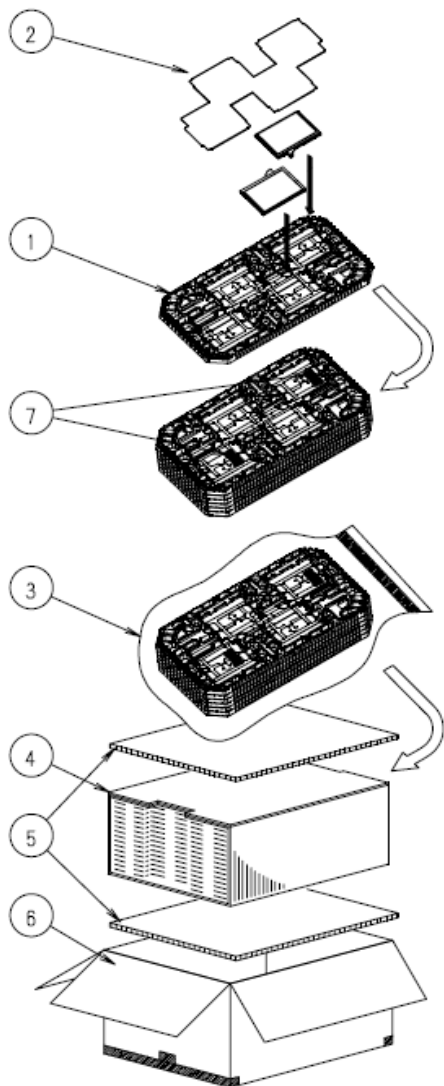

- Step 1. Each product is to be placed in one of the cut-outs of the tray with the display surface facing upward.(4products per tray)
Antistatic foam sheet is to be placed on the products in the tray.
- Step 2. Each tray needs to be same orientation respect to the tray below or above it and the trays be in a stack of 5.
One empty tray is to be put on the top of stack of 5 trays.
- Step 3. 2 packs of moisture absorbers are to be placed on the top tray as shown in the drawing.
Put piled trays into a sealing bag.
Vacuum and seal the sealing bag with the vacuum sealing machine.
- Step 4. The stack of trays in the plastic back is to be inserted into a inner carton.
- Step 5. A corrugated board is to be placed on the top and on the bottom of the inner carton.
The two corrugated boards and the inner carton is to be inserted into an outer carton.
- Step 6. The outer carton needs to sealed with packing tape as shown in the drawing.
The model number, quantity of products, and shipping date are to be printed on the outer carton.
If necessary, shipping labels or impression markings are to be put on the outer carton.
- Step 7. The outer carton is to be inserted into a extra outer carton with same direction.
The extra outer carton needs to sealed with packing tape as shown in the drawing.
- Step 8. The model number, quantity of products, and shipping date are to be printed on the extra outer carton.
If necessary, shipping labels or impression markings are to be put on the extra outer carton.

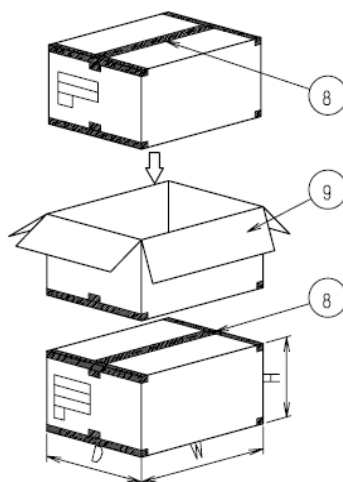

Remark: The return of packing materials is not required.

Packing item name		Specs., Material
①	TRAY	A-PET(Antistatic)
②	FOAM SHEET	Anti-static polyethylene
③	SEALING BAG	
④	INNER CARTON	Corrugated cardboard
⑤	INNER BOARD	Corrugated cardboard
⑥	OUTER CARTON	Corrugated cardboard
⑦	Drier	Moisture absorber
⑧	Packing tape	
⑨	EXTRA OUTER CARTON	Corrugated cardboard

Dimension of extra outer carton	
D : Approx.	(338mm)
W : Approx.	(549mm)
H : Approx.	(198mm)
Quantity of products packed in one carton:	4pcsx5=20pcs
Gross weight : Approx.	6.5kg

15. Handling Instruction

15.1 Cautions for Handling LCD panels

**Caution**

- (1) Do not make an impact on the LCD panel glass because it may break and you may get injured from it.
- (2) If the glass breaks, do not touch it with bare hands.
(Fragment of broken glass may stick you or you cut yourself on it.)
- (3) If you get injured, receive adequate first aid and consult a medial doctor.
- (4) Do not let liquid crystal get into your mouth.
(If the LCD panel glass breaks, try not let liquid crystal get into your mouth even toxic property of liquid crystal has not been confirmed.)
- (5) If liquid crystal adheres, rinse it out thoroughly.
(If liquid crystal adheres to your cloth or skin, wipe it off with rubbing alcohol or wash it thoroughly with soap. If liquid crystal gets into eyes, rinse it with clean water for at least 15 minutes and consult an eye doctor.)
- (6) If you scrap this products, follow a disposal standard of industrial waste that is legally valid in the community, country or territory where you reside.
- (7) Do not connect or disconnect this product while its application products is powered on.
- (8) Do not attempt to disassemble or modify this product as it is precision component.
- (9) If a part of soldering part has been exposed, and avoid contact (short-circuit) with a metallic part of the case etc. about FPC of this model, please.
Please insulate it with the insulating tape etc. if necessary.
The defective operation is caused, and there is a possibility to generation of heat and the ignition.
- (10) Since excess current protection circuit is not built in this TFT module, there is the possibility that LCD module or peripheral circuit become feverish and burned in case abnormal operation is generated.
We recommend you to add excess current protection circuit to power supply.
- (11) The end part of glass and film of touch panel has conductivity, and avoid contact (short-circuit) with electroconductive case etc.. There is a possibility of setting up a defective touch panel, and insulate it for the case suppression (cushion etc.) if necessary, please.

**Caution**

This mark is used to indicate a precaution or an instruction which, if not correctly observed, may result in bodily injury, or material damages alone.

15.2 Precautions for Handling

- 1) Wear finger tips at incoming inspection and for handling the TFT monitors to keep display quality and keep the working area clean.
Do not touch the surface of the monitor as it is easily scratched.
- 2) Wear grounded wrist-straps and use electrostatic neutralization blowers to prevent static charge and discharge when handling the TFT monitors as the LED in this TFT monitors is damageable to electrostatic discharge.
Designate an appropriate operating area, and set equipment, tools, and machines properly when handling this product.
- 3) Avoid strong mechanical shock including knocking, hitting or dropping to the TFT monitors for protecting their glass parts. Do not use the TFT monitors that have been experienced dropping or strong mechanical shock.
- 4) Do not use or storage the TFT monitors at high temperature and high humidity environment. Particularly, never use or storage the TFT monitors at a location where condensation builds up.
- 5) Avoid using and storing TFT monitors at a location where they are exposed to direct sunlight or ultraviolet rays to prevent the LCD panels from deterioration by ultraviolet rays.
- 6) Do not stain or damage the contacts of the connector .
FPC cable needs to be inserted until it can reach to the end of connector slot.
During insertion, make sure to keep the cable in a horizontal position to avoid an oblique insertion.
Otherwise, it may cause poor contact or deteriorate reliability of the connector.
- 7) Peel off the protective film on the TFT monitors during mounting process.
Refer to the section 15.5 on how to peel off the protective film.
We are not responsible for electrostatic discharge failures or other defects occur when peeling off the protective film.
- 8) The volume attached to the monitor is set to the optimal value at the time of shipment from our factory, so please do not change it.

15.3 Precautions for Operation

- 1) Since this TFT monitors are not equipped with light shielding for the driver IC, do not expose the driver IC to strong lights during operation as it may cause functional failures.
- 2) When turning off the power, turn off the input signal before or at the same timing of switching off the power.
- 3) Do not plug in or out the connector while power supply is switch on.
Plug the connector in and out while power supply is switched off.
- 4) Do not operate the TFT monitors in the strong magnetic field. It may break the TFT monitors.
- 5) Do not display a fixed image on the screen for a long time.
Use a screen-saver or other measures to avoid a fixed image displayed on the screen for a long time.
Otherwise, it may cause burn-in image on the screen due the characteristics of liquid crystal.

15.4 Storage Condition for Shipping Cartons

Storage environment

- Temperature 0 to 40°C
- Humidity 60%RH or less
No-condensing occurs under low temperature with high humidity condition.
- Atmosphere No poisonous gas that can erode electronic components and/or wiring materials should be detected.
- Time period 3 months
- Unpacking To prevent damages caused by static electricity, anti-static precautionary measures (e.g. earthing, anti-static mat) should be implemented.
- Maximum piling up 7 cartons

15.5 Precautions for Peeling off the Protective film

The followings work environment and work method are recommended to prevent the TFT monitors from static damage or adhesion of dust when peeling off the protective films.

A) Work Environment

- a) Humidity: 50 to 70 %RH, Temperature 15 to 27°C
- b) Operators should wear conductive shoes, conductive clothes, conductive finger tips and grounded wrist-straps. Anti-static treatment should be implemented to work area's floor.
- c) Use a room shielded against outside dust with sticky floor mat laid at the entrance to eliminate dirt.

B) Work Method

The following procedures should taken to prevent the driver ICs from charging and discharging.

- a) Use an electrostatic neutralization blower to blow air on the TFT monitors to its lower right when FPC is placed at the bottom.
Optimize direction of the blowing air and the distance between the TFT monitors and the electrostatic neutralization blower.
- b) Peel off the tab slowly (spending more than 2 secs to complete) by pulling it to opposite direction.

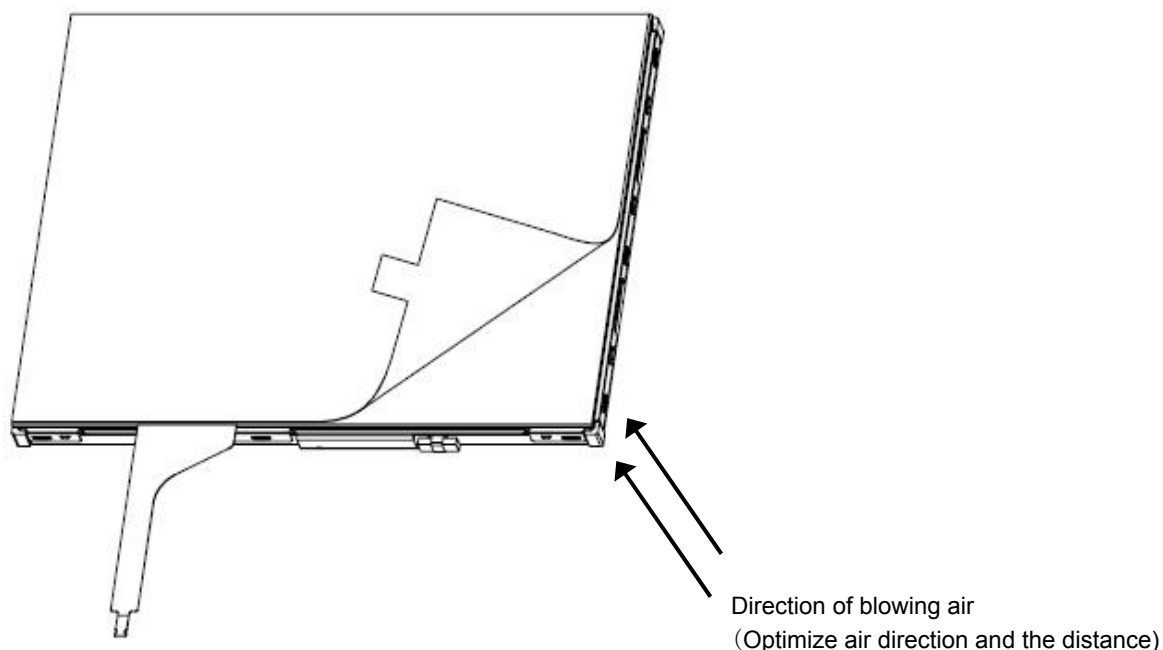

APPENDIX

Reference Method for Measuring Optical Characteristics and Performance

1. Measurement Condition

Measuring instruments: CS1000 (KONICA MINOLTA) , LCD7000(OTSUKA ELECTRONICS) ,EZcontrast160D (ELDIM)

Driving condition: Refer to the section "Optical Characteristics"

Measured temperature: 25°C unless specified

Measurement system: See the chart below. The luminance meter is placed on the normal line of measurement system.

Measurement point: At the center of the screen unless otherwise specified

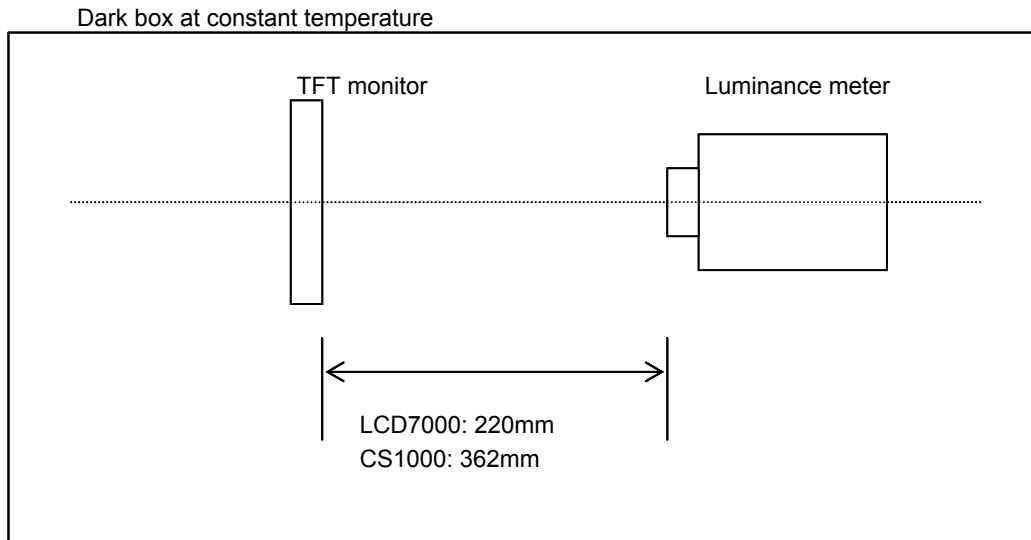

Measurement is made after 30 minutes of lighting of the backlight.

Measurement point: At the center point of the screen
Brightness distribution: 9 points shown in the following drawing.

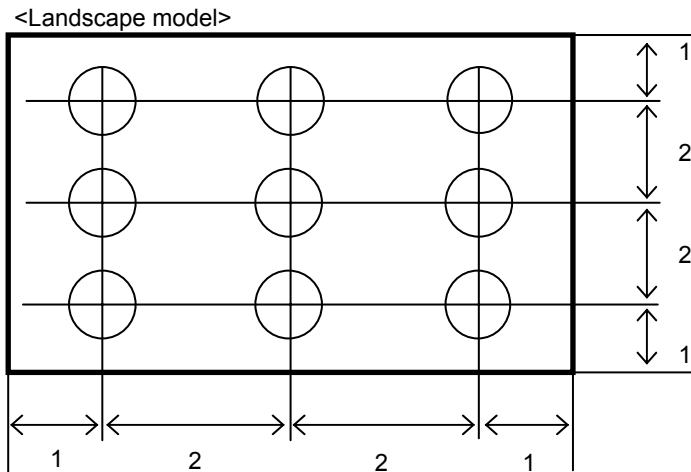

Dimensional ratio of active area

Backlight IL=50mA

2. Test Method

Notice	Item	Test method	Measuring instrument	Remark
1	Response time	<p>Measure output signal waveform by the luminance meter when raster of window pattern is changed from white to black and from black to white.</p>	LCD7000	<p>Black display [Data]=00h White display [Data]=3Fh TON Rise time TOFF Fall time</p>
2	Contrast ratio	<p>Measure maximum luminance Y1([Data]=3Fh) and minimum luminance Y2([Data]=00h) at the center of the screen by displaying raster or window pattern. Then calculate the ratio between these two values.</p> <p>Contrast ratio = Y1/Y2</p> <p>Diameter of measuring point: 8mmφ</p>	CS1000	
3	Viewing angle Horizontalθ Verticalφ	<p>Move the luminance meter from right to left and up and down and determine the angles where contrast ratio is 10.</p>	EZcontrast160D	
4	White chromaticity	<p>Measure chromaticity coordinates x and y of CIE1931 colorimetric system at [Data] = 3Fh</p> <p>Color matching faction: 2°view</p>	CS1000	
5	Burn-in	<p>Visually check burn-in image on the screen after 0.5 hours of "window display" ([Data]=3Fh/00h).</p>		At optimized VCOMDC
6	Center brightness	<p>Measure the brightness at the center of the screen.</p>	CS1000	
7	Brightness distribution	<p>(Brightness distribution) = 100 x B/A %</p> <p>A : max. brightness of the 9 points</p> <p>B : min. brightness of the 9 points</p>	CS1000	

* Linearity Measurement of Touch Panel

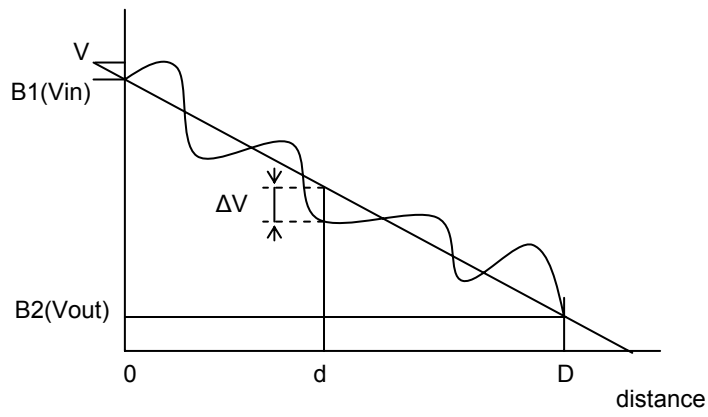

$$LE(\%) = \Delta V / (V_{in} - V_{out}) \times 100$$

$$LE_{max}(\%) = \Delta V_{max} / (V_{in} - V_{out}) \times 100$$

■ Cautionary instruction to handle a Touch-panel

● Cushion (between Touch Panel Chassis) Design

1) A cushion is required to be placed between Touch Panel and customer's chassis and there is a designated area to attach it. Attachment at area inside Input Prohibition Area must be forbidden.

If cushion was located inside Input Prohibition Area, Upper Electrode may be push constantly and which may cause the electrode breakage at the position falling on the edge of adhesive; it eventually results in Touch Panel malfunction in the future. (Please see "NG-1")

2) Be attention to the cushion material you use. In the case that too soft cushion was used, the cushion may protrude into Prohibition Area by being push strongly; which may result in the electrode breakage. Eventually there is a chance that the electrode breakage leads to the malfunction of Touch Panel in the future. (Please see "NG-2")

3) Cushion is required to be attached at the side of Customer's chassis.

Attaching a cushion at the side of Upper Electrode Film has a chance to deform the film and lead to the malfunction of Touch Panel in the future.

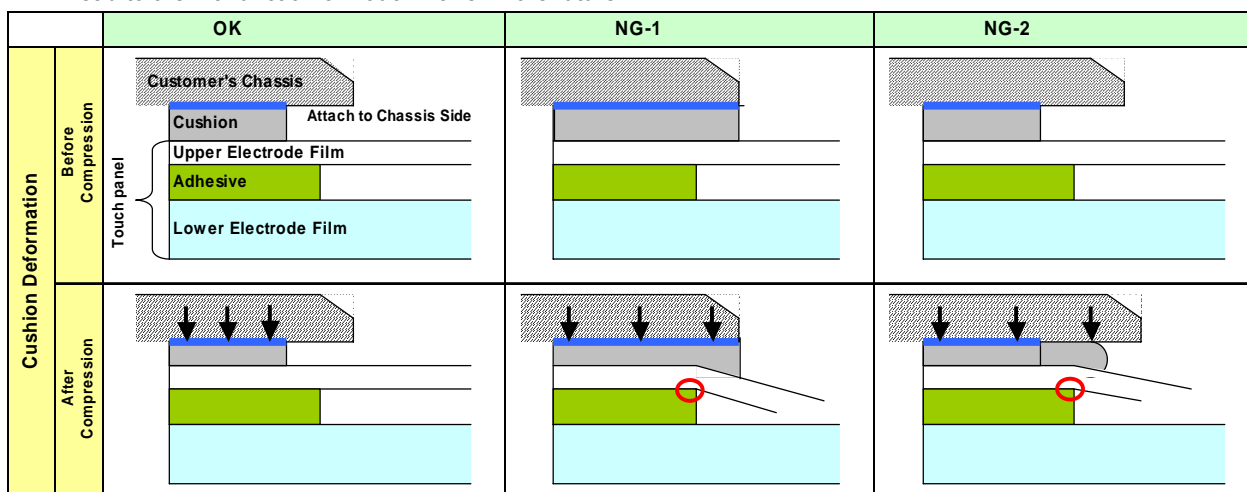

● Design Guidance of Chassis (Front Part)

4) Be attention to stay Input Prohibition Area away from touching and/or drawing by a stylus pens in order to avoid the electrode breakage and potential malfunction of Touch Panel. (Please see "NG-3")

We recommend customers to design chassis (front case) being able to protect Input Prohibition Area.

5) Clearance between customer's chassis and Touch Panel surface is certainly required in order to avoid erroneous input caused by a collision of the edge of chassis. (Please see "NG-4")

A clearance of 0.3 to 0.7mm is recommended.

● Design Guidance of Chassis (Side Part)

6) Upper Electrode and Lower Electrode fall on the edge of Touch Panel outline.

Redundant design having enough clearance to avoid electric short with chassis is highly recommended. (Please see "NG-5")

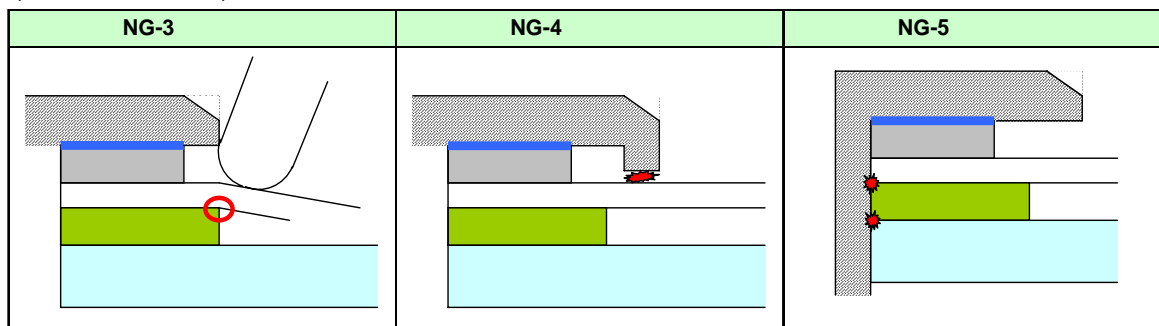

● Example of Recommended Chassis Design

Refer to "3.2 Outward Form".

● As a terminal resistance has individual specificity, calibration to align the displaying and the sensing position one each is mandatory before use.