

Specifications for TFT-LCD Monitor (TENTATIVE)

Version 0.0

MODEL COM70T7M07ZLC

Customer's Approval
Signature:
Name:
Section:
Title:
Date:



ORTUS TECHNOLOGY CO., LTD.
Sales Dept.

Approved by

Checked by

ORTUS TECHNOLOGY CO., LTD.
Product Quality Assurance

Approved by

Checked by

Prepared by

Version History

Ver.	Date	Page	Description
0.0	Nov. 22, 2012	-	- Tentative issue

Contents

1. Application	4
2. Outline Specifications		
2.1 Features of the Product	5
2.2 Display Method	5
3. Dimensions and Shape		
3.1 Dimensions	5
3.2 Outward Form	6
3.3 Serial Label (S-Label)	7
4. Pin Assignment	8
5. Block Diagram	10
6. Absolute Maximum Rating	11
7. Recommended Operating Conditions	11
8. Characteristics		
8.1 DC Characteristics	12
8.2 AC Characteristics	12
8.3 Input Timing Characteristics	14
8.4 Driving Timing Chart	15
8.5 Input Data vs Display color	17
9. Power on/off Sequence	18
10. Characteristics		
10.1 Optical Characteristics	19
10.2 Temperature Characteristics	20
11. Criteria of Judgment		
11.1 Defective Display and Screen Quality	21
11.2 Screen and Other Appearance	22
12. Reliability Test	23
13. Packing Specifications	25
14. Handling Instruction		
14.1 Cautions for Handling LCD panels	26
14.2 Precautions for Handling	27
14.3 Precautions for Operation	27
14.4 Storage Condition for Shipping Cartons	28
14.5 Precautions for Peeling off the Protective film	28
APPENDIX	29

1. Application

This Specification is applicable to 17.8cm (7.0 inch) TFT-LCD monitor for non-military use.

- ⊙ ORTUS TECHNOLOGY makes no warranty or assume no liability that use of this Product and/or any information including drawings in this Specification by Purchaser is not infringing any patent or other intellectual property rights owned by third parties, and ORTUS TECHNOLOGY shall not grant to Purchaser any right to use any patent or other intellectual property rights owned by third parties. Since this Specification contains ORTUS TECHNOLOGY's confidential information and copy right, Purchaser shall use them with high degree of care to prevent any unauthorized use, disclosure, duplication, publication or dissemination of ORTUS TECHNOLOGY'S confidential information and copy right.
- ⊙ If Purchaser intends to use this Products for an application which requires higher level of reliability and/or safety in functionality and/or accuracy such as transport equipment (aircraft, train, automobile, etc.), disaster-prevention/security equipment or various safety equipment, Purchaser shall consult ORTUS TECHNOLOGY on such use in advance.
- ⊙ This Product shall not be used for application which requires extremely higher level of reliability and/or safety such as aerospace equipment, telecommunication equipment for trunk lines, control equipment for nuclear facilities or life-support medical equipment.
- ⊙ ORTUS TECHNOLOGY assumes no liability for any damage resulting from misuse, abuse, and/or miss-operation of the Product deviating from the operating conditions and precautions described in the Specification.
- ⊙ If any issue arises as to information provided in this Specification or any other information, ORTUS TECHNOLOGY and Purchaser shall discuss them in good faith and seek solution.
- ⊙ ORTUS TECHNOLOGY assumes no liability for defects such as electrostatic discharge failure occurred during peeling off the protective film or Purchaser's assembly process.
- ⊙ This Product is compatible for RoHS directive.

Object substance	Maximum content [ppm]
Cadmium and its compound	100
Hexavalent Chromium Compound	1000
Lead & Lead compound	1000
Mercury & Mercury compound	1000
Polybrominated biphenyl series (PBB series)	1000
Polybrominated biphenyl ether series (PBDE series)	1000

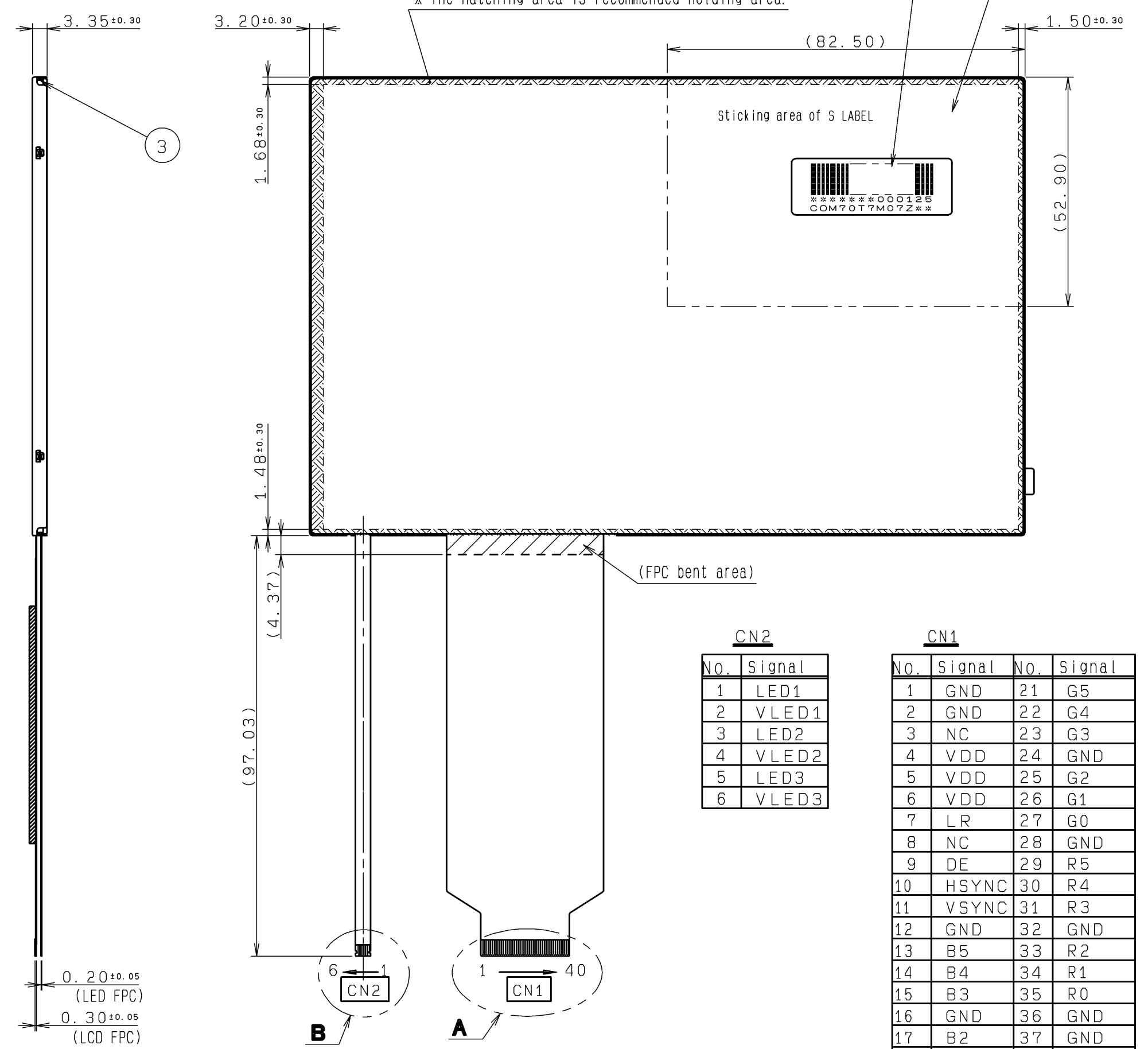
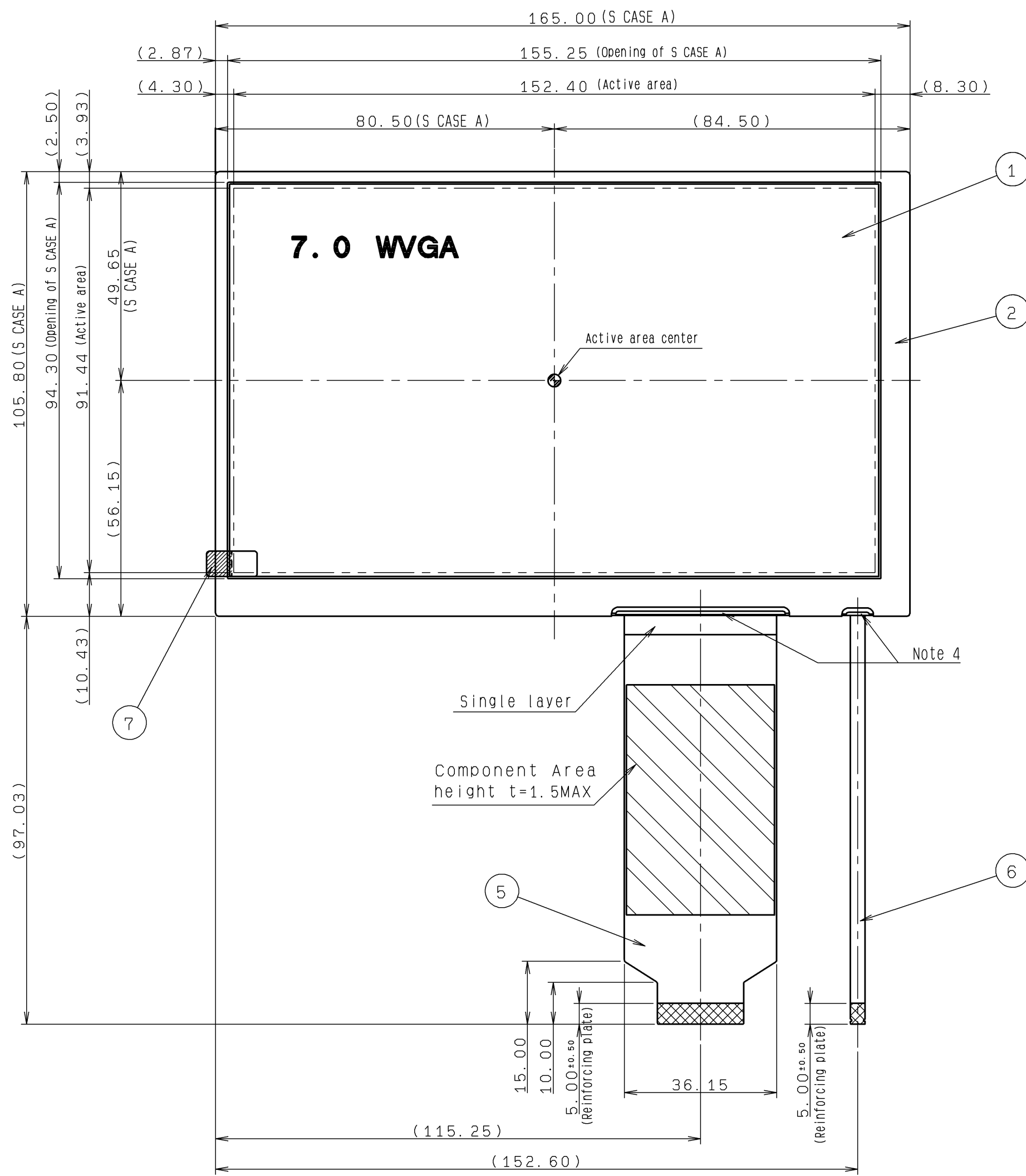

CN2

No.	Signal
1	LED1
2	VLED1
3	LED2
4	VLED2
5	LED3
6	VLED3

CN1

No.	Signal	No.	Signal
1	GND	21	G5
2	GND	22	G4
3	NC	23	G3
4	VDD	24	GND
5	VDD	25	G2
6	VDD	26	G1
7	LR	27	G0
8	NC	28	GND
9	DE	29	R5
10	HSYNC	30	R4
11	VS YNC	31	R3
12	GND	32	GND
13	B5	33	R2
14	B4	34	R1
15	B3	35	R0
16	GND	36	GND
17	B2	37	GND
18	B1	38	DCLK
19	B0	39	UD
20	GND	40	GND

- Note 1. S label is affixed the area shown in the drawing. The thickness of the S label will be added to that of S case's surface.
- Note 2. Protective film is affixed on front surface of the screen. Location tolerance of the protective film shall be ±1.5 mm to the polarizing film.
- Note 3. Recommended FPC connectors
For LCD FPC : HIROSE.
part number: FH12-40S-0.5SH(Lower contact)
- For LED FPC : KYOCERA Connector Products.
part number: 04 6277 006 001 883+(Dual-sided contact)
- Note 4. Exercise care not to apply any forces to the cable holder of the S case A.

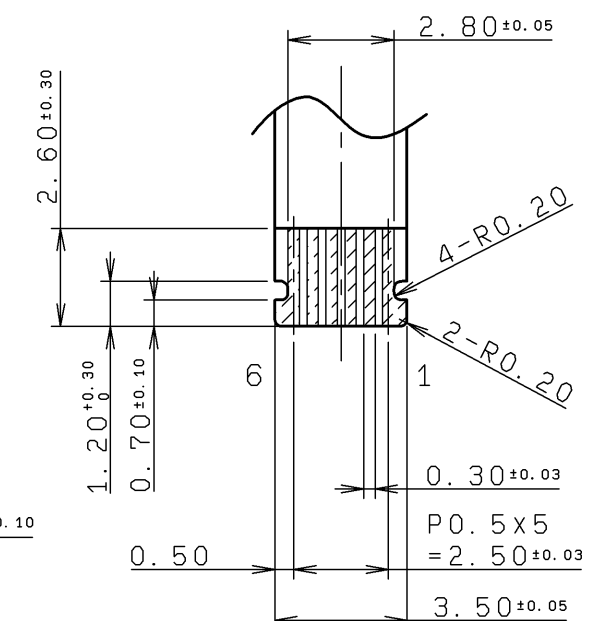
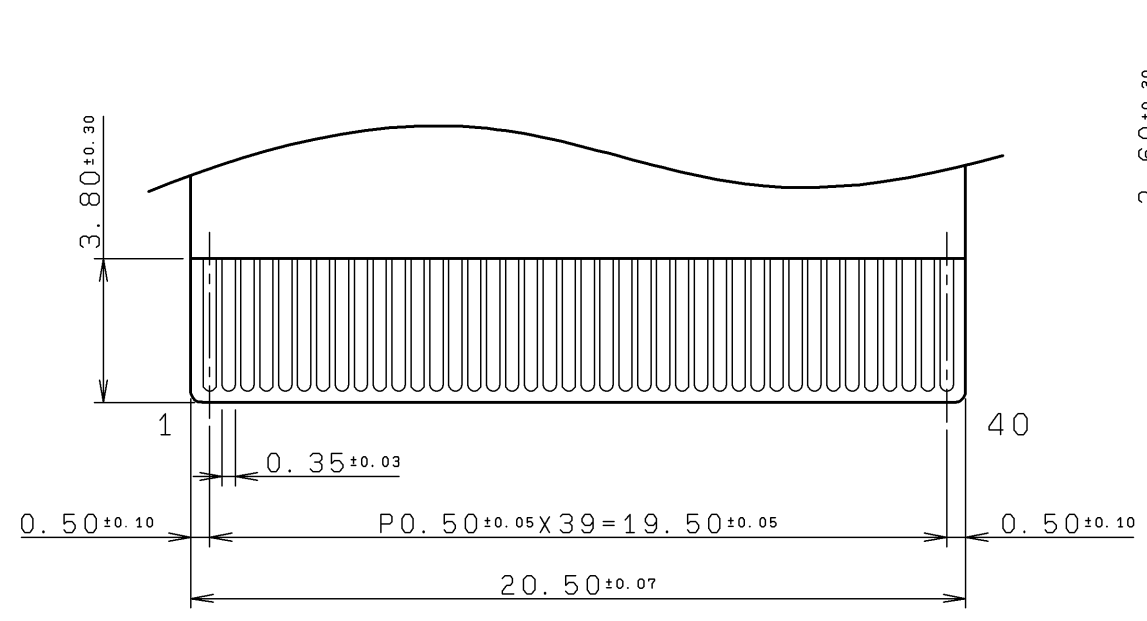

PART NAME	ITEM	MATERIAL GRADE	REMARK
S LABEL	8	Barcode(CODE39)	(37X13X0.075t)
R TAPE	7		
LED FPC	6		
LCD FPC	5		
S CASE C	4		
FRAME	3		
S CASE A	2		
TFT-LCD PANEL	1	Glass substrate thickness=0.5t	

APPROVED Hashizume	GENERAL TOLERANCE ±0.5	SCALE 1/1 (5/1)	UNIT mm
CHECKED Hasegawa	ISSUE (Y:M:D) 12:11:16	MODEL COM70T7M07Z**	
CHECKED	NAME		
DESIGN Ide			
DRAW Ide			

ORTUSTECH	
ORTUS TECHNOLOGY CO., LTD.	
DO NOT DUPLICATE, CONFIDENTIAL AND PROPRIETARY	
DRAWING No.	REV. SHEET DIV.
RJ0524406D201	/

OUTLINE-D7M07

RJ0524406D201

3.3 SERIAL LABEL (S-LABEL)

1) Display Items

A section : Bar code

B section : Combination of a character

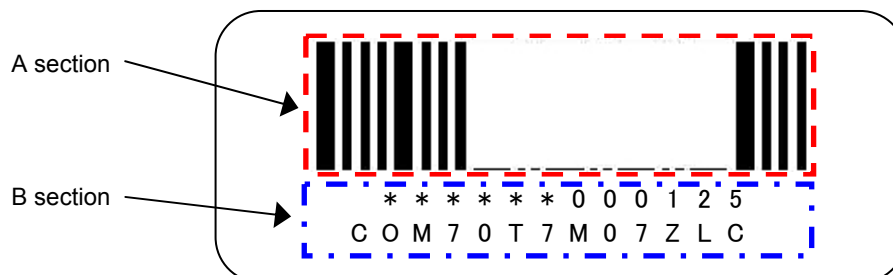

Details of B section

Upper column: It indicates The least significant digit of manufacture year (1 digit), manufacture month with below alphabet (1letter), model code (4characters), serial number (6digits).

*	*	****	*****
-	-	-	-
a	b	c	d

Contents of display													
a	The least significant digit of manufacture year												
b	<table border="1" style="display: inline-table; border-collapse: collapse;"> <tr> <td>Jan-A</td> <td>Mar-C</td> <td>May-E</td> <td>Jul-G</td> <td>Sep-I</td> <td>Nov-K</td> </tr> <tr> <td>Feb-B</td> <td>Apr-D</td> <td>Jun-F</td> <td>Aug-H</td> <td>Oct-J</td> <td>Dec-L</td> </tr> </table>	Jan-A	Mar-C	May-E	Jul-G	Sep-I	Nov-K	Feb-B	Apr-D	Jun-F	Aug-H	Oct-J	Dec-L
Jan-A	Mar-C	May-E	Jul-G	Sep-I	Nov-K								
Feb-B	Apr-D	Jun-F	Aug-H	Oct-J	Dec-L								
c	<table border="1" style="display: inline-table; border-collapse: collapse;"> <tr> <td>70AC</td> <td>(Made in Japan)</td> </tr> <tr> <td>70BC</td> <td>(Made in Malaysia)</td> </tr> </table>	70AC	(Made in Japan)	70BC	(Made in Malaysia)								
70AC	(Made in Japan)												
70BC	(Made in Malaysia)												
d	Serial number												

* Example of indication of Serial label (S-label)

•Made in Japan

3D70AC000125

means "manufactured in April 2013, 7.0" A type,
C specifications, serial number 000125"

•Made in Malaysia

3D70BCC000125

means "manufactured in April 2013, 7.0" B type,
C specifications, serial number 000125"

Lower column: Model (13characters)

2) Location of Serial Label (S-label)

Refer to 3.2 "Outward Form".

2) Others

Bar code readability is excluded from quality assurance coverage.

4. Pin Assignment

4.1 Display Module Part

No.	Symbol	Function
1	GND	GND.
2	GND	GND.
3	NC	No connection
4	VDD	Power supply input.
5	VDD	Power supply input.
6	VDD	Power supply input.
7	LR	Horizontally Flipped (right/left) Signal. (Lo: Horizontally Flipped Display, Hi: Normal display)
8	NC	No connection
9	DE	Input data effective signal. (positive polarity) Input GND level when "SYNC mode".
10	HSYNC	Horizontal sync signal input.(negative polarity) Input GND level when "DE mode".
11	VSYNC	Vertical sync signal input.(negative polarity) Input GND level when "DE mode".
12	GND	GND.
13	B5	Display data input for Blue 5(MSB).
14	B4	Display data input for Blue 4.
15	B3	Display data input for Blue 3.
16	GND	GND.
17	B2	Display data input for Blue 2.
18	B1	Display data input for Blue 1.
19	B0	Display data input for Blue 0(LSB).
20	GND	GND.
21	G5	Display data input for Green 5(MSB).
22	G4	Display data input for Green 4.
23	G3	Display data input for Green 3.
24	GND	GND.
25	G2	Display data input for Green 2.
26	G1	Display data input for Green 1.
27	G0	Display data input for Green 0(LSB).
28	GND	GND.
29	R5	Display data input for Red 5(MSB).
30	R4	Display data input for Red 4.
31	R3	Display data input for Red 3.
32	GND	GND.
33	R2	Display data input for Red 2.
34	R1	Display data input for Red 1.
35	R0	Display data input for Red 0(LSB).
36	GND	GND.
37	GND	GND.
38	DCLK	Clock signal.Latching data at the falling edge.
39	UD	Vertically Flipped (up/down) Signal. (Lo: Normal display,Hi: Vertically Flipped Display)
40	GND	GND.

- Recommended connector : HIROSE FH 12 series [FH12-40S-0.5SH]
- Please refer to the section "3.2 Outward Form" for pin terminal order.

4.2 Backlight Part

No.	Symbol	Function
1	LED 1	LED 1 cathode side.
2	VLED 1	LED 1 anode side.
3	LED 2	LED 2 cathode side.
4	VLED 2	LED 2 anode side.
5	LED 3	LED 3 cathode side.
6	VLED 3	LED 3 anode side.

- Recommended connector: KYOSERA 6277 series [04 6277 006 001 883+]
- Please refer to the section "3.2 Outward Form" for pin terminal order.

5. Block Diagram

Each arrow shows signal flow.

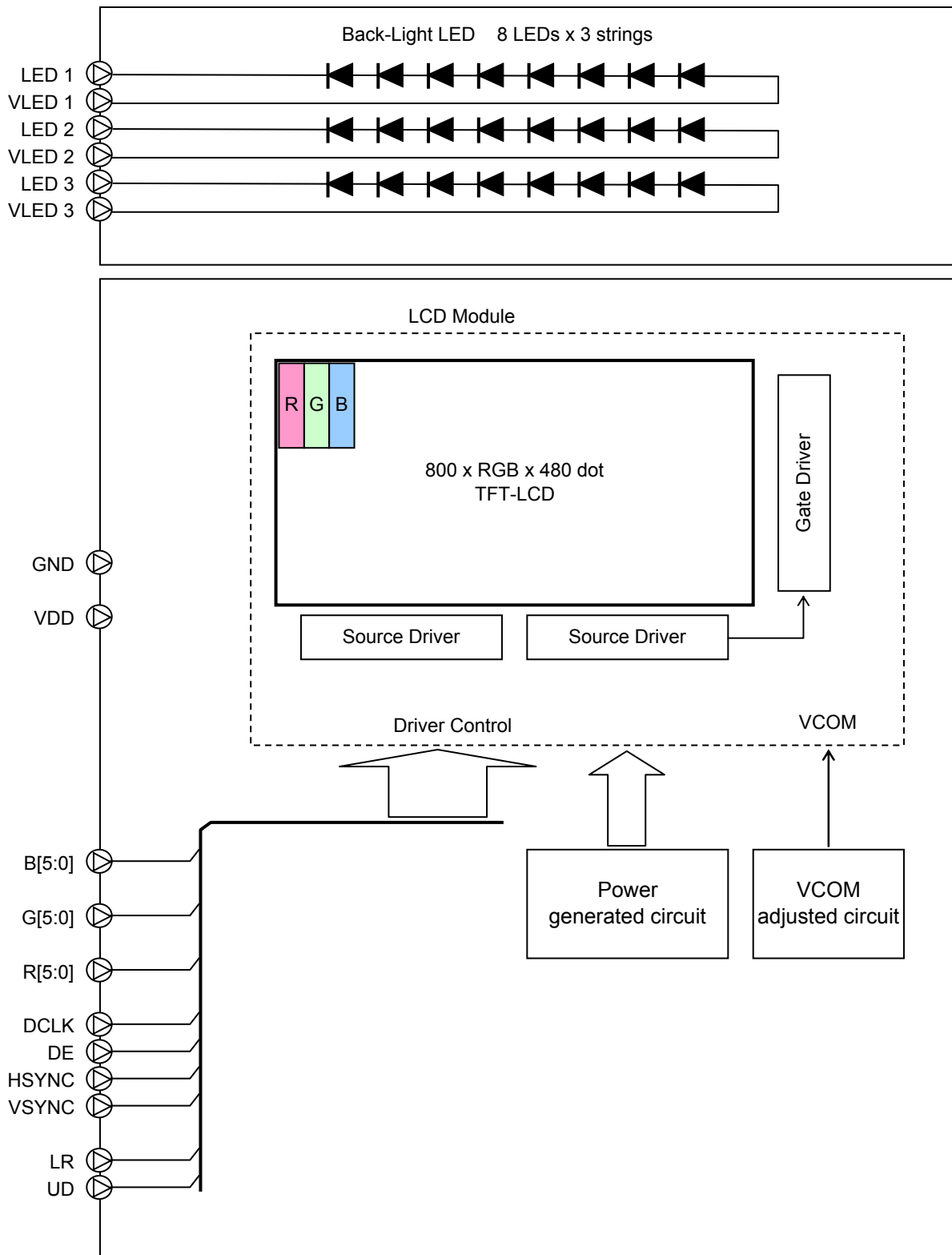

6. Absolute Maximum Rating

GND=0V

Item	Symbol	Rating		Unit	Applicable terminal
		MIN	MAX		
Supply voltage	VDD	-0.3	6.0	V	VDD
Input voltage for logic	VI	-0.3	VDD+0.3	V	B[5:0],G[5:0],R[5:0],DCLK, DE,HSYNC,VSYNC,LR,UD
LED forward current	IL	--	30 (note)	mA	VLED1-LED1,VLED2-LED2 VLED3-LED3
Storage temperature range	Tstg	-30	80	°C	

Absolute maximum ratings is parametric values , should never be exceed any value at any moment .

Beyond which, it could be suffered from changes in characteristics and never be restored .

Moreover, it could even be suffered from permanent destruction.

Therefore, please note enough the fluctuation of input voltage, the characteristics of connected parts,

I/O signal line surge, and ambient temperature, on designing the circuit.

(note) Please refer to the figure below allowable current characteristic - Ta of the LED.

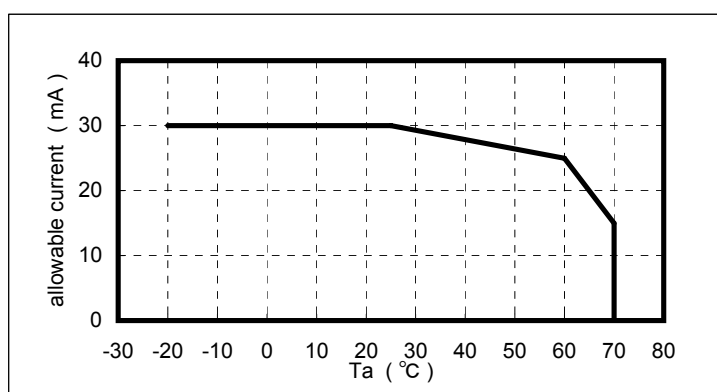

7. Recommended Operating Conditions

GND=0V

Item	Symbol	Condition	Rating			Unit	Applicable terminal
			MIN	TYP	MAX		
Supply voltage	VDD		3.0	3.3	3.6	V	VDD
Input voltage for logic	VI	VDD=3.0~3.6V	0	--	VDD	V	B[5:0],G[5:0], R[5:0],DCLK, DE,HSYNC, VSYNC,LR,UD
Operating temperature range	Top	Note1,2	-20	25	70	°C	Panel surface temperature
Operating humidity range	Hop	Ta ≤ 40°C	20	--	85	%	
		Ta > 40°C	Non condensing in an environmental moisture at or less than 40°C 85%RH.				

Note1: The temperature within the display will increase due to the heat radiated from the back light while in operation.

Necessary measures have to be taken in the product design to make sure that the display has proper ventilation so that temperature on any surface of this display should not exceed 70 °C.

Note2: This monitor is operable in this temperature range. With regard to optical characteristics, refer to Item "10. CHARACTERISTICS".

8. Characteristics

8.1 DC Characteristics

8.1.1 Display Module

(Unless otherwise noted, $T_a=25^{\circ}\text{C}$, $V_{DD}=3.3\text{V}$, $GND=0\text{V}$)

Item	Symbol	Condition	Rating			Unit	Applicable terminal
			MIN	TYP	MAX		
Input voltage for logic	V_{IH}		$0.8 \times V_{DD}$	--	V_{DD}	V	B[5:0], G[5:0], R[5:0], DCLK, DE, HSYNC, VSYNC, LR, UD
	V_{IL}		0	--	$0.2 \times V_{DD}$	V	
Current consumption	I_{DD}	$F_{cph}=33.26\text{MHz}/T_v=60\text{Hz}$ Color bar display	--	(170)	(340)	mA	VDD

8.1.2 Backlight

Item	Symbol	Condition	Rating			Unit	Applicable terminal
			MIN	TYP	MAX		
Forward current	IL	$T_a=25^{\circ}\text{C}$	--	20	30	mA	VLED1-LED1, VLED2-LED2, VLED3-LED3
Forward voltage	VL	$T_a=25^{\circ}\text{C}$, $I_L=20\text{mA}$	--	24.8	27.2	V	

8.2 AC Characteristics

($T_a=25^{\circ}\text{C}$, $V_{DD}=3.3\text{V}$, $GND=0\text{V}$)

Item	Symbol	Rating			Unit
		MIN	TYP	MAX	
CLK pulse duty	T_{cwh}	40	50	60	%
HS setup time	T_{hst}	6	--	--	ns
HS hold time	T_{hhd}	6	--	--	ns
VS setup time	T_{vst}	6	--	--	ns
VS hold time	T_{vhd}	6	--	--	ns
Data setup time	T_{dsu}	6	--	--	ns
Data hold time	T_{dhd}	6	--	--	ns
DE setup time	T_{esu}	6	--	--	ns

Switching Waveform Characteristics

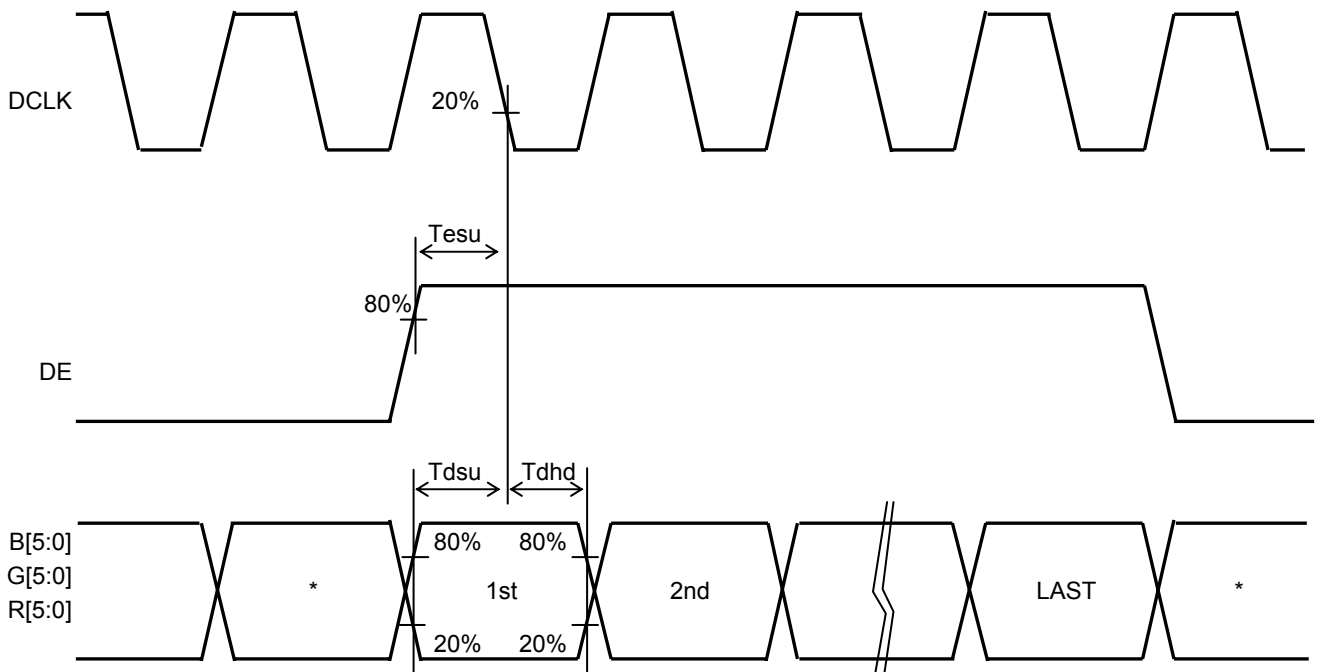
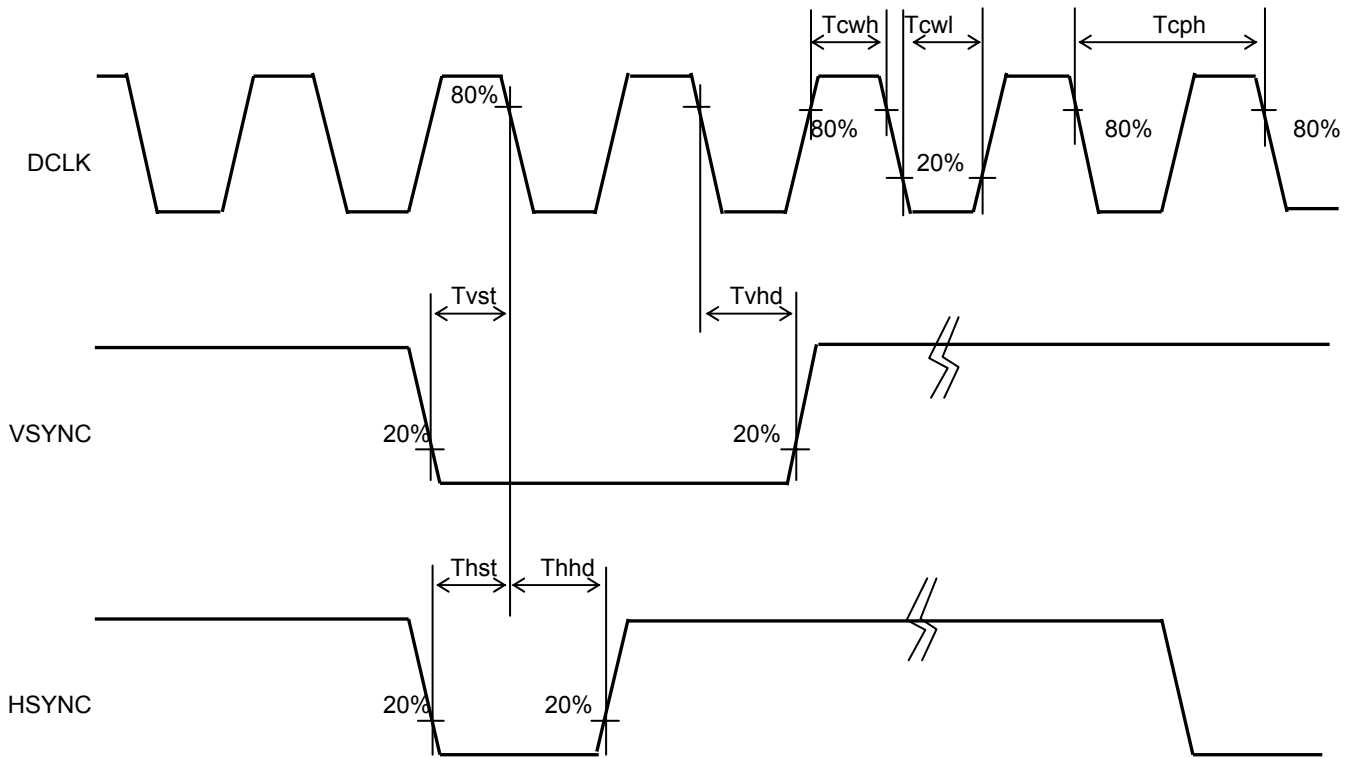

*: INVALID

8.3 Input Timing Characteristics

< Sync mode >

Ta=25°C, VDD=3.3V, GND=0V

Item	Symbol	Rating			Unit
		MIN	TYP	MAX	
CLK frequency	F_{CPH}	29.40	33.26	42.48	MHz
CLK period	T_{CPH}	23.54	30.06	34.01	ns
HS period	T_H	1018	1056	-	T_{CPH}
HS pulse width	T_{WH}	1	128	-	T_{CPH}
HS-first horizontal data time	T_{HS}	216			T_{CPH}
HS Active Time	T_{HA}	800			T_{CPH}
VS period	T_V	517	525	-	T_H
VS pulse width	T_{WV}	1	2	-	T_H
VS-DE time	T_{VS}	35			T_H
VS Active Time	T_{VA}	480			T_H

< DE mode >

Ta=25°C, VDD=3.3V, GND=0V

Item	Symbol	Rating			Unit
		MIN	TYP	MAX	
CLK frequency	F_{CPH}	29.40	33.26	42.48	MHz
CLK period	T_{CPH}	23.54	30.06	34.01	ns
DE period	T_H	1000	1056	1200	T_{CPH}
DE pulse width	T_{DEH}	800			T_{CPH}
DE frame blanking	T_{DEB}	10	45	110	T_H
DE frame width	T_{DEVA}	480			T_H

8.4 Driving Timing Chart

< SYNC mode >

-Vertical Timing

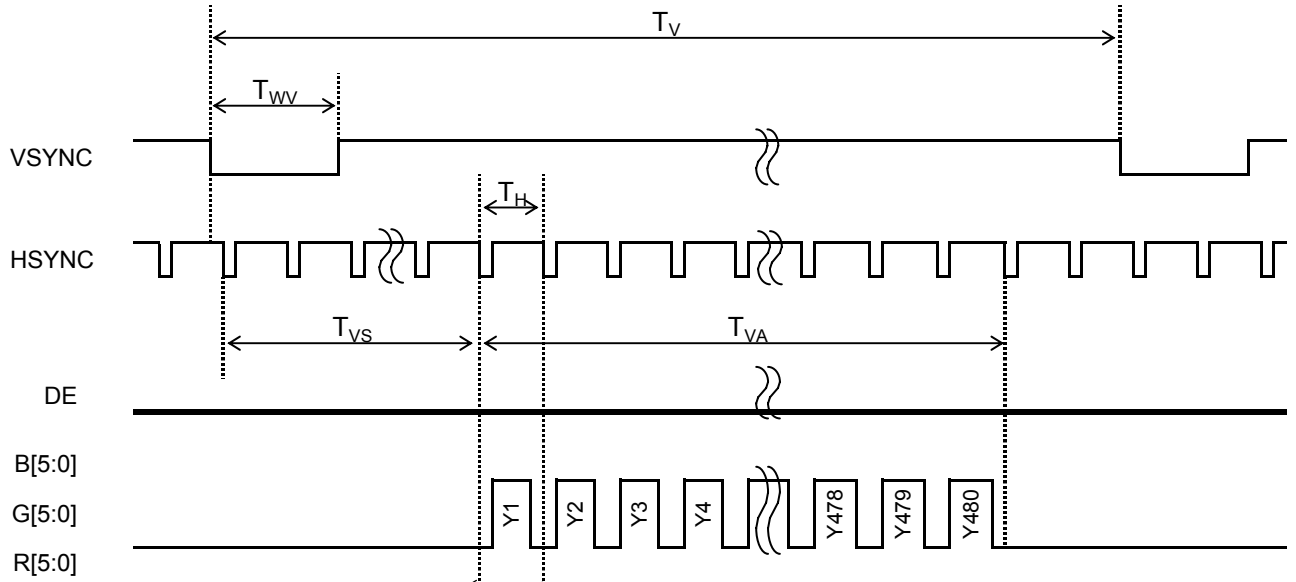

-Horizontal Timing

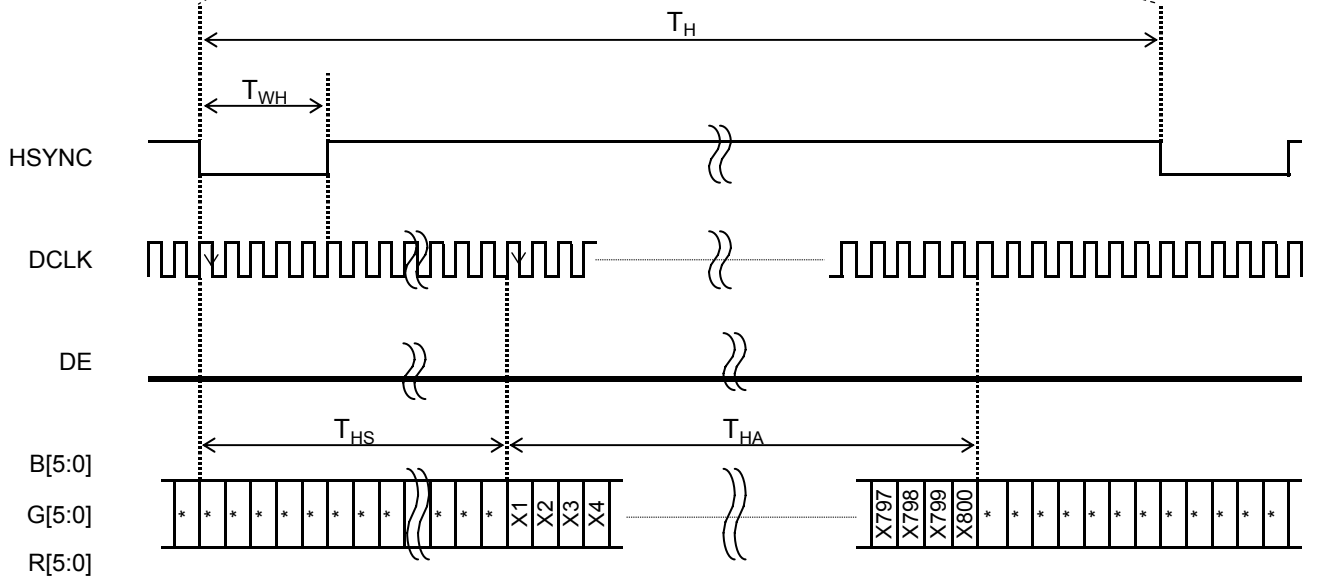

< DE mode >

-Vertical Timing

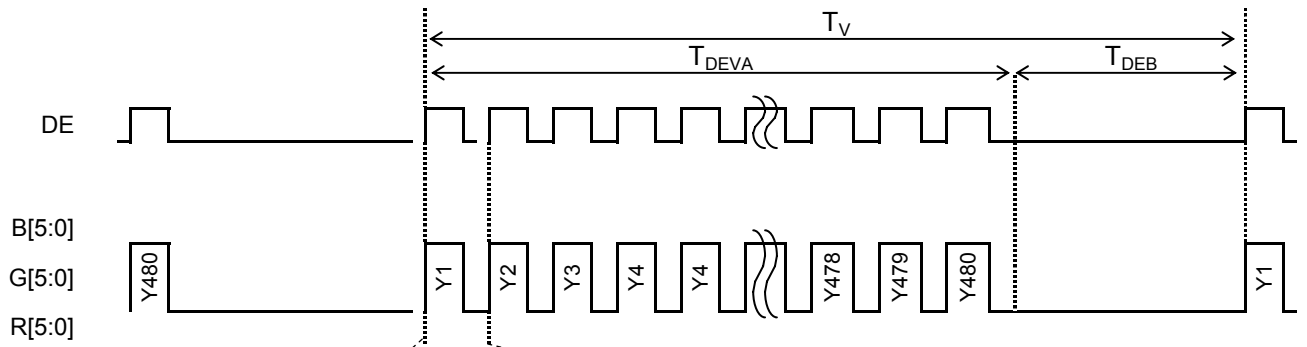

-Horizontal Timing

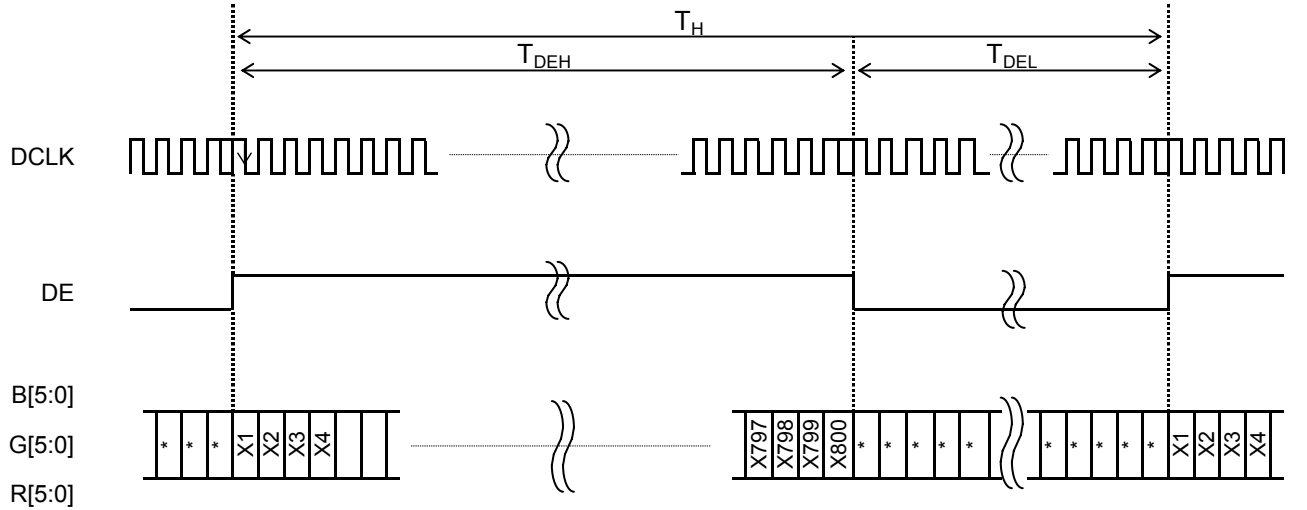

8.5. Input Data vs Display color

DISPLAY		INPUT DATA SIGNAL																	
		R5	R4	R3	R2	R1	R0	G5	G4	G3	G2	G1	G0	B5	B4	B3	B2	B1	B0
BASIC COLOR	BLACK	0	0	0	0	0	0	0	0	0	0	0	0	0	0	0	0	0	0
	BLUE	0	0	0	0	0	0	0	0	0	0	0	0	1	1	1	1	1	1
	GREEN	0	0	0	0	0	0	1	1	1	1	1	1	0	0	0	0	0	0
	CYAN	0	0	0	0	0	0	1	1	1	1	1	1	1	1	1	1	1	1
	RED	1	1	1	1	1	1	0	0	0	0	0	0	0	0	0	0	0	0
	MAGENTA	1	1	1	1	1	1	0	0	0	0	0	0	1	1	1	1	1	1
	YELLOW	1	1	1	1	1	1	1	1	1	1	1	1	0	0	0	0	0	0
	WHITE	1	1	1	1	1	1	1	1	1	1	1	1	1	1	1	1	1	1
GRAY SCALE OF RED	BLACK	0	0	0	0	0	0	0	0	0	0	0	0	0	0	0	0	0	0
	↑	0	0	0	0	0	1	0	0	0	0	0	0	0	0	0	0	0	0
	dark	0	0	0	0	1	0	0	0	0	0	0	0	0	0	0	0	0	0
	↑																		
	↓																		
	light	1	1	1	1	0	1	0	0	0	0	0	0	0	0	0	0	0	0
	↓	1	1	1	1	1	0	0	0	0	0	0	0	0	0	0	0	0	0
	RED	1	1	1	1	1	1	0	0	0	0	0	0	0	0	0	0	0	0
GRAY SCALE OF GREEN	BLACK	0	0	0	0	0	0	0	0	0	0	0	0	0	0	0	0	0	0
	↑	0	0	0	0	0	0	0	0	0	0	1	0	0	0	0	0	0	0
	dark	0	0	0	0	0	0	0	0	0	1	0	0	0	0	0	0	0	0
	↑																		
	↓																		
	light	0	0	0	0	0	0	1	1	1	1	0	1	0	0	0	0	0	0
	↓	0	0	0	0	0	0	1	1	1	1	1	0	0	0	0	0	0	0
	GREEN	0	0	0	0	0	0	1	1	1	1	1	1	0	0	0	0	0	0
GRAY SCALE OF BLUE	BLACK	0	0	0	0	0	0	0	0	0	0	0	0	0	0	0	0	0	0
	↑	0	0	0	0	0	0	0	0	0	0	0	0	0	0	0	0	0	1
	dark	0	0	0	0	0	0	0	0	0	0	0	0	0	0	0	0	1	0
	↑																		
	↓																		
	light	0	0	0	0	0	0	0	0	0	0	0	0	1	1	1	1	0	1
	↓	0	0	0	0	0	0	0	0	0	0	0	0	1	1	1	1	1	0
	BLUE	0	0	0	0	0	0	0	0	0	0	0	0	1	1	1	1	1	1
GRAY SCALE OF WHITE	BLACK	0	0	0	0	0	0	0	0	0	0	0	0	0	0	0	0	0	0
	↑	0	0	0	0	0	1	0	0	0	0	0	1	0	0	0	0	0	1
	dark	0	0	0	0	1	0	0	0	0	1	0	0	0	0	0	1	0	0
	↑																		
	↓																		
	light	1	1	1	1	0	1	1	1	1	0	1	1	1	1	1	0	1	1
	↓	1	1	1	1	1	0	1	1	1	1	0	1	1	1	1	1	1	0
	WHITE	1	1	1	1	1	1	1	1	1	1	1	1	1	1	1	1	1	1

9. Power on/off Sequence

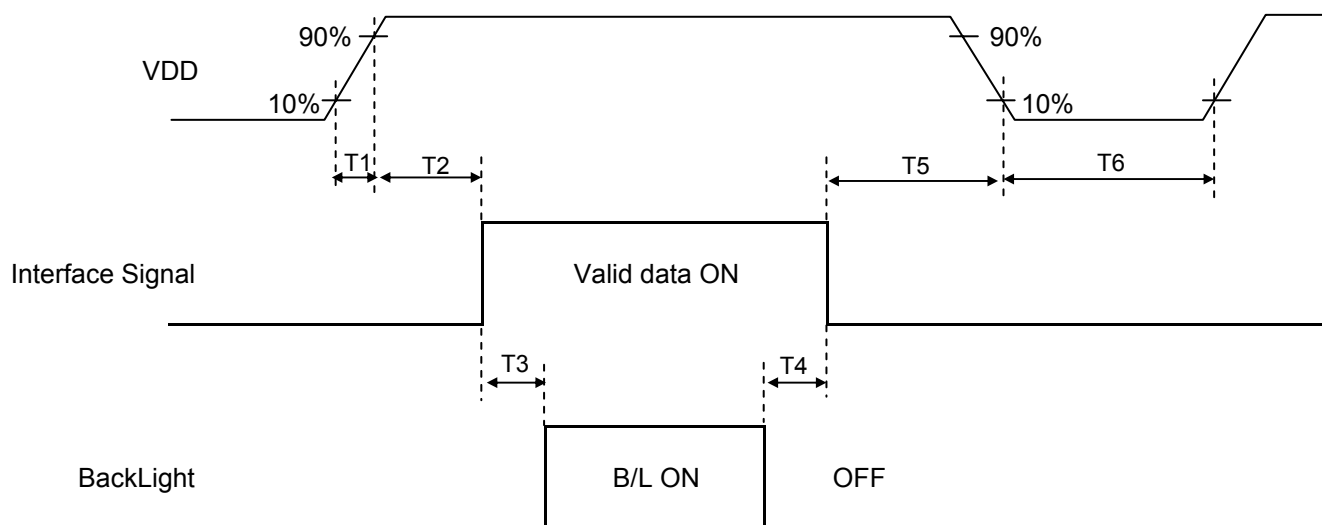

Item	Rating			Unit
	Min	TYP	MAX	
T1	0.1	--	2	ms
T2	0	60	100	ms
T3	200	--	--	ms
T4	200	--	--	ms
T5	1	--	100	ms
T6	1000	--	--	ms

10. Characteristics

10.1 Optical Characteristics

< Measurement Condition >

Measuring instruments: CS1000 (KONICA MINOLTA), LCD7000(OTSUKA ELECTRONICS),
EZcontrast160D (ELDIM)

Driving condition: VDD = 3.3V, GND = 0V
Optimized VCOMDC

Backlight: IL=20.0mA

Measured temperature: Ta=25° C

Item	Symbol	Condition	MIN	TYP	MAX	Unit	Note No.	Remark
Response time	Rise time	TON	[Data]= (3F)h → (00)h	—	—	(40)	ms	1 ※
	Fall time	TOFF	[Data]= (00)h → (3F)h	—	—	(60)	ms	
Contrast ratio	CR	[Data]= (3F)h / (00)h	(250)	(400)	—		2	
Viewing angle	Left	θL	[Data]= (3F)h / (00)h CR ≥ (10)	—	(55)	—	deg	3 ※
	Right	θR		—	(65)	—	deg	
	Up	φU		—	(70)	—	deg	
	Down	φD		—	(70)	—	deg	
White Chromaticity	x	[Data]=(3F)h	White chromaticity range				4	
	y							
Burn-in			No noticeable burn-in image should be observed after 2 hours of window pattern display.				5	
Center brightness		[Data]=(3F)h	(320)	(450)	—	cd/m ²	6	
Brightness distribution		[Data]=(3F)h	(70)	—	—	%	7	

* Note number 1 to 7: Refer to the APPENDIX of "Reference Method for Measuring Optical Characteristics".

※ Measured in the form of LCD module.

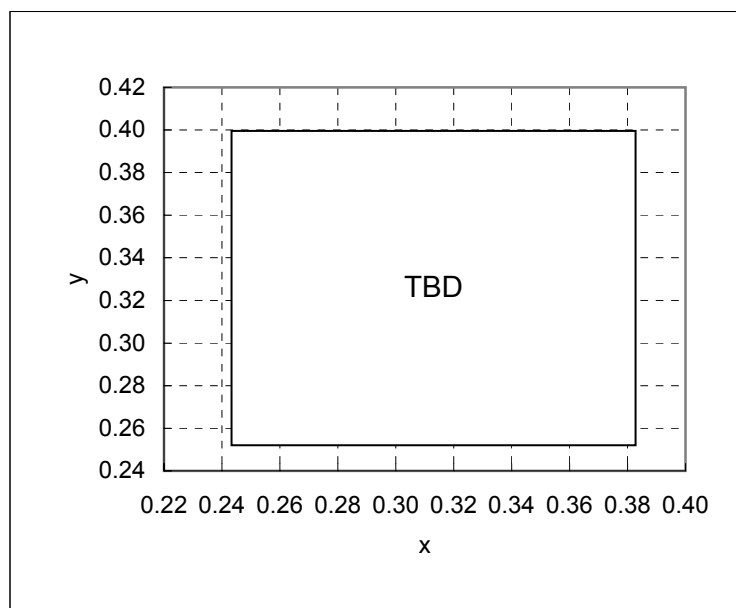

White Chromaticity Range

【White Chromaticity Range】

x	y
TBD	TBD
TBD	TBD
TBD	TBD
TBD	TBD
TBD	TBD
TBD	TBD
TBD	TBD
TBD	TBD

10.2 Temperature Characteristics

< Measurement Condition >

Measuring instruments: CS1000 (KONICA MINOLTA), LCD7000 (OTSUKA ELECTRONICS)

Driving condition: VDD = 3.3V, GND = 0V

Optimized VCOMDC

Backlight: IL=20.0mA

Item		Specification		Remark	
		Ta = -10° C	Ta = 70° C		
Contrast ratio	CR	(40) or more	(40) or more		
Response time	Rise time	TON	(200) msec or less	(30) msec or less	※
	Fall time	TOFF	(300) msec or less	(50) msec or less	※
Display Quality		No noticeable display defect or ununiformity should be observed.		Use the criteria for judgment specified in the section 11.	

※ Measured in the form of LCD module.

11. Criteria of Judgment

11.1 Defective Display and Screen Quality

Test Condition: Observed TFT-LCD monitor from front during operation with the following conditions
 Driving Signal Raster Patter (RGB in monochrome, white, black)
 Signal condition [Data]= (00)h, (20)h, (3F)h (3steps)
 Observation distance 30 cm
 Illuminance 200 to 350 lx
 Backlight IL=20.0mA

Defect item		Defect content	Criteria	
Display Quality	Line defect	Black, white or color line, 3 or more neighboring defective dots	Not exists	
	Dot defect	Uneven brightness on dot-by-dot base due to defective TFT or CF, or dust is counted as dot defect (brighter dot, darker dot) High bright dot: Visible through 2% ND filter at [Data]=(00)h Low bright dot: Visible through 5% ND filter at [Data]=(00)h Dark dot: Appear dark through white display at [Data]=(20)h	Refer to table 1	
Screen Quality	Dirt	Uneven brightness (white stain, black stain etc)	Invisible through 1% ND filter	
	Foreign particle	Point-like	$\varphi \leq 0.20\text{mm}$	Ignored
			$0.20\text{mm} < \varphi \leq 0.25\text{mm}$	$N \leq 3$
			$0.25\text{mm} < \varphi \leq 0.40\text{mm}$	$N \leq 2$
			$0.40\text{mm} < \varphi \leq 0.50\text{mm}$	$N \leq 1$
			$0.50\text{mm} < \varphi$	$N=0$
	Liner	$L \leq 6.0\text{mm}$ and $W \leq 0.10\text{mm}$	$N \leq 2$	
$6.0\text{mm} < L$ or $0.10\text{mm} < W$		$N=0$		
Others		Use boundary sample for judgment when necessary		

φ (mm): Average diameter = (major axis + minor axis)/2
 L (mm): Length
 W (mm): Width
 N: Permissible number

Table 1

Area	High bright dot	Low bright dot	Dark dot	Total	Criteria
A	0	2	2	3	Permissible distance between same color bright dots (includes neighboring dots): 3 mm or more Permissible distance between same color high bright dots (includes neighboring dots): 5 mm or more
B	2	4	4	6	
Total	2	4	4	7	

<Landscape model>

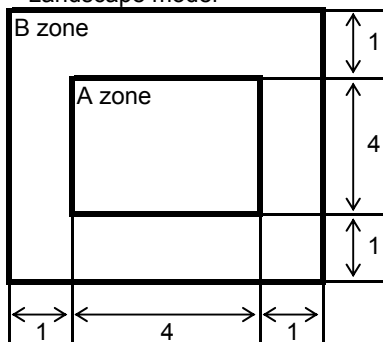

Division of A and B areas
 B area: Active area
 Dimensional ratio between A and B areas: 1: 4: 1 (Refer to the left figure)

11.2 Screen and Other Appearance

Testing conditions

Observation distance

30cm

Illuminance

1200~2000 lx

Item		Criteria	Remark
Polarizer	Flaw	Ignore invisible defect when the backlight is on.	Applicable area: Active area only (Refer to the section 3.2 "Outward form")
	Stain		
	Bubble		
	Dust		
	Dent		
S-case		No functional defect occurs	
FPC cable		No functional defect occurs	

12. Reliability Test

Test item		Test condition		number of failures /number of examinations
Durability test	High temperature storage	Ta=80° C	240H	TBD
	Low temperature storage	Ta=(-30° C)	240H	TBD
	High temperature & high humidity storage	Ta=60° C, RH=90% non condensing	240H	TBD
	High temperature operation	Tp=70° C	240H	TBD
	Low temperature operation	Tp=(-20° C)	240H	TBD
	High temp & humid operation	Tp=40° C, RH=90% non condensing	240H	TBD
	Thermal shock storage	(-30)←→80° C(30min/30min)	100 cycles	TBD
Mechanical environmental test	Surface discharge test (Non operation)	C=250pF, R=100Ω, V=±(8)kV Each 5 times of discharge in both polarities on the center of screen with the case grounded.		TBD
	Vibration test	Total amplitude 1.5mm, f=10~55Hz, X,Y,Z directions for each 2 hours		TBD
	Impact test	Use ORTUS TECHNOLOGY original jig (see next page)and make an impact with peak acceleration of 1000m/s ² for 6 msec with half sine-curve at 3 times to each X, Y, Z directions in conformance with JIS C 60068-2-27-2011.		TBD
Packing test	Packing vibration-proof test	Acceleration of 19.6m/s ² with frequency of 10→55→10Hz, X,Y, Zdirection for each 30 minutes		TBD
	Packing drop test	Drop from 75cm high. 1 time to each 6 surfaces, 3 edges, 1 corner		TBD

Note: Ta=ambient temperature Tp=Panel temperature

※ The profile of high temperature/humidity storage and High Temperature/humidity operation (Pure water of over 10MΩ·cm shall be used.)

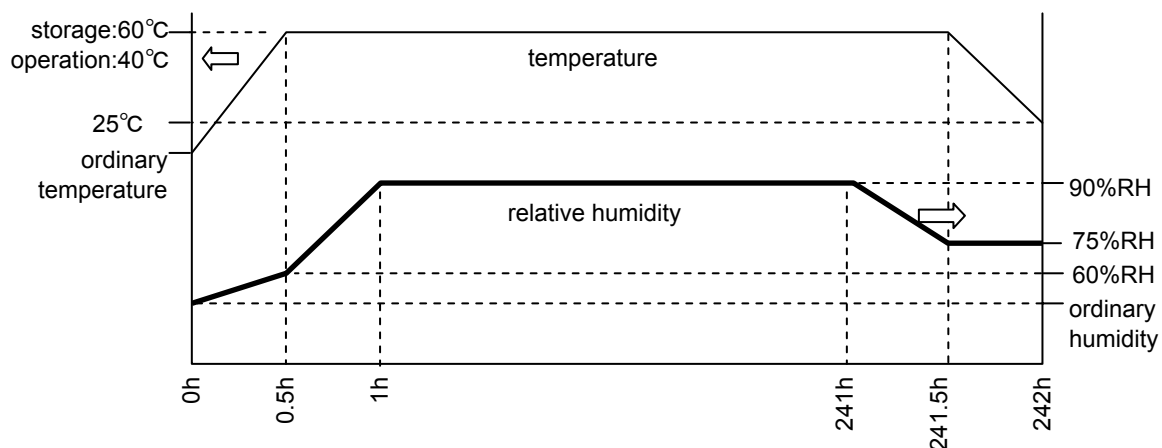
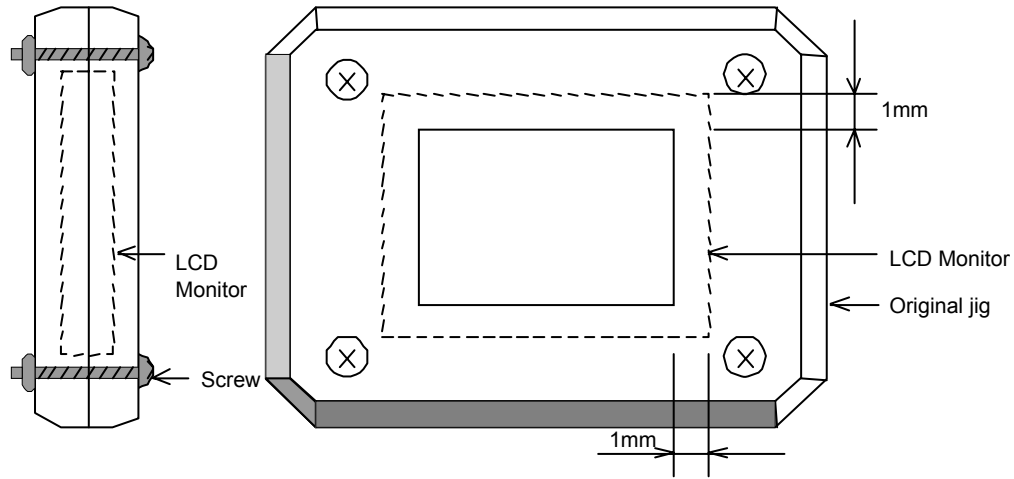

Table2.Reliability Criteria

The parameters should be measured after leaving the monitor at the ordinary temperature for 24 hours or more after the test completion.

item	Standard	Remarks
Display quality	No visible abnormality shall be seen.	
Contrast ratio	40 or more	

ORTUS TECHNOLOGY Original Jig



13. Packing Specifications

TBD

14. Handling Instruction

14.1 Cautions for Handling LCD panels

**Caution**

- (1) Do not make an impact on the LCD panel glass because it may break and you may get injured from it.
- (2) If the glass breaks, do not touch it with bare hands.
(Fragment of broken glass may stick you or you cut yourself on it.)
- (3) If you get injured, receive adequate first aid and consult a medial doctor.
- (4) Do not let liquid crystal get into your mouth.
(If the LCD panel glass breaks, try not let liquid crystal get into your mouth even toxic property of liquid crystal has not been confirmed.)
- (5) If liquid crystal adheres, rinse it out thoroughly.
(If liquid crystal adheres to your cloth or skin, wipe it off with rubbing alcohol or wash it thoroughly with soap. If liquid crystal gets into eyes, rinse it with clean water for at least 15 minutes and consult an eye doctor.)
- (6) If you scrap this products, follow a disposal standard of industrial waste that is legally valid in the community, country or territory where you reside.
- (7) Do not connect or disconnect this product while its application products is powered on.
- (8) Do not attempt to disassemble or modify this product as it is precision component.
- (9) If a part of soldering part has been exposed, and avoid contact (short-circuit) with a metallic part of the case etc. about FPC of this model, please.
Please insulate it with the insulating tape etc. if necessary.
The defective operation is caused, and there is a possibility to generation of heat and the ignition.
- (10) Since excess current protection circuit is not built in this TFT module, there is the possibility that LCD module or peripheral circuit become feverish and burned in case abnormal operation is generated.
We recommend you to add excess current protection circuit to power supply.
- (11) The devices on the FPC are damageable to electrostatic discharge, because the terminals of the devices are exposed.
Wear grounded wrist-straps and use electrostatic neutralization blowers to prevent static charge and discharge when handling the TFT monitors.
Designate an appropriate operating area, and set equipment, tools, and machines properly when handling this product.

**Caution**

This mark is used to indicate a precaution or an instruction which, if not correctly observed, may result in bodily injury, or material damages alone.

14.2 Precautions for Handling

- 1) Wear finger tips at incoming inspection and for handling the TFT monitors to keep display quality and keep the working area clean.
Do not touch the surface of the monitor as it is easily scratched.
- 2) Wear grounded wrist-straps and use electrostatic neutralization blowers to prevent static charge and discharge when handling the TFT monitors as the LED in this TFT monitors is damageable to electrostatic discharge.
Designate an appropriate operating area, and set equipment, tools, and machines properly when handling this product.
- 3) Avoid strong mechanical shock including knocking, hitting or dropping to the TFT monitors for protecting their glass parts. Do not use the TFT monitors that have been experienced dropping or strong mechanical shock.
- 4) Do not use or storage the TFT monitors at high temperature and high humidity environment. Particularly, never use or storage the TFT monitors at a location where condensation builds up.
- 5) Avoid using and storing TFT monitors at a location where they are exposed to direct sunlight or ultraviolet rays to prevent the LCD panels from deterioration by ultraviolet rays.
- 6) Do not stain or damage the contacts of the FPC cable .
FPC cable needs to be inserted until it can reach to the end of connector slot.
During insertion, make sure to keep the cable in a horizontal position to avoid an oblique insertion.
Otherwise, it may cause poor contact or deteriorate reliability of the FPC cable.
- 7) Do not bend or pull the FPC cable or carry the TFT monitor by holding the FPC cable.
- 8) Peel off the protective film on the TFT monitors during mounting process.
Refer to the section 14.5 on how to peel off the protective film.
We are not responsible for electrostatic discharge failures or other defects occur when peeling off the protective film.

14.3 Precautions for Operation

- 1) Since this TFT monitors are not equipped with light shielding for the driver IC, do not expose the driver IC to strong lights during operation as it may cause functional failures.
- 2) When turning off the power, turn off the input signal before or at the same timing of switching off the power.
- 3) Do not plug in or out the FPC cable while power supply is switch on.
Plug the FPC cable in and out while power supply is switched off.
- 4) Do not operate the TFT monitors in the strong magnetic field. It may break the TFT monitors.
- 5) Do not display a fixed image on the screen for a long time.
Use a screen-saver or other measures to avoid a fixed image displayed on the screen for a long time.
Otherwise, it may cause burn-in image on the screen due the characteristics of liquid crystal.

14.4 Storage Condition for Shipping Cartons

Storage environment

- Temperature 0 to 40° C
- Humidity 60%RH or less
No-condensing occurs under low temperature with high humidity condition.
- Atmosphere No poisonous gas that can erode electronic components and/or wiring materials should be detected.
- Time period 3 months
- Unpacking To prevent damages caused by static electricity, anti-static precautionary measures (e.g. earthing, anti-static mat) should be implemented.

- Maximum piling up (TBD) cartons

14.5 Precautions for Peeling off the Protective film

The followings work environment and work method are recommended to prevent the TFT monitors from static damage or adhesion of dust when peeling off the protective films.

A) Work Environment

- a) Humidity: 50 to 70 %RH, Temperature 15 to 27° C
- b) Operators should wear conductive shoes, conductive clothes, conductive finger tips and grounded wrist-straps. Anti-static treatment should be implemented to work area's floor.
- c) Use a room shielded against outside dust with sticky floor mat laid at the entrance to eliminate dirt.

B) Work Method

TBD

APPENDIX

Reference Method for Measuring Optical Characteristics and Performance

1. Measurement Condition

Measuring instruments: CS1000 (KONICA MINOLTA) , LCD7000(OTSUKA ELECTRONICS) ,EZcontrast160D (ELDIM)

Driving condition: Refer to the section "Optical Characteristics"

Measured temperature: 25° C unless specified

Measurement system: See the chart below. The luminance meter is placed on the normal line of measurement system.

Measurement point: At the center of the screen unless otherwise specified

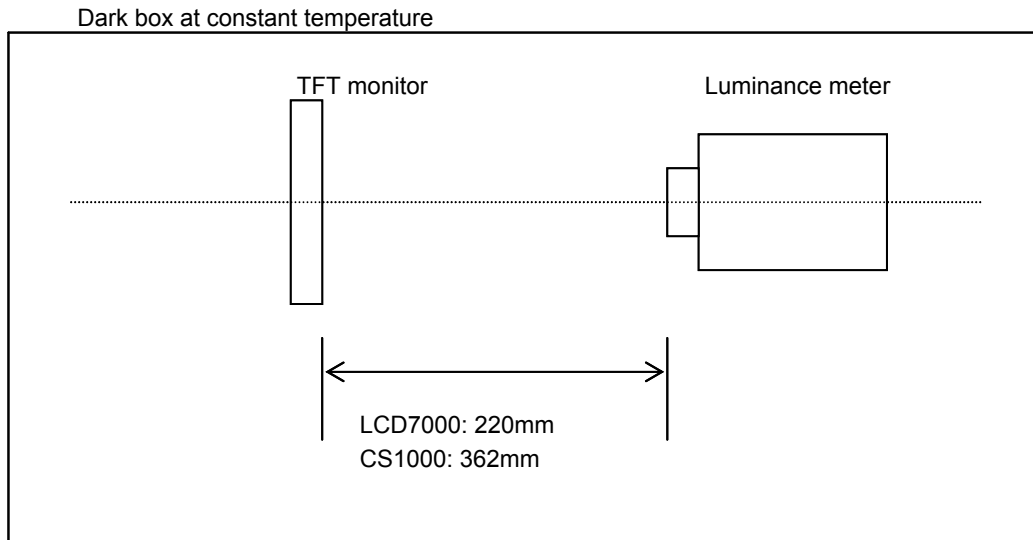

Measurement is made after 30 minutes of lighting of the backlight.

Measurement point: At the center point of the screen
Brightness distribution: 9 points shown in the following drawing.

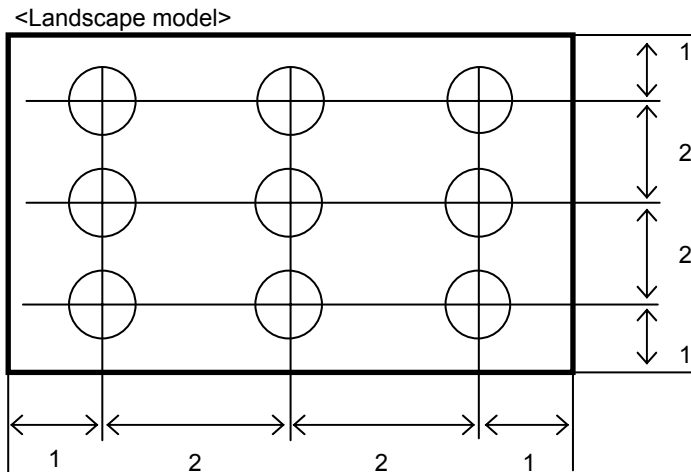

Dimensional ratio of active area

Backlight IL=20.0mA

2. Test Method

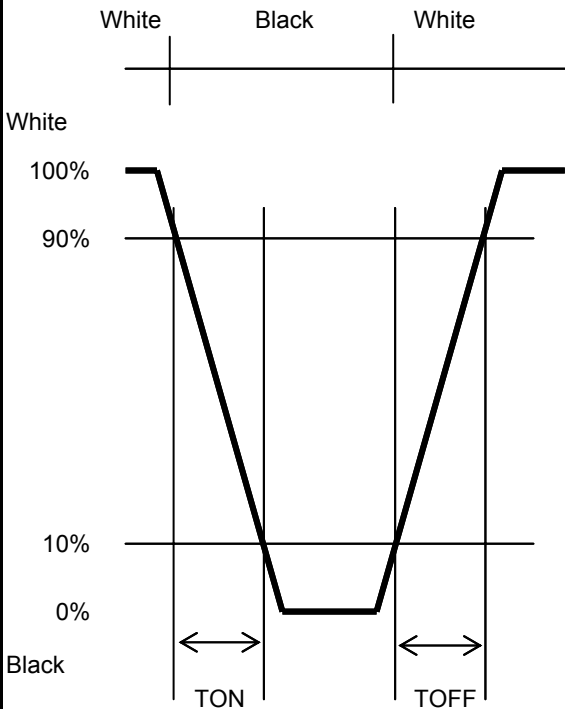
Notice	Item	Test method	Measuring instrument	Remark
1	Response time	<p>Measure output signal waveform by the luminance meter when raster of window pattern is changed from white to black and from black to white.</p> 	LCD7000	<p>Black display [Data]=(00)h White display [Data]=(3F)h TON Rise time TOFF Fall time</p>
2	Contrast ratio	<p>Measure maximum luminance Y1([Data]=(3F)h) and minimum luminance Y2([Data]=(00)h) at the center of the screen by displaying raster or window pattern. Then calculate the ratio between these two values.</p> <p>Contrast ratio = Y1/Y2</p> <p>Diameter of measuring point: 8mmφ</p>	CS1000	
3	Viewing angle Horizontalθ Verticalφ	<p>Move the luminance meter from right to left and up and down and determine the angles where contrast ratio is (10).</p>	EZcontrast160D	
4	White chromaticity	<p>Measure chromaticity coordinates x and y of CIE1931 colorimetric system at [Data] = (3F)h</p> <p>Color matching faction: 2°view</p>	CS1000	
5	Burn-in	<p>Visually check burn-in image on the screen after 2 hours of "window display" ([Data]=(3F)h)/(00)h).</p>		At optimized VCOMDC
6	Center brightness	<p>Measure the brightness at the center of the screen.</p>	CS1000	
7	Brightness distribution	<p>(Brightness distribution) = 100 x B/A %</p> <p>A : max. brightness of the 9 points</p> <p>B : min. brightness of the 9 points</p>	CS1000	