

PREPARED BY: DATE
N. Yasunishi
Dec. 9. 2009

SHARP[®]

SPEC No. LCP-05032F

FILE No.

CHECKED BY: DATE
T. Yabuuchi
Dec. 9. 2009

MOBILE LIQUID CRYSTAL DISPLAY GROUP
SHARP CORPORATION

ISSUE Dec. 9. 2009

PAGE Pages 22

APPLICABLE DIVISION

ENGINEERING DEPARTMENT III
MOBILE LCD DIVISION II
MOBILE LIQUID CRYSTAL DISPLAY
GROUP

SPECIFICATION

DEVICE SPECIFICATION for
TFT LCD Module
(176 × RGB × 220 dots)

Model No.

LQ022B8UD05

CUSTOMER'S APPROVAL

DATE _____

BY _____

PRESENTED
BY

T. Iemoto

Takaaki Iemoto

DEPARTMENT ASSISTANT GENERAL MANAGER
ENGINEERING DEPARTMENT III
MOBILE LCD DIVISION II
MOBILE LIQUID CRYSTAL DISPLAY GROUP
SHARP CORPORATION

NOTICE

- These specification sheets are the proprietary product of SHARP CORPORATION ("SHARP) and include materials protected under copyright of SHARP. Do not reproduce or cause any third party to reproduce them in any form or by any means, electronic or mechanical, for any purpose, in whole or in part, without the express written permission of SHARP.
- The application examples in these specification sheets are provided to explain the representative applications of the device and are not intended to guarantee any industrial property right or other rights or license you to use them. SHARP assumes no responsibility for any problems related to any industrial property right of a third party resulting from the use of the device.
- The device listed in these specification sheets was designed and manufactured for use in Telecommunication equipment (terminals)
- In case of using the device for applications such as control and safety equipment for transportation (aircraft, trains, automobiles, etc.), rescue and security equipment and various safety related equipment which require higher reliability and safety, take into consideration that appropriate measures such as fail-safe functions and redundant system design should be taken.
- Do not use the device for equipment that requires an extreme level of reliability, such as aerospace applications, telecommunication equipment (trunk lines), nuclear power control equipment and medical or other equipment for life support.
- SHARP assumes no responsibility for any damage resulting from the use of the device which does not comply with the instructions and the precautions specified in these specification sheets.
- Contact and consult with a SHARP sales representative for any questions about this device.

[For handling and system design]

- (1) Do not scratch the surface of the polarizer film as it is easily damaged.
- (2) If the cleaning of the surface of the LCD panel is necessary, wipe it swiftly with cotton or other soft cloth. Do not use organic solvent as it damages polarizer.
- (3) Water droplets on polarizer must be wiped off immediately as they may cause color changes, or other defects if remained for a long time.
- (4) Since this LCD panel is made of glass, dropping the module or banging it against hard objects may cause cracks or fragmentation.
- (5) Certain materials such as epoxy resin (amine's hardener) or silicone adhesive agent (de-alcohol or de-oxy) emits gas to which polarizer reacts (color change). Check carefully that gas from materials used in system housing or packaging do not hurt polarizer.
- (6) Liquid crystal material will freeze below specified storage temperature range and it will not get back to normal quality even after temperature comes back within specified temperature range. Liquid crystal material will become isotropic above specified temperature range and may not get back to normal quality. Keep the LCD module always within specified temperature range.
- (7) Do not expose LCD module to the direct sunlight or to strong ultraviolet light for long time.
- (8) If the LCD driver IC (COG) is exposed to light, normal operation may be impeded. It is necessary to design so that the light is shut off when the LCD module is mounted.
- (9) Do not disassemble the LCD module as it may cause permanent damage.
- (10) As this LCD module contains components sensitive to electrostatic discharge, be sure to follow the instructions in below.
 - ① Operators
Operators must wear anti-static wears to prevent electrostatic charge up to and discharge from human body.
 - ② Equipment and containers
Process equipment such as conveyer, soldering iron, working bench and containers may possibly generate electrostatic

charge up and discharge. Equipment must be grounded through 100Mohms resistance. Use ion blower.

③ Floor

Floor is an important part to leak static electricity which is generated from human body or equipment. There is a possibility that the static electricity is charged to them without leakage in case of insulating floor, so the countermeasure (electrostatic earth: $1 \times 10^8 \Omega$) should be made.

④ Humidity

Proper humidity of working room may reduce the risk of electrostatic charge up and discharge. Humidity should be kept over 50% all the time.

⑤ Transportation/storage

Storage materials must be anti-static to prevent causing electrostatic discharge.

⑥ Others

Protective film is attached on the surface of LCD panel to prevent scratches or other damages. When removing this protective film, remove it slowly under proper anti-ESD control such as ion blower.

(11) Hold LCD very carefully when placing LCD module into the system housing. Do not apply excessive stress or pressure to LCD module. Do not to use chloroprene rubber as it may affect on the reliability of the electrical interconnection.

(12) Do not hold or touch LCD panel to flex interconnection area as it may be damaged.

(13) As the binding material between LCD panel and flex connector mentioned in 12) contains an organic material, any type of organic solvents are not allowed to be used. Direct contact by fingers is also prohibited.

(14) When carrying the LCD module, place it on the tray to protect from mechanical damage. It is recommended to use the conductive trays to protect the CMOS components from electrostatic discharge. When holding the module, hold the Plastic Frame of LCD module so that the panel, COG and other electric parts are not damaged.

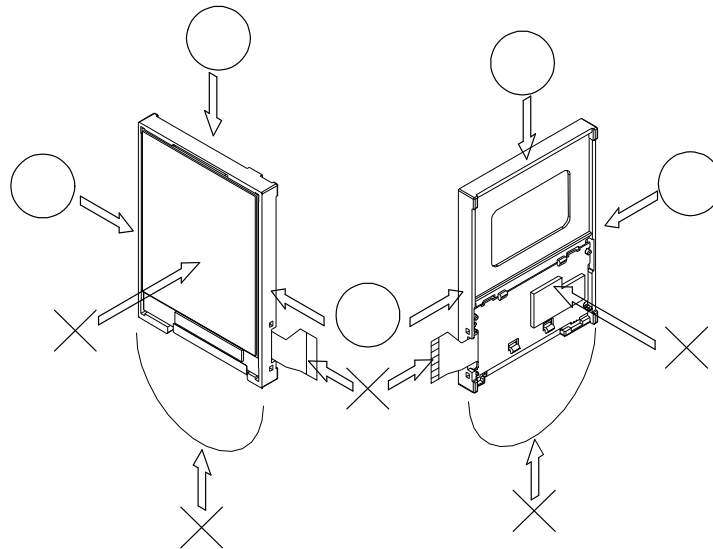

(15) Do not touch the COG's patterning area. Otherwise the circuit may be damaged.

(16) Do not touch LSI chips as it may cause a trouble in the inner lead connection.

(17) Place a protective cover on the LCD module to protect the glass panel from mechanical damages.

(18) LCD panel is susceptible to mechanical stress and even the slightest stress will cause a color change in background. So make sure the LCD panel is placed on flat plane without any continuous twisting, bending or pushing stress.

(19) Protective film is placed onto the surface of LCD panel when it is shipped from factory. Make sure to peel it off before assembling the LCD module into the system. Be very careful not to damage LCD module by electrostatic discharge when

peeling off this protective film. Ion blower and ground strap are recommended.

(20) Make sure the mechanical design of the system in which the LCD module will be assembled matches specified viewing angle of this LCD module.

(21) This LCD module does not contain nor use any ODS (1,1,1-Trichloroethane, CCL4) in all materials used, in all production processes.

[For operating LCD module]

(1) Do not operate or store the LCD module under outside of specified environmental conditions.

(2) Do not display still picture or the display over 2 hours as this will damage the liquid crystal.

(3) As opto-electrical characteristics of LCD will be changed, dependent on the temperature, the confirmation of display quality and characteristics has to be done after temperature is set at 25 °C and it becomes stable.

[Precautions for Storage]

(1) Do not expose the LCD module to direct sunlight or strong ultraviolet light for long periods. Store in a dark place.

(2) The liquid crystal material will solidify if stored below the rated storage temperature and will become an isotropic liquid if stored above the rated storage temperature, and may not retain its original properties. Only store the module at normal temperature and humidity (25±5°C, 60±10%RH) in order to avoid exposing the front polarizer to chronic humidity.

(3) Keeping Method

a. Don't keeping under the direct sunlight.

b. Keeping in the tray under the dark place.

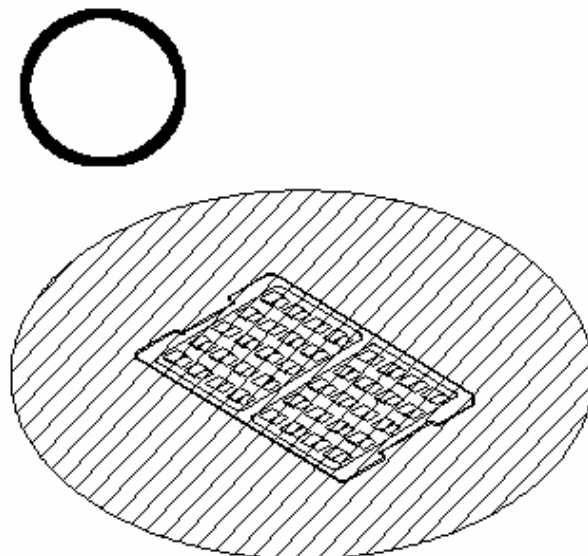
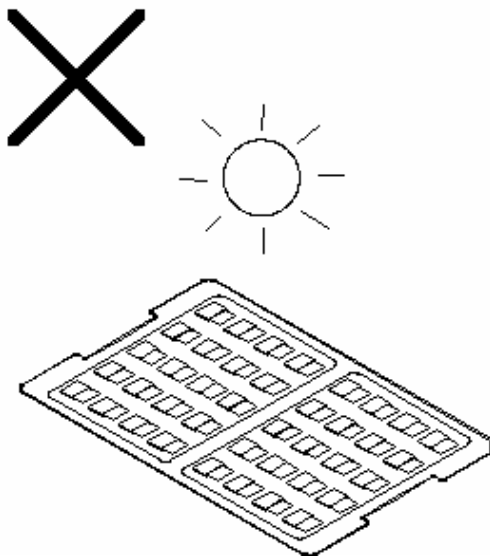

(4) Do not operate or store the LCD module under outside of specified environmental conditions.

(5) Be sure to prevent light striking the chip surface

[Other Notice]

- (1) Do not operate or store the LCD module under outside of specified environmental conditions.
- (2) As electrical impedance of power supply lines (VEE-VSS, VDD-VSS) are low when LCD module is working, place the de-coupling capacitor near by LCD module as close as possible.
- (3) Reset signal must be sent after power on to initialize LSI. LSI does not function properly until initialize it by reset signal.
- (4) Generally, at power on, in order not to apply DC charge directly to LCD panel, supply logic voltage first and initialize LSI logic function including polarity alternation. Then supply voltage for LCD bias. At power off, in order not to apply DC charge directly to LCD panel, execute Power OFF sequence and Discharge command.
- (5) Don't touch to PWB surface, exposed IC chip, electric parts and other parts, to any electric, metallic materials.
- (6) No bromide specific fire-retardant material is used in this module.
- (7) Because including CMOS in this model, there is possibility that this module works wrongly by the noise from the antenna and so on. Please implement enough shields on user's product.

[Precautions for Discarding Liquid Crystal Modules]

- COG : After removing the LSI from the liquid crystal panel, dispose of it in a similar way to circuit boards from electronic devices.
- LCD panel : Dispose of as glass waste. This LCD module contains no harmful substances. The liquid crystal panel contains no dangerous or harmful substances. The liquid crystal panel only contains an extremely small amount of liquid crystal (approx.100mg) and therefore it will not leak even if the panel should break.
- PWB/FPC : Dispose of as similar way to circuit board from electric device.

Contents	Page
I Notice	1
II Contents	5
1. Application	6
2. Construction and Outline	6
3. Mechanical specification	6
4. Absolute Maximum Ratings	7
(4-1) Electrical absolute maximum ratings	7
(4-2) Environment Conditions	7
5. Electrical specification	8
(5-1) Electrical characteristics	8
(5-2) LED back light	9
(5-3) Interface signals	10
(5-4) Host Interface timing	11~12
(5-5) Electrical Schematics of LCD	13
(5-6) Power ON/OFF sequence	14~15
6. Optical characteristics	16~18
7. Lot Number identification	19
8. Packing specifications	19
(8-1) Details of packing	19
(8-2) Reliability	19
(8-3) Packing quantities	20
(8-4) Packing weight	20
(8-5) Packing outline dimensions	20~21
9. LCD module outline	22

1. Application

This data sheet is to introduce the specification of LQ022B8UD05, active matrix 262,144 colors LCD module. The LCD module controlled by Driver ICs (LR38825 / LH169CH).

If any problem occurs concerning the items not stated in this specification, it must be solved sincerely by both parties after deliberation.

As to basic specification of driver IC refer to the IC specification and handbook.

2. Construction and Outline

Construction: LCD panel, Driver (COG), FPC with electric components, 4 pieces White LED lump, prism sheet, diffuser, light guide and reflector, plastic frame to fix them mechanically.

Outline: See Fig.12 (page 22).

Connection: 35 pins; 0.3mm pitch ZIF FPC connector. Correspondable connector: FF02B35SS1 (JAE)

3. Mechanical Specification

Table 1

Parameter		Specifications	Unit
Outline dimensions *1		42.1 (W) × 56.6 (H) × 4.2 (D)	mm
LCD Panel	Active area	34.848 (W) × 43.56 (H)	mm
	Display format	176×RGB(W)×220(H)	-
	Dot pitch	0.066 (W) × 0.198 (H)	mm
	Base color *2	Normally white	-
Mass		Approx 12.1	g

*1 See Fig.12 (page 22)

*2 Due to the characteristics of the LC material, the colors vary with environmental temperature.

4. Absolute Maximum Ratings
(4-1) Electrical absolute maximum ratings

Table 2

Ta=25°C

Parameter	Symbol	Min	Max	Unit	Remark
Supply voltage for LCD	VEE-VSS	-0.3	4.0	V	VEE
Supply voltage for Logic	VDD-VSS	-0.3	4.0	V	VDD
Input Voltage	V _{IN}	-0.3	VDD+0.3	V	*1
LED forward current	I _{LED}	0	30	mA	*2

*1 Input terminal of logic system. : Voltage value is based on VSS = 0V.

*2 See (5-2) LED back light (page 9)

(4-2) Environment Conditions

Table 3

Item	Top		Tstg		Remark
	MIN.	MAX.	MIN.	MAX.	
Ambient temperature	-10 °C	+60°C	-20 °C	+70°C	Note 2)
Humidity	Note 1)		Note 1)		No condensation

Note1) Ta ≤ 40 °C.....95 % RH Max

Note2) Ta > 40 °C.....Absolute humidity shall be less than Ta=40 °C /95 % RH.

As opt-electrical characteristics of LCD will be changed, dependent on the temperature, the confirmation of display quality and characteristics has to be done after temperature is set at 25 °C and it becomes stable. Be sure not to exceed the rated voltage, otherwise a malfunction may occur.

5. Electrical Specifications
 (5-1) Electrical characteristics

Table 4

Ta=25°C, VEE=3.0V, VDD=3.0V, VSS=0V

Parameter	Symbol	Conditions	Min.	Typ.	Max.	Unit	Applicable Pin
Supply voltage for LCD	VEE-VSS	Ta=-10~60 °C	2.8	3.0	3.2	V	VEE
Supply voltage for Logic	VDD-VSS	Ta=-10~60 °C	1.7	3.0	3.6	V	VDD
"H" level input voltage	V _{IH}	Ta=-10~60 °C	0.7VDD	-	-	V	(note1)
"L" level input voltage	V _{IL}		-	-	0.3VDD	V	
"H" level Input leakage current	I _{IH}	Ta=-10~60 °C V _{IN} = VSS or VDD	-	-	10	μA	(note2)
"L" level Input leakage current	I _{IL}		-10	-	-	μA	
"H" level output voltage	V _{OH}	Ta=-10~60 °C I _{OH} =-100μA, I _{OL} =100μA	0.8VDD	-	-	V	(note3)
"H" level output voltage	V _{OL}		-	-	0.2VDD	V	
Current consumption for LCD	I _{EE}	Ta=25 °C	-	5.5	8.0	mA	(note4)
Current consumption for Logic	I _{DD}		2.0	10.0	μA		

(note1) /WR, /CS, RS, /RD, /RES, D0~D15

(note2) /WR, /CS, RS, /RD, /RES, D0~D15

(note3) LCDINT

(note4) Following Conditions

Ta=25 °C, VDD=3.0V, VEE=3.0V, Frame frequency = 80Hz

Display Pattern: All Black. No Host CPU access.

*All Black pattern

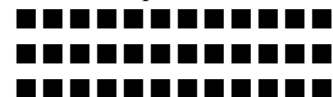

(5-2) LED back light

(1) At LCD panel, the back light use 4pieces white LED.

Table 5

Parameter	Symbol	Conditions	Min.	Typ.	Max.	Unit	Remark
Forward current	I_{LED}	Ta=25 °C	-	20	30	mA	CA

LED maker : NICHIA Corporation

LED type : NSSW008CT

*Please consider Allowable Forward Current on used temperature
(refer to Ambient Temperature vs. Allowable Forward Current curve)

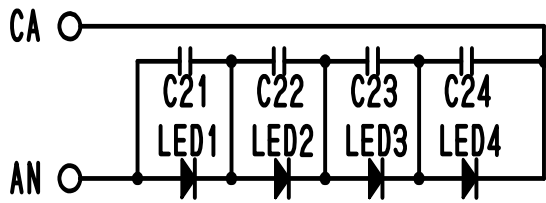

C21~C24 : 0.1 μ F / 10V

Fig.1 LED circuit

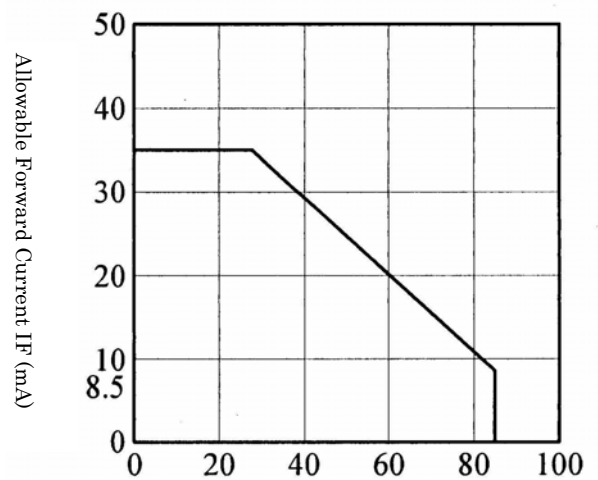

Ambient Temperature (°C)

Fig.2 Ta vs. IF (NSSW008CT)

<SPECIFICATIONS>

(1) Absolute Maximum Ratings Table 6 (Ta=25°C)

Item	symbol	MAX	unit
Forward Current	IF	35	mA
Pulse Forward Current	IFP	100	mA
Reverse Voltage	$\theta y-$	5	V
Power Dissipation	$\theta y+$	123	mW

(2) Initial Electrical / Optical Characteristics Table 7 (Ta=25°C)

Item	Symbol	Condition	MIN	TYP	MAX	unit
Forward Voltage	VF	IF=20mA	-	(3.2)	3.5	V
Reverse Current	IR	VR=5V		-	50	μ A

(5-3) Interface signals

Table 8

Pin No	Symbol	Description	I/O	Remark	
1	VSS	Ground level pin	-	-	
2	VSS	Ground level pin	-	-	
3	VEE	VEE level pin	-	For LCD driving	
4	D15	Data Bus (MSB)	I/O	(Note 1)	
5	D14	Data Bus	I/O	(Note 1)	
6	D13	Data Bus	I/O	(Note 1)	
7	D12	Data Bus	I/O	(Note 1)	
8	D11	Data Bus	I/O	(Note 1)	
9	D10	Data Bus	I/O	(Note 1)	
10	D9	Data Bus	I/O	(Note 1)	
11	D8	Data Bus	I/O	(Note 1)	
12	VSS	Ground level pin	-	-	
13	D7	Data Bus	I/O		
14	D6	Data Bus	I/O		
15	D5	Data Bus	I/O		
16	D4	Data Bus	I/O		
17	D3	Data Bus	I/O		
18	D2	Data Bus	I/O		
19	D1	Data Bus	I/O		
20	D0	Data Bus (LSB)	I/O		
21	VSS	Ground level pin	-		
22	VSS	Ground level pin	-		
23	/WR	Write control input pin	I	"L" active	
24	RS	Register select pin	I		
25	/CS	Chip select input pin	I	"L" active	
26	/RES	Reset signal input pin	I	"L" active	
27	VDD	VDD level pin	-	For Logic driving	
28	LCDINT	Interrupt request to the host bus	O	(Note 2)	
29	/RD	Read control input pin	I	"L" active	
30	IFM0	Selection signal pin for host interface mode	I	L	RS "H" : commands
				H	RS "L" : commands
31	BUS0	Selection signal pin for the width of data bus	I	L	8bit bus interface
				H	16bit bus interface
32	AN	LED back light for (Anode)	-	-	
33	AN	LED back light for (Anode)	-	-	
34	CA	LED back light for (Cathode)	-	-	
35	CA	LED back light for (Cathode)	-	-	

Used connection : 0.3mm pitch ZIF FPC connector.

Correspondable connector : FF02B35SS1 (JAE)

(Note 1) For unused Data Bus, connect to VSS.

(Note 2) If don't use "LCDINT" pin, leave it open.

(5-4) Host Interface Timing

(1) Write

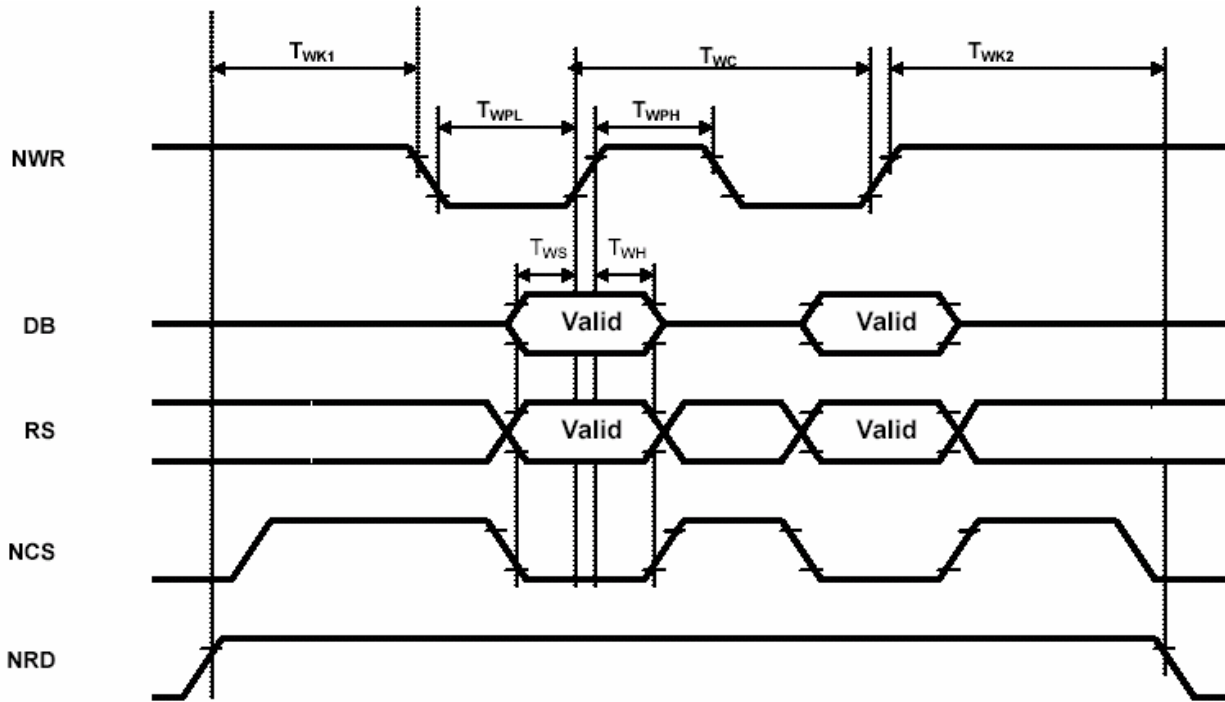

Fig.3 Host interface timing (Write)

Table 9

Symbol	Description	Min.	Max.	Note
T_{WPL}	Low period of NWR	60 ns	-	
T_{WPH}	High period of NWR	80 ns	-	
T_{WC}	Prohibit time re-writing	140 ns	-	
T_{WS}	Set up time of DB, RS and NCS to the NWR rising.	50 ns	-	
T_{WH}	Hold time of DB, RS and NCS to the NWR rising.	0 ns	-	
T_{WK1}	Required time from the read cycle to write cycle	300 ns	-	
T_{WK2}	Required time from the write cycle to read cycle	300 ns	-	

Conditions: $V_{DDIOH} = 1.65 \text{ V to } 3.3 \text{ V}$, $V_{DDCORE} = 1.8 \pm 0.15 \text{ V}$, $T_{opr} = -30^\circ\text{C to } +70^\circ\text{C}$, $C_L = 10 \text{ pF}$

Reference input voltage: $V_{IH} = 0.9 V_{DDIOH}$, $V_{IL} = 0.1 V_{DDIOH}$

Reference output voltage: $V_{OH} = 0.9 V_{DDIOH}$, $V_{OL} = 0.1 V_{DDIOH}$

(2) Read

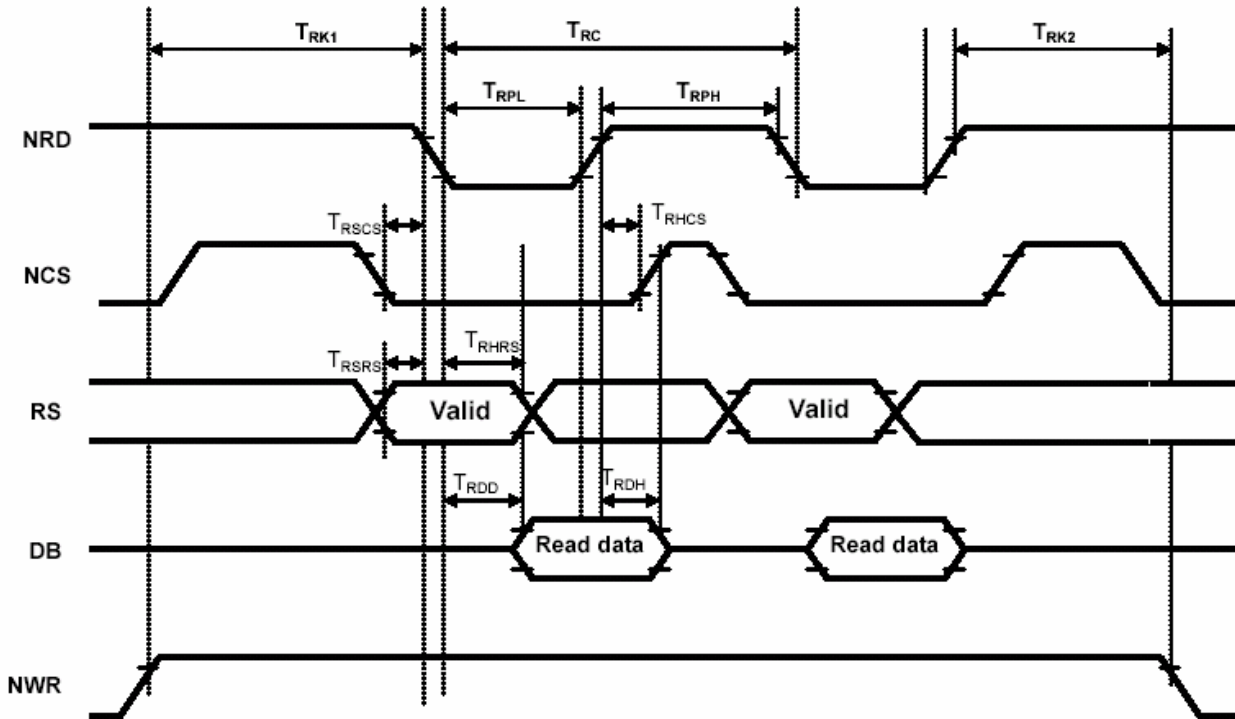

Fig.4 Host interface timing (Read)

Table 10

Symbol	Description	Min.	Max.
T_{RPL}	Low period of NRD	100ns	-
T_{RPH}	High period of NRD	100ns	-
T_{RC}	Prohibition time for re-reading	200ns	-
T_{RSRS}	Set up time of RS to NRD falling	50ns	-
T_{RSCS}	Set up time of NCS to NRD falling	50ns	-
T_{RHRS}	Hold time of RS from NRD falling	50ns	-
T_{RHCS}	Hold time of NCS from NRD rising	50ns	-
T_{RDD}	Time from NRD falling to confirmation of DB output	-	80ns
T_{RDH}	Time from NRD rising to confirmation of DB output	5ns	-

Conditions: $V_{DDIOH} = 1.65\text{ V to }3.3\text{ V}$, $V_{DDCORE} = 1.8 \pm 0.15\text{ V}$, $T_{opr} = -30^{\circ}\text{C to }+70^{\circ}\text{C}$, $C_L = 10\text{ pF}$

Reference input voltage: $V_{IH} = 0.9 V_{DDIOH}$, $V_{IL} = 0.1 V_{DDIOH}$

Reference output voltage: $V_{OH} = 0.9 V_{DDIOH}$, $V_{OL} = 0.1 V_{DDIOH}$

(5-5) Schematic of LCD module system

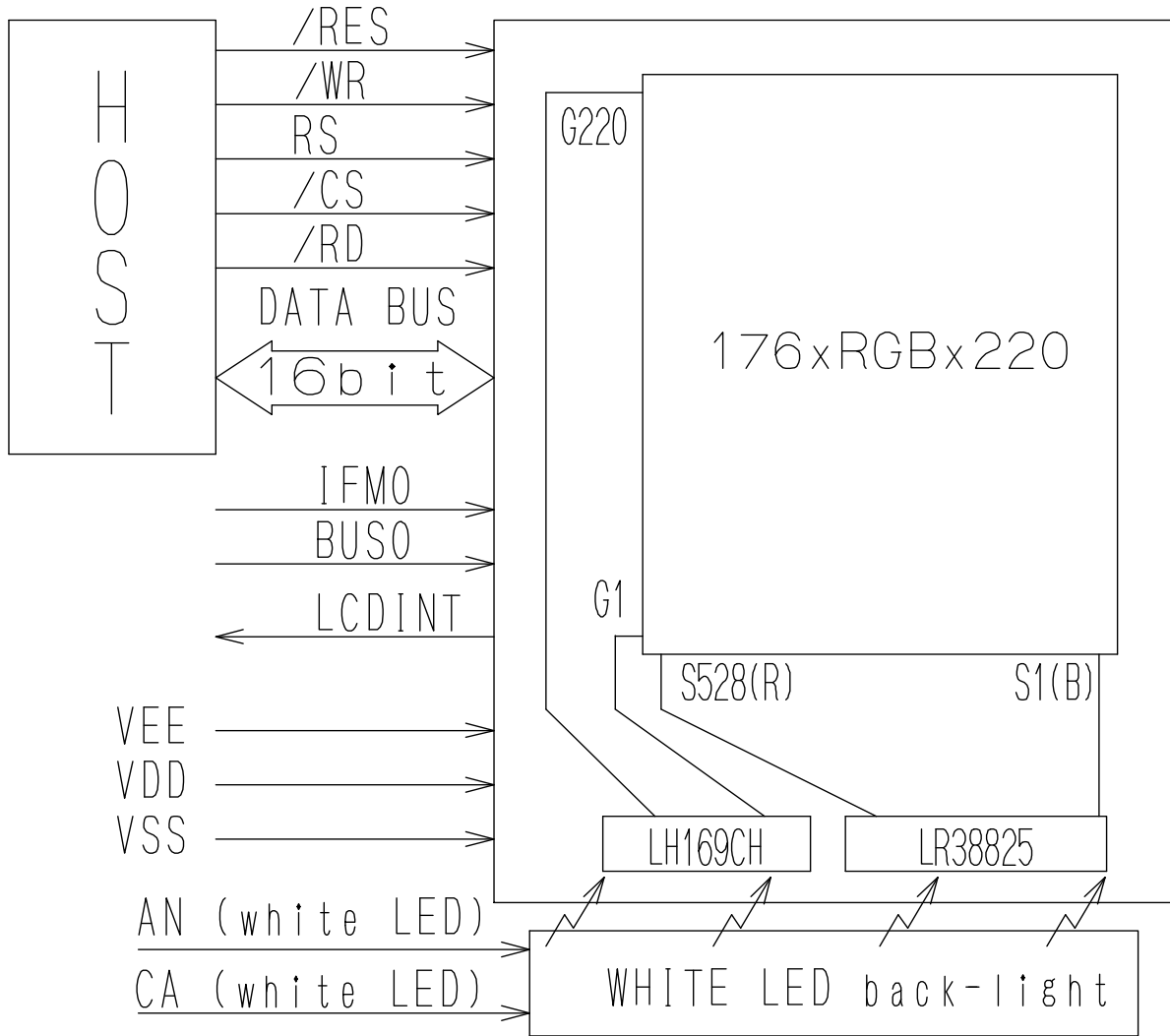

Fig.5 Schematic of LCD module system

(5-6) Power ON/OFF sequence

(1) Power ON

Table 11

Register	Command	Remarks
FD	FD	Software reset
FD	FD	
		WAIT (Min 50ms)
E0	01	Gate reset
		WAIT (Min 5 μ s)
E0	00	Gate reset release
FE	FE	Host reset
FE	FE	
EE	00	EEPROM I/F ready [Note]
		WAIT (Min 10ms)
EF	00	CPU bank active
10	08	Host Interface setting register (1)
12	AF	VRAM access area setting register (X direction/start and pointer)
13	DB	VRAM access area setting register (Y direction/start and pointer)
15	00	VRAM access area setting register (X direction/end)
16	00	VRAM access area setting register (Y direction/end)
18	03	Address auto increment setting register
88	00	Display displaying color setting register
7E	04	Display displaying setting register
		WAIT (Min 20ms)
7E	05	Display displaying setting register
7F	01	V sync parameter transfer flag
		【Write VRAM】
80	01	Display displaying control register (DIPS ON)

[Note]

A setup peculiar value to a panel is written in EEPROM.

【Cautions】 Please do not rewrite

(2) Power OFF



Table 12

Register	Command	Remarks
EF	00	CPU bank active
1B	04	Host reset enable
FE	FE	Host reset
FE	FE	
7E	04	Display setting
		WAIT (MIN 100ms)
E3	04	Dc setting
E4	04	Dc setting
E2	01	Dc off setting
80	00	Display Off
		WAIT (MIN 100ms)
E0	01	Gate reset
7F	01	TG parameter refresh
		WAIT (MIN 5 μ s)
E0	00	Gate reset release
7F	01	TG parameter refresh
		WAIT (MIN 5 μ s)
01	01	Oscillator stop
		【Power off】

6. Optical Characteristics

Table 13

Ta = 25°C

Mode	parameter	symbol	conditio n	MIN	TYP	MAX	unit	Remark	
Transmissive	Brightness	B	$\theta=0^\circ$	88	125	-	cd/m ²	Note 1,2	
	Contrast	Co	$\theta=0^\circ$	40:1	60:1	-		Note 1,3	
	Viewing Angle	θ_{y-}	Co > 5	$\theta=0^\circ$	20	30	-	deg	Note 1
		θ_{y+}			20	30	-		
		θ_{x-}			20	30	-		
		θ_{x+}			20	30	-		
	Response Time	Rise	τ_{r1}	$\theta=0^\circ$	-	18	35	ms	Note 1,4
Decay		τ_{d1}	-		45	75	ms		
White chromaticity	x	y	$\theta=0^\circ$	-	0.31	-		Note 1,3	
	y			-	0.35	-			
Reflective	Reflectance	Rf	$\theta=0^\circ$	-	11	-	%	Note 5	
	White chromaticity	x	$\theta=0^\circ$	-	0.30	-		Note 5	
		y		-	0.34	-			

Note 1) Definition of range of visual angle

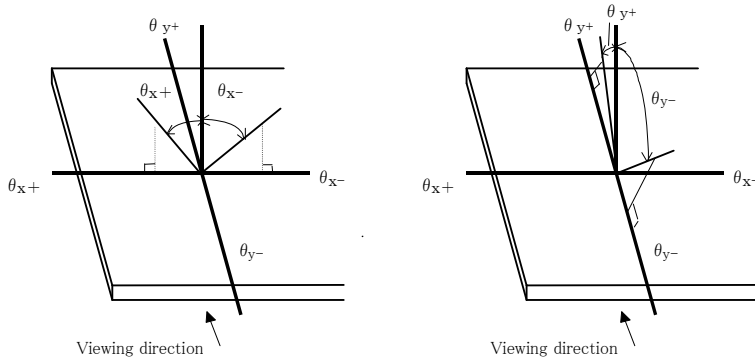

Fig.6 Definition of viewing angle

Note 2) Brightness is measured as shown in Fig.7, and is defined as the brightness of all pixels “White” at the center of display area on optimum contrast.

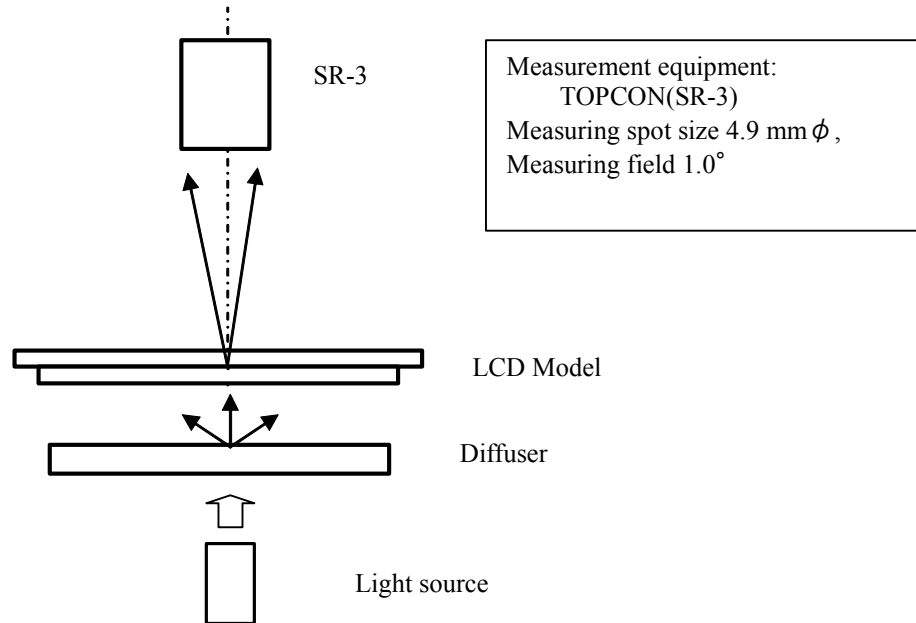

Fig.7 Optical characteristics Test Method (Brightness)

Note 3) Contrast ratio is defined as follows:

$$C_o = \frac{\text{Luminance(brightness) all pixels "White"}}{\text{Luminance(brightness) all pixels "dark"}}$$

Note 4) Response time is defined as follows:

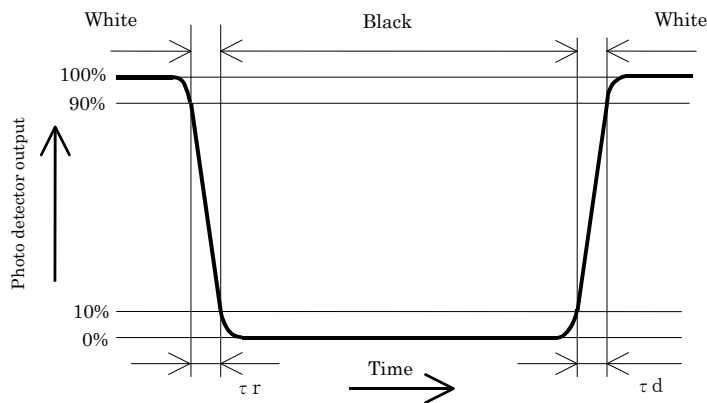

Fig.8 Response time (TFT)

Note 5) Reflectance is defined as follows:

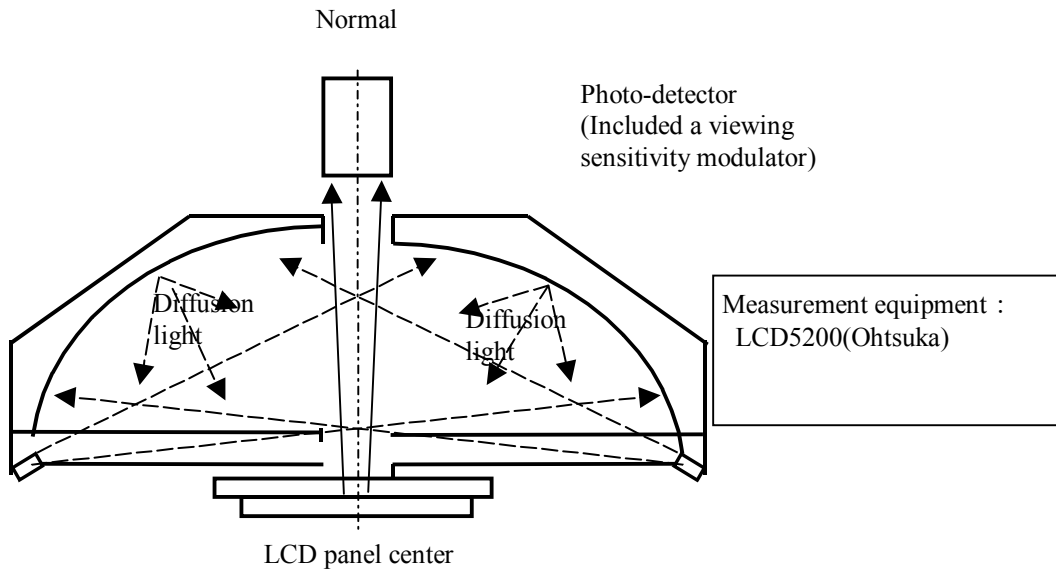
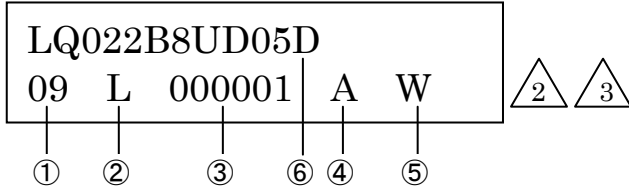

Fig.9 Optical Characteristics Test Method

7. Lot Number identification

Lot numbering and location are specified as follows.



① product year (lower 2 digits)

09:2009, 10:2010,

② product month

A: JANUARY, B: FEBRUARY, C: MARCH,, L: DECEMBER

③ Serial number

000001 ~ 999999

④ Record of Revision △2

A:1st revision, B:2nd revision, C:3rd revision,

⑤ Product maker

W: SHARP

⑥ Composition parts management code △5

A, B, C, D, ...

8. Packing specifications

(8-1) Details of packing

1) Packing materials :Table.15

2) Packing style :Fig.11

(8-2) Reliability

1) Vibration test

Table.14

Item	Test			
Frequency	5 Hz to 50 Hz (3 minutes cycle)			
Direction	Up-Down, Left-Right, Front-Back (3 directions)			
Period	Up-Dow	Left-Right	Front-Back	Total
	60min	15min	15min	90min

The frequency should start at 5 Hz and vary continuously.

Total amplitude 20mm 0.2mm 20mm 0.2mm

Frequency 5Hz 50Hz 5Hz 50Hz (For 9.8m/s²)

○ ○ ○
| ← 3 minutes → |

2) Drop test

Drop height: 750mm

Number of drop: 10timers (Ddrop sequence: 1 corner, 3 edges, 6 faces)

(8-3)Packing quantities

250 modules (max) per master carton

(8-4)Packing weight

About 7.7kg

(8-5)Paking outline dimensions

382mm × 578mm × 255mm

(Packing materials)

Table.15

	Parts name	Materials
1	Master carton	Corrugate card board
2	Under pad	Corrugate card board
3	Inside sleeve	Corrugate card board
4	Outside sleeve	Corrugate card board
5	Tray for packing	Polystyrene with anti-static treatment +anti-static polystyrene
6	OPP tape	Polypropylene
7	Protective bag	Polyethylene with anti-static treatment +anti-static polyethylene

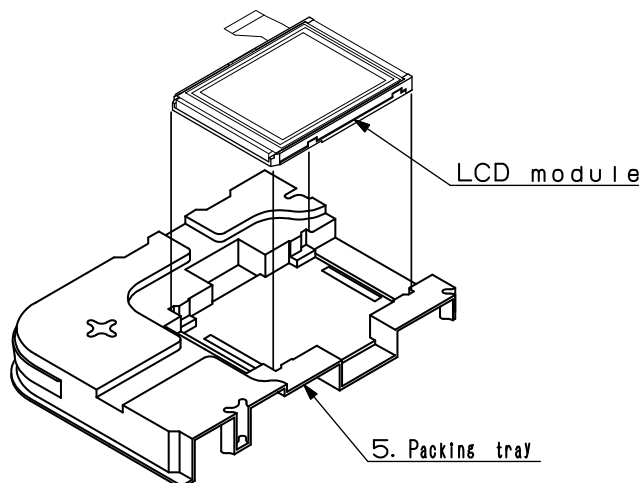

Fig.10

TYPE	社内品番: (4S) LQ022B8UD05 D
	LotNO. : (1T) 2009, xx, xx
QUANTITY	Quantity: (Q) 250 PCS
LOT (DATE)	ユーザー品番: _____
シャープ製造用ラベルです。() ()	

【Quantities】

- 1 tray : 25 modules (MAX)
- 1 sleeve: 125 modules (MAX)
- 1 carton: 250 modules (MAX)

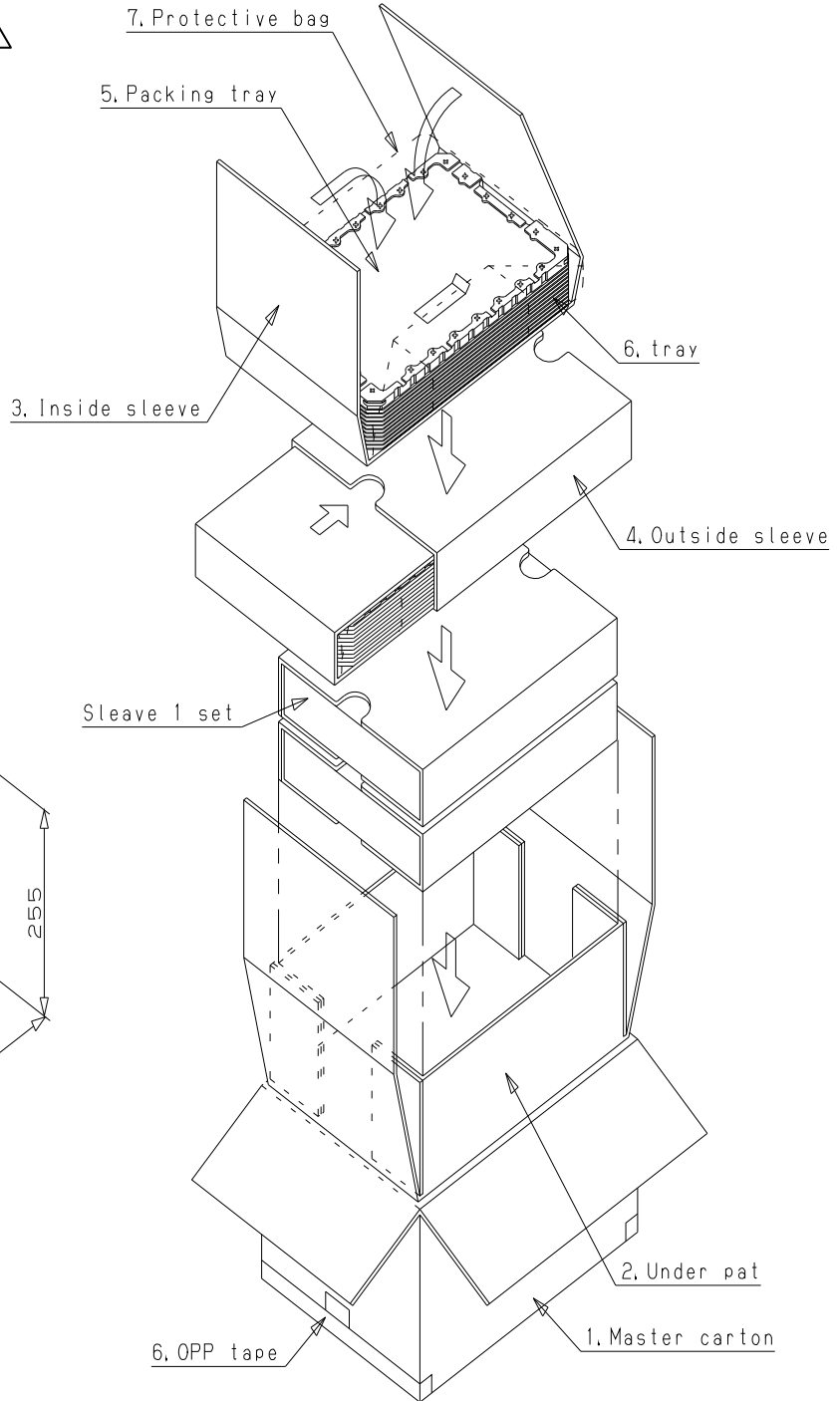
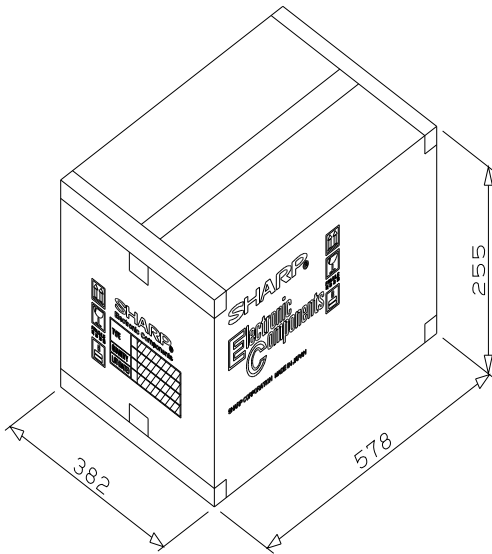

Fig.11

9. LCD module outline

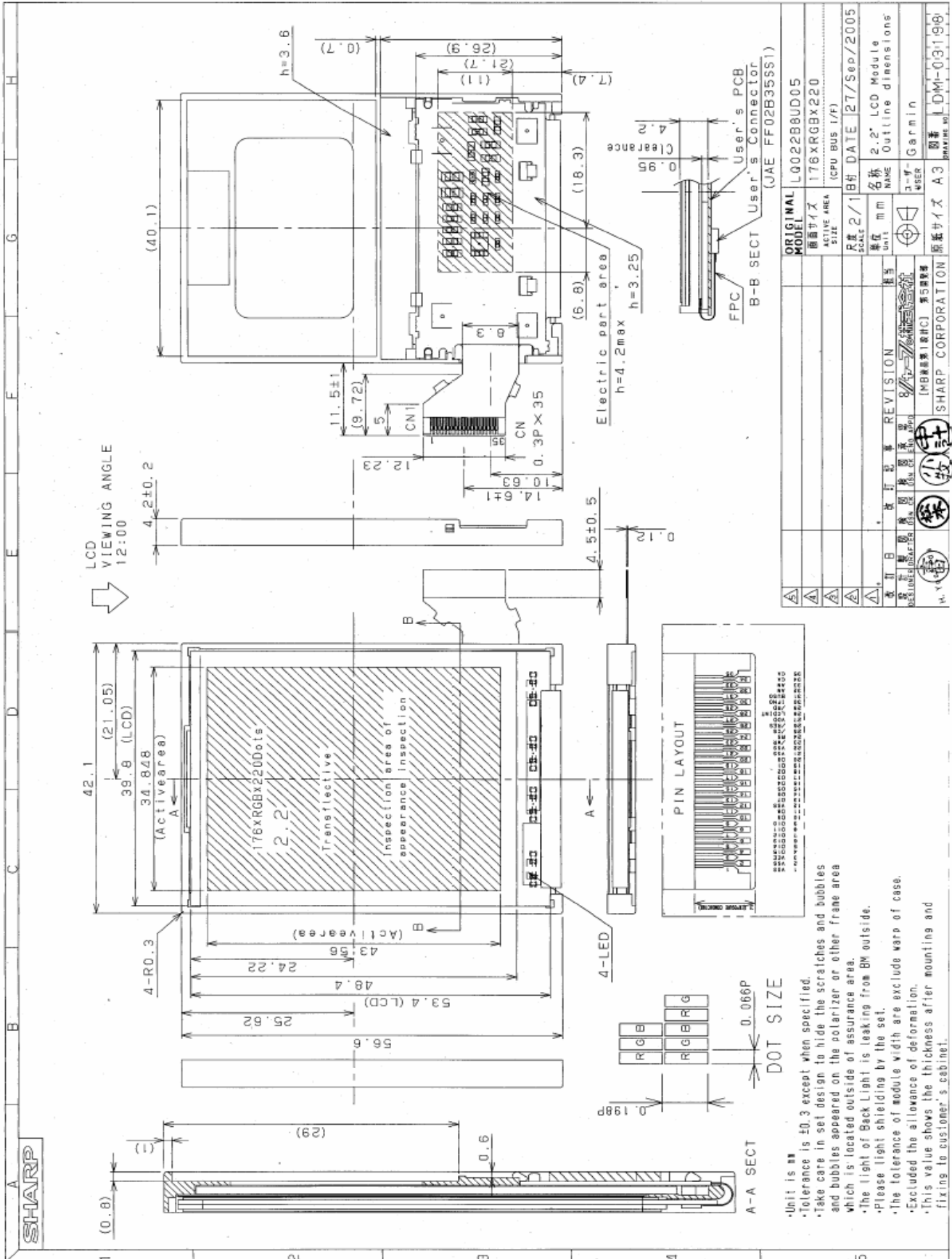

Fig. 12

- Unit is mm
- Tolerance is ±0.3 except when specified.
 - Take care in set design to hide the scratches and bubbles and bubbles appeared on the polarizer or other frame area which is located outside of assurance area.
 - The light of Back Light is leaking from BM outside.
 - Please light shielding by the set.
 - The tolerance of module width are exclude warp of case.
 - Excluded the allowance of deformation.
 - This value shows the thickness after mounting and fixing to customer's cabinet.