

PREPARED BY: DATE	<p style="text-align: center;">SHARP[®]</p> <p style="text-align: center;">MOBILE LIQUID CRYSTAL DISPLAY GROUP SHARP CORPORATION</p> <p style="text-align: center;">SPECIFICATION</p>	SPEC No. LCY-W-06602A
APPROVED BY: DATE		FILE No.
		ISSUE Jul.21.2006
		PAGE Pages 24
		APPLICABLE DIVISION MOBILE LCD CHINA DESIGN CENTER WUXI SHARP

DEVICE SPECIFICATION for
 TFT LCD Module
 (480 × RGB × 272 dots)

 Model No.
LQ043T1DG01

CUSTOMER'S APPROVAL

DATE _____

BY _____

PRESENTED BY

K. Yamamoto

YAMAMOTO.KUNIHICO

GENERAL MANAGER
MOBILE LCD CHINA DESIGN CENTER
WUXI SHARP

NOTICE

This publication is the proprietary of SHARP and is copyrighted, with all rights reserved. Under the copyright laws, no part of this publication may be reproduced or transmitted in any form or by any means, electronic or mechanical for any purpose, in whole or in part, without the express written permission of SHARP. Express written permission is also required before any use of this publication may be made by a third party.

The application circuit examples in this publication are provided to explain the representative applications of SHARP's devices and are not intended to guarantee any circuit design or permit any industrial property right or other rights to be executed. SHARP takes no responsibility for any problems related to any industrial property right or a third party resulting from the use of SHARP's devices, except for those resulting directly from device manufacturing processes.

In the absence of confirmation by device specification sheets, SHARP takes no responsibility for any defects that occur in equipment using any of SHARP's devices, shown in catalogs, data books, etc. Contact SHARP in order to obtain the latest device specification sheets before using any SHARP's device.

SHARP reserves the right to make changes in the specifications, characteristics, data, materials, structures and other contents described herein at any time without notice in order to improve design or reliability. Contact SHARP in order to obtain the latest specification sheets before using any SHARP's device. Manufacturing locations are also subject to change without notice.

Observe the following points when using any device in this publication. SHARP takes no responsibility for damage caused by improper use of the devices.

The devices in this publication are designed for use in general electronic equipment designs, such as:

- Personal computers ·Office automation ·Telecommunication equipment
- Test and measurement equipment ·Industrial control ·Personal digital assistant
- Audio visual and multimedia equipment ·Consumer electronics

The appropriate design measures should be taken to ensure reliability and safety when SHARP's devices are used for equipment such as:

- Transportation control and safety equipment (i.e., aircraft, trains, automobiles, etc.)
- Traffic signals ·Gas leakage sensor breakers
- Alarm equipment ·Various safety devices etc.

SHARP's devices shall not be used for equipment that requires extremely high level of reliability, such as:

- Military and space applications ·Nuclear power control equipment
- Medical equipment for life support

Contact a SHARP representative, in advance, when intending to use SHARP's devices for any "specific" applications other than those recommended by SHARP.

Contact and consult with a SHARP representative if there are any questions about the contents of this publication.

1. Applicable Scope

This specification is applicable to TFT-LCD Module “LQ043T1DG01”.

2. General Description

This module is a color active matrix LCD module incorporating amorphous silicon TFT (Thin Film Transistor). It is composed of a color TFT-LCD panel, driver ICs, Input FPC, a back light unit and a touch panel. Graphics and texts can be displayed on a 480×3×272 dots panel with about 16million colors by supplying 24bit data signals(8bit×RGB), Four timing signals, logic (typ. +3.3V), analog (typ. +5V) supply voltages for TFT-LCD panel driving and supply voltage for back light.

3. Mechanical (Physical) Specifications

Item	Specifications	Unit
Screen size	10.9 (4.3" type) diagonal	cm
Active area	95.04(H)×53.856(V)	mm
Pixel format	480(H)×272(V)	pixel
	1 Pixel =R+G+B dots	-
Pixel pitch	0.198(H)×0.198(V)	mm
Pixel configuration	R,G,B vertical stripes	-
Display mode	Normally white	-
Unit outline dimensions	105.5(W)×67.2(H)×5.05(D)	mm
Mass	Approx. 62	g
Surface treatment	Anti-glare, 2H	-

※ The above-mentioned table indicates module sizes without some projections and FPC.
For detailed measurements and tolerances, please refer to Fig.1.

4. Input Terminal Names and Functions

4-1. TFT LCD Panel Driving (Reference Connector: Hirose Electric CO., LTD. Product No.: FH12A-40S-0.5SH (55) Top contact type)

※ The Bottom contact type can be selected according to side of mounted connector and terminal side of FPC.

Terminal No.	Terminal name	Function	Remarks
1	GND	GND(0V)	
2	GND	GND(0V)	
3	VCC	+3.3V power source	
4	VCC	+3.3V power source	
5	R0	RED Data Signal (LSB)	
6	R1	RED Data Signal	
7	R2	RED Data Signal	
8	R3	RED Data Signal	
9	R4	RED Data Signal	
10	R5	RED Data Signal	
11	R6	RED Data Signal	
12	R7	RED Data Signal (MSB)	
13	G0	GREEN Data Signal (LSB)	
14	G1	GREEN Data Signal	
15	G2	GREEN Data Signal	
16	G3	GREEN Data Signal	
17	G4	GREEN Data Signal	
18	G5	GREEN Data Signal	
19	G6	GREEN Data Signal	
20	G7	GREEN Data Signal (MSB)	
21	B0	BLUE Data Signal (LSB)	
22	B1	BLUE Data Signal	
23	B2	BLUE Data Signal	
24	B3	BLUE Data Signal	
25	B4	BLUE Data Signal	
26	B5	BLUE Data Signal	
27	B6	BLUE Data Signal	
28	B7	BLUE Data Signal (MSB)	
29	GND	GND(0V)	
30	CK	Clock signal to sample each date	
31	DISP	Display ON/OFF Signal	
32	Hsync	Horizontal synchronizing signal	
33	Vsync	Vertical synchronizing signal	
34	NC	NC	Note 1
35	AVDD	+5V Analog power source	
36	AVDD	+5V Analog power source	
37	NC	NC	Note 1
38	TEST1	TEST1	Note 2
39	TEST2	TEST2	Note 3
40	TEST3	TEST3	Note 3

Note 1) They have been open within FPC.

Note 2) Please be sure to set 38 pins (TEST1) to open.

Note 3) Please be sure to connect 39 pin (TEST2), 40 pin (TEST3) with GND.

4-2. Backlight

0.5mmP 4Pin FPC (Reference Connector: Kyocera Elco Corporation Product No.: 6298 Bottom contact type)

※ The Bottom contact type can be selected according to side of mounted connector and terminal side of FPC.

Terminal No.	Signal	Function
1	VLED-	LED Power Source Input terminal (Cathode side)
2	NC	No Connection
3	NC	No Connection
4	VLED+	LED Power Source Input terminal (Anode side)

4-3.Touch panel

1mmP 4Pin FPC (Reference Connector: J.S.T. Mfg Co., Ltd, Product No.: 0.4(1.0)9FLH-SM1-GB-TB)

Terminal No.	Terminal name	Description
T1	YU	Y (12 o'clock side)
T2	XL	X (left side)
T3	YD	Y (6 o'clock side)
T4	XR	X (right side)

5. Absolute Maximum Ratings

Item	Symbol	Conditions	Rated value	Unit	Remarks
Input voltage	V_I	Ta=25°C	-0.3 ~ VCC+0.3	V	【Note 1】
3.3 V Power supply voltage	VCC	Ta=25°C	0 ~ +4.5	V	
5 V Power supply voltage	AVDD	Ta=25°C	0 ~ +6.0	V	
Temperature for storage	T _{stg}	-	-30 ~ +85	°C	【Note 2】
Temperature for operation	T _{opr}	-	-10 ~ +70	°C	【Note 3】
LED Input electric current	I _{LED}	Ta=25°C	35	mA	【Note 4】
LED electricity consumption	P _{LED}	Ta=25°C	123	mW	【Note 4】

【Note 1】 CK,R0~R7,G0~G7,B0~B7,Hsync,Vsync,DISP

【Note 2】 Humidity : 80%RHMax. (Ta≤40°C)

Maximum bulb temperature under 39°C (Ta>40°C) See to it that no dew will be condensed.

【Note 3】 Panel surface temperature prescribes.

(Reliability is examined at ambient temperature of 50°C.)

【Note 4】 Power consumption of one LED (Ta=25°C) (use 9 pieces LED)

Ambient temperature and the maximum input are fulfilling the following operating conditions.

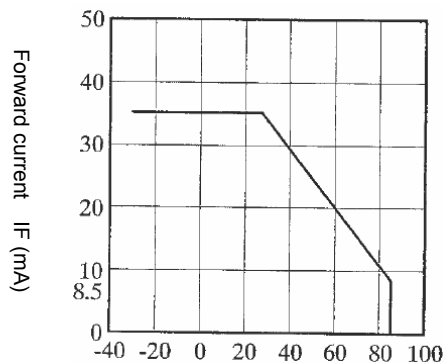

Ambient temperature and the maximum input

6. Electrical Characteristics

6-1. TFT LCD Panel Driving

Ta = 25°C

Item		Symbol	Min.	Typ.	Max.	Unit	Remarks
+3.3V power supply	DC voltage	VCC	+2.3	+3.3	+3.6	V	【Note 1】
	DC current	I _{CC}	-	0.5	2	mA	【Note 3】
+5V power supply	DC voltage	AVDD	+4.8	+5.0	+5.2	V	【Note 1】
	DC current	I _{AVDD}	-	8	16	mA	【Note 3】
Permissive input ripple voltage		V _{RFVCC}	-	-	100	mVp-p	VCC=+3.3V
		V _{RFAVDD}	-	-	100	mVp-p	AVDD=+5.0V
Input voltage (Low)		V _{IL}	-	-	0.2 V _{CC}	V	【Note 4】
Input voltage (High)		V _{IH}	0.8 V _{CC}	-	-	V	
Input current (Low)		I _{OL}	-	-	4.0	μA	V _I = 0V 【Note 4】
Input current (High)		I _{OH}	-	-	4.0	μA	V _I = 2.5V 【Note 4】

※ The rush current will flows when power supply is turned on, so please design the power supply circuit referring to 【Note 5】 .

(The rush current changes according to the condition of the supply voltage value, rising time and so on.)

[Note 1]

Sequences of supply voltage and signals

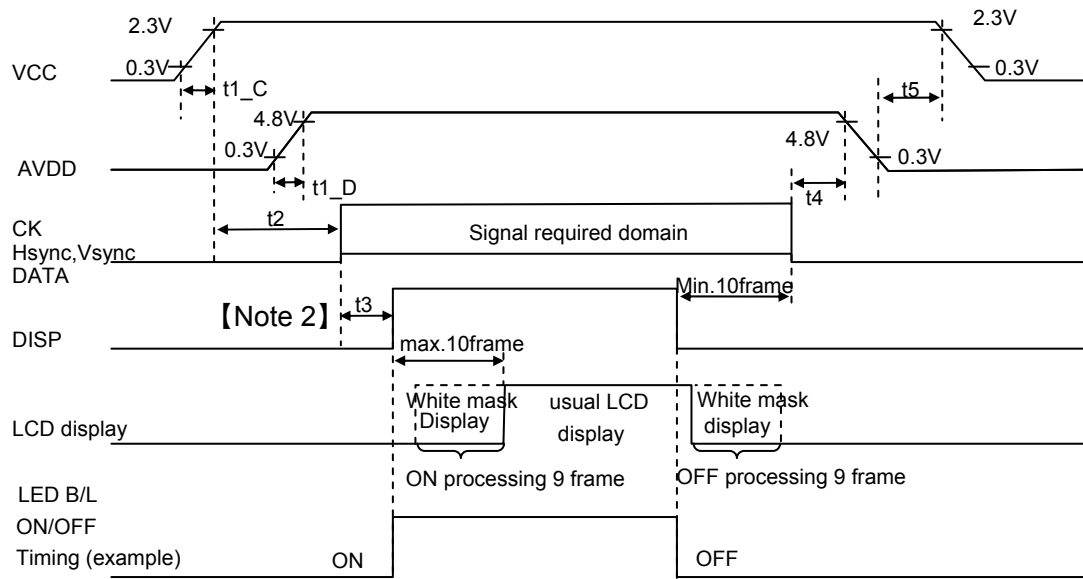

- ⊙ Please do not supply AVDD before VCC.
- ⊙ It discharges and boost up voltage for TFT module on the basis of a DISP-signal
It drives Max-10 flames (about 0.2seconds) from change of DISP-signals by reasons that
It takes time for 9 flames while each processing operation.
Therefore, the display start is delayed for 10 flames and Ten or more frames needs to be
voltage maintained at the time of a display end.
- ⊙ It is not problem to set up DISP=L ,AVDD=GND when VCC voltage is supplied
- ⊙ Please don't set various signals to Hi-Z when VCC-voltage is supplied
in reason that those signals are CMOS input.
- ⊙ Don't change DISP signal into the state of H level When AVDD voltage is in the state of GND.
- ⊙ The ON/OFF timing of LED Back Light is an example.

	MIN	TYP	MAX	unit	Remarks
t1_C	0	-	10	ms	
t1_D	0.5	-	10	ms	
t2	50	-	-	ms	
t3	0.5	-	-	ms	[Note 2]
t4	0	-	-	ms	
t5	0	-	-	ms	

Dip Conditions for supply voltage

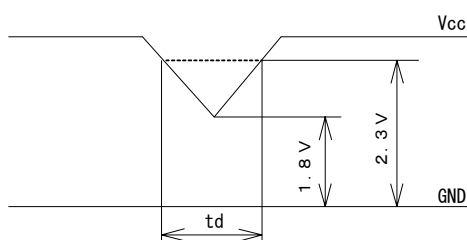

$t_d \leq 10ms$

【Note 2】 While “VSYNC” is “Low”, don't change “DISP” signal “Low” to “High”.

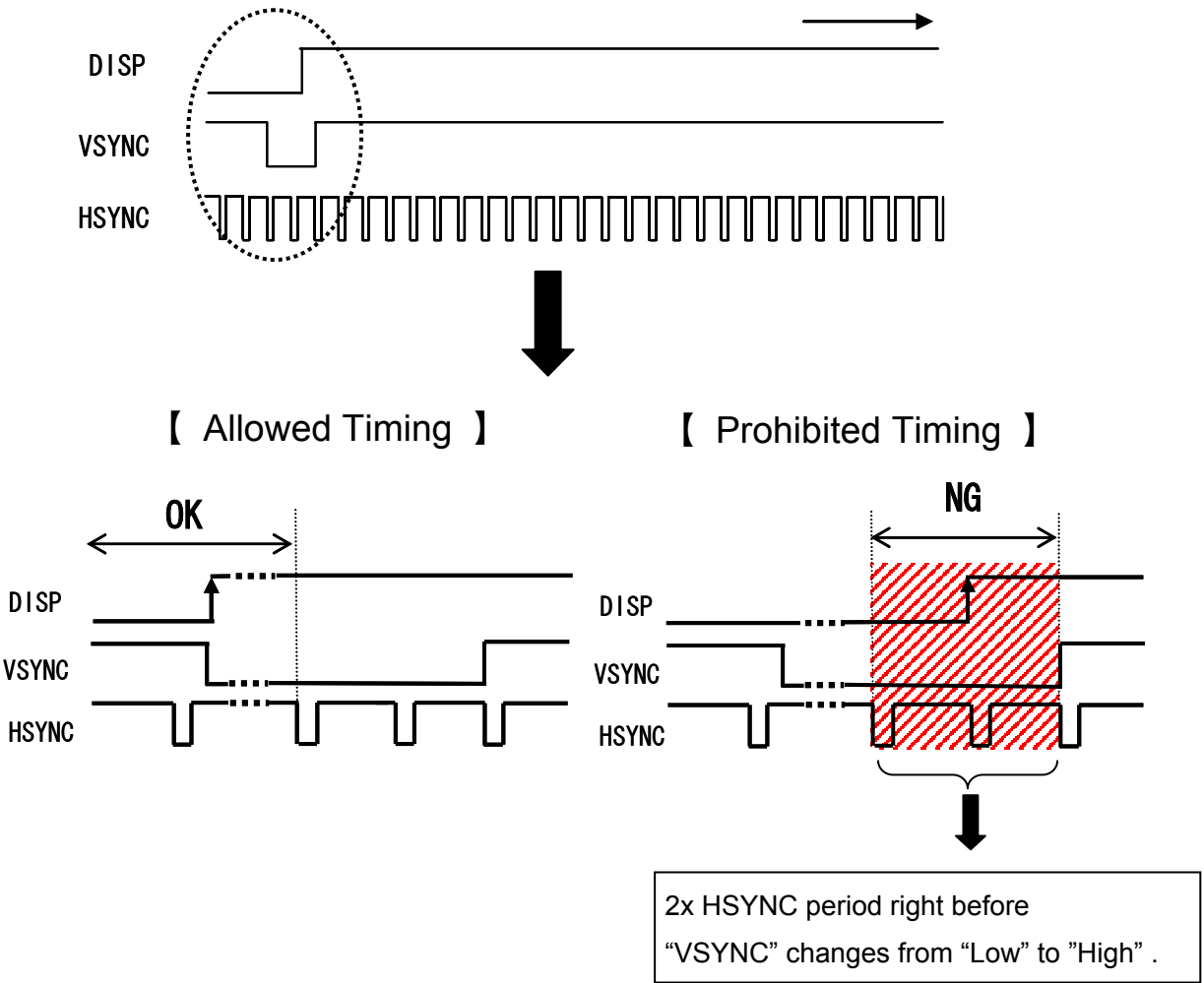

【Note 3】 Typical current situation: 256-gray-bar pattern VCC=3.3V AVDD=5.0V



【Note 4】 CK, R0~R7, G0~G7,B0~B7,Hsync,Vsync,DISP

【 Note 5 】

An example of rush current measurement

◎Measurement conditions

- Power supply voltage VCC : 3.3V AVDD : 5.0V
- Disp signal : OFF ⇒ ON
- Other input signals : GND
- Measurement system : refer to right Fig.
- rush current measurement timing : refer to following Fig.

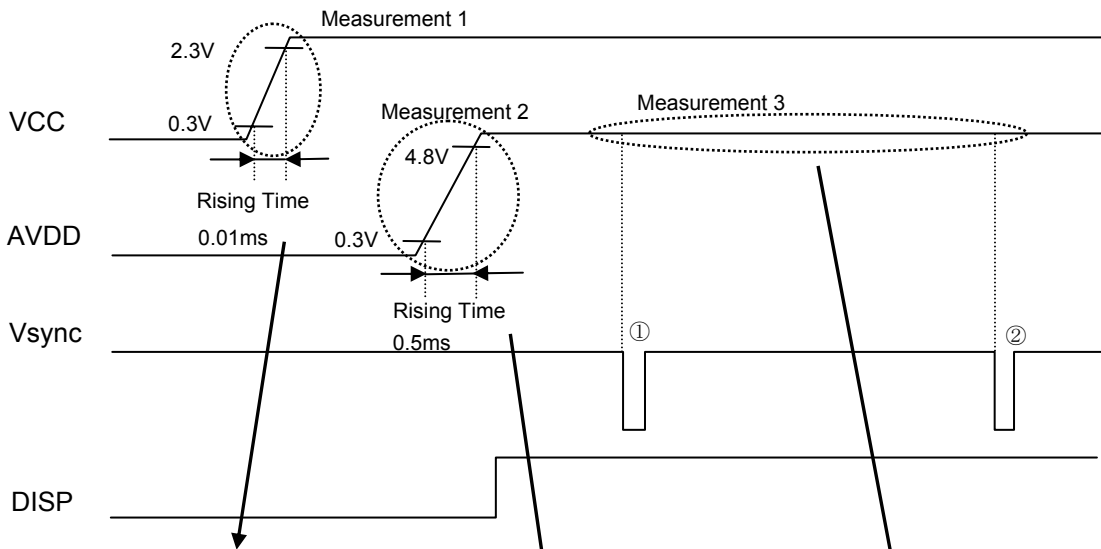
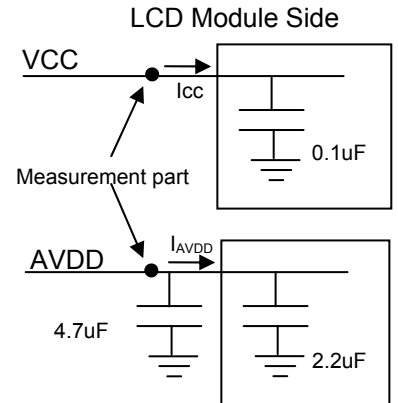

◎Measurement Example

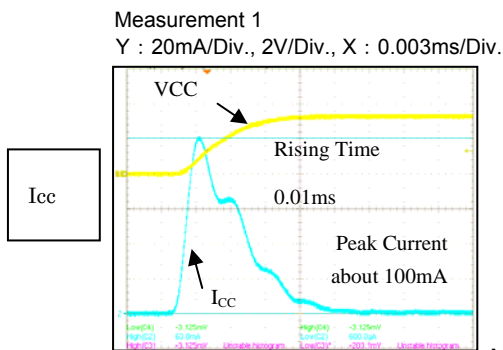

I_{cc}

Measurement 2 Y : 20mA/Div., 2V/Div., X : 0.08ms/Div. Measurement 3 Y : 50mA/Div., 5V/Div., X : 4ms/Div.

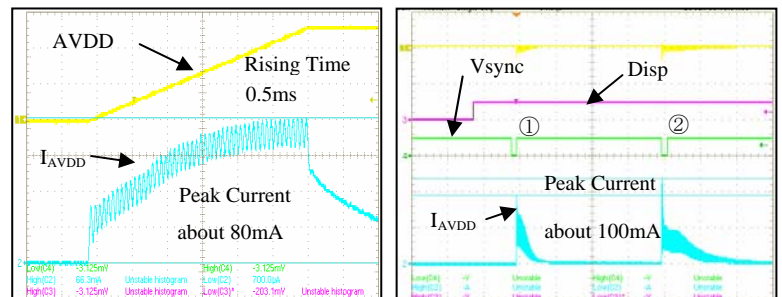

I_{AVDD}

These rush current won't flow stationary, these will flow at the timing shown in Measurement 3.

6-2. Back light driving







The back light system has nine LEDs

Parameter	Symbol	Min.	Typ.	Max.	Unit	Remark
Rated Voltage	V_{BL}	-	28.8	31.5	V	
Rated Current	I_L	-	20	-	mA	Ta=25°C

7. Timing characteristics of input signals

An input signal timing waveform is shown in Fig. 2.

7-1 Timing characteristics

Parameter		Symbol	Min.	Typ.	Max.	Unit	Remark
Clock 	Frequency	1/Tc	7.83	9.00	9.26	MHz	
	Duty ratio	Th/T	40	50	60	%	
	 Cycle	t _{CLK}	108	111	128	ns	
	 High Width	t _{CHW}	43	-	-	ns	
	 Low Width	t _{CLW}	43	-	-	ns	
 Vsync Setup Time	t _{VS}	25	-	-	ns		
 Hsync Setup Time	t _{HS}	25	-	-	ns		
DATA	Setup Time	t _{DS}	25	-	-	ns	
	Hold Time	t _{DH}	25	-	-	ns	
 Rising/Falling Time	t _{RF}	-	-	20	ns		
Horizontal synchronizing	Period	TH	-	525	-	Clock	
	Pulse width	THp	-	41	-	Clock	
	Horizontal period	THd	-	480	-	Clock	
	Back porch	THb	-	2	-	Clock	
	Front porch	THf	-	2	-	Clock	
Vertical synchronizing	Period	TV	-	286	-	Line	
	Pulse width	TVp	-	10	-	Line	
	Vertical period	TVd	-	272	-	Line	
	Back porch	TVb	-	2	-	Line	
	Front porch	TVf	-	2	-	Line	

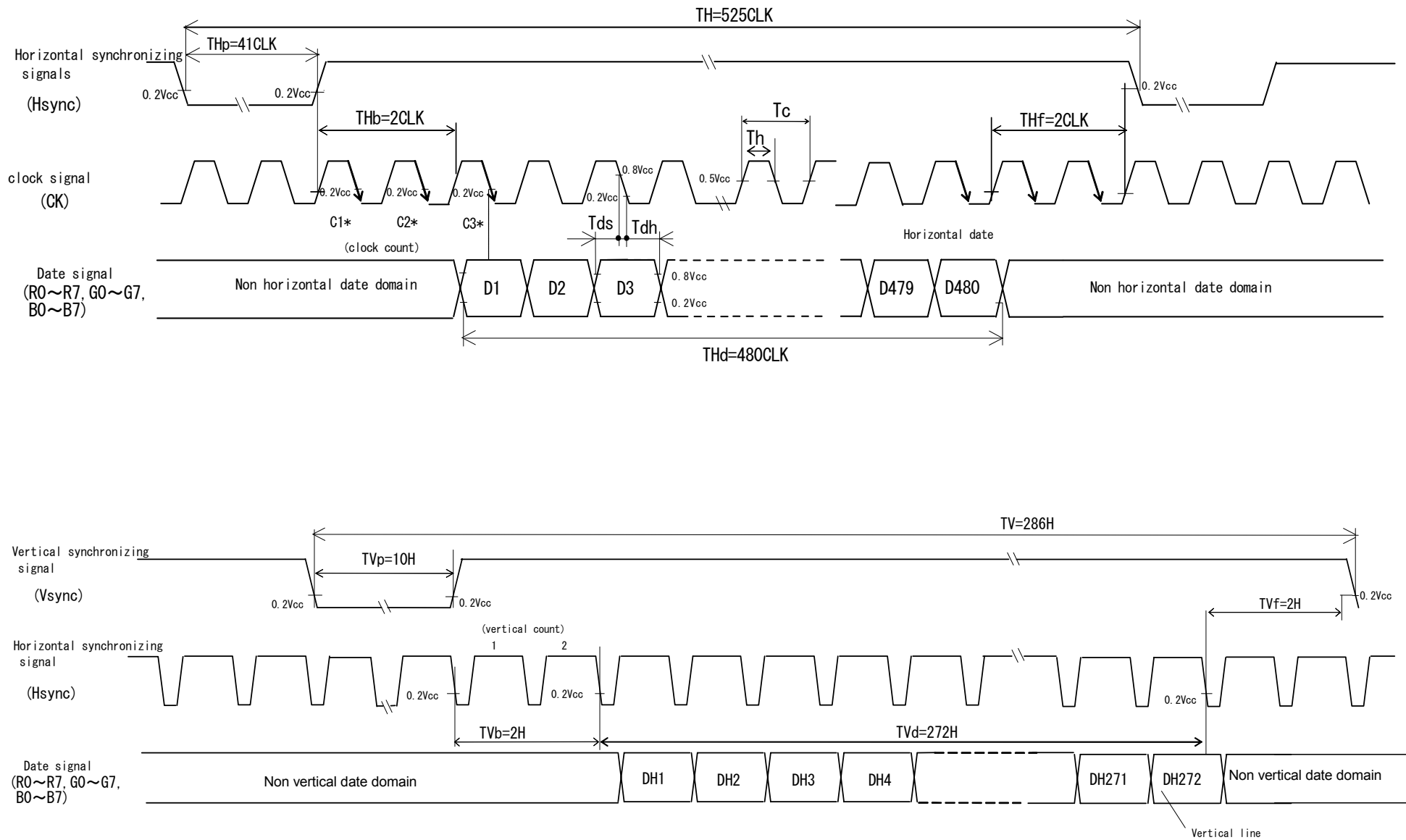
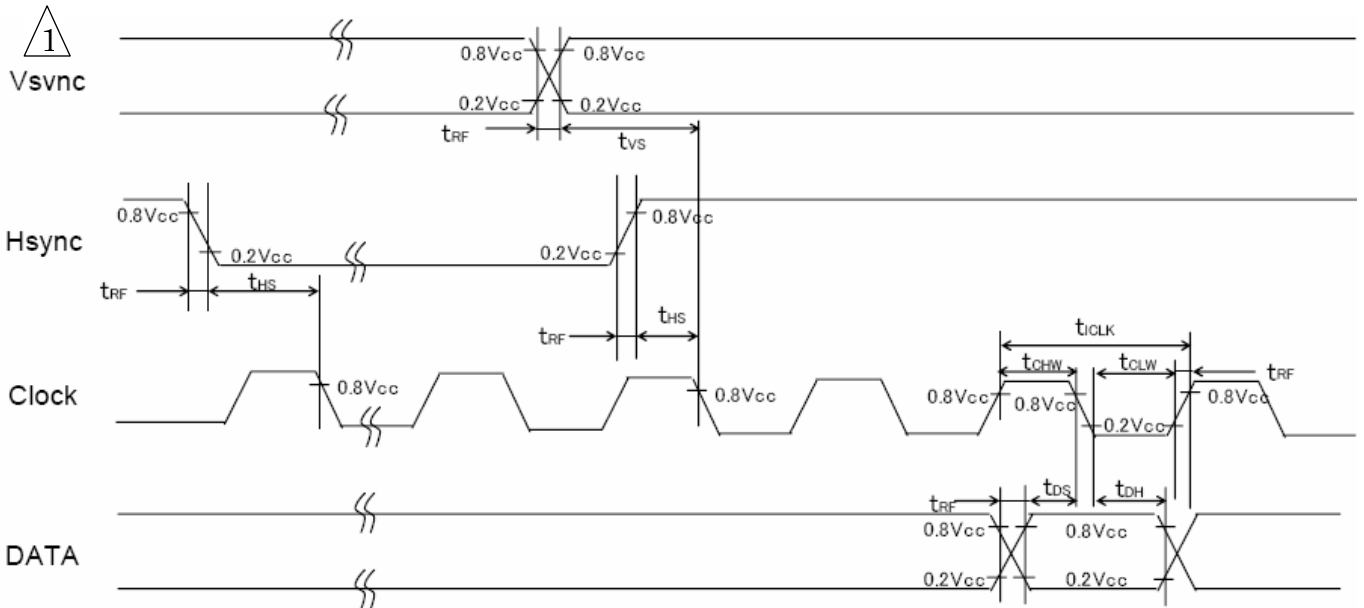
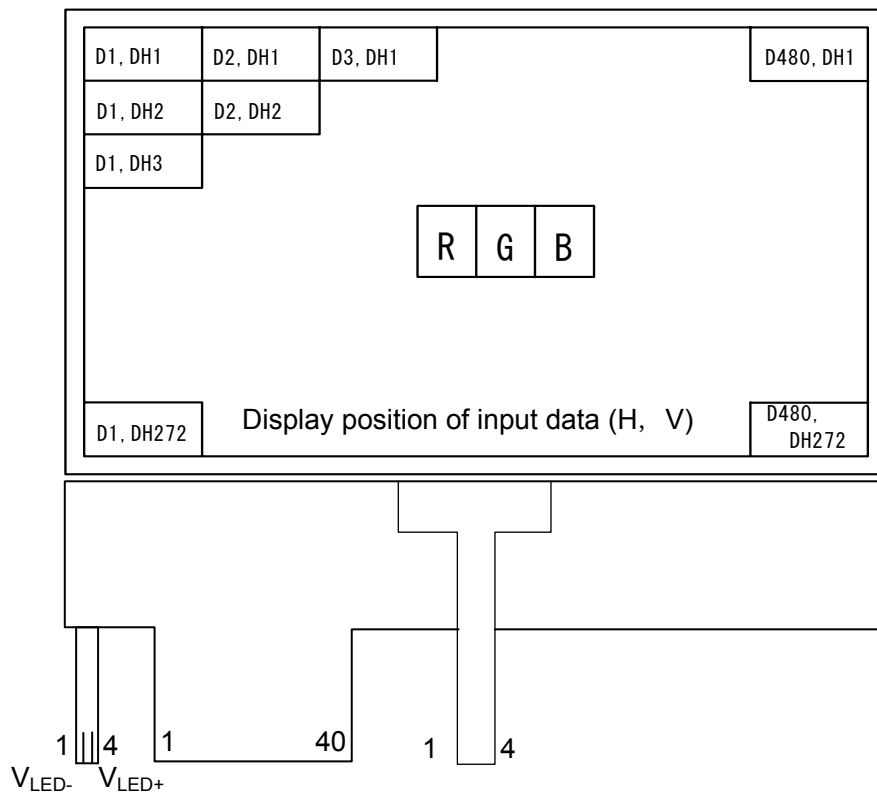

Fig.2 Input signal timing



- 【Note】**
- In case of using the slow frequency, the deterioration of display, flicker etc may occur.
 - The timing characteristics are basically fixed as above.

7-3 Input Data Signals and Display Position on the screen



Please refer to 4-3 about Touch Panel Pin arrangement.

Please refer to 4-1 about Pin arrangement.

Please refer to 4-2 about LED side Pin arrangement.

8. Input Signals, Basic Display Colors and Gray Scale of Each Color

Colors & Gray Scale	Date signal																												
	Gray Scale	R0	R1	R2	R3	R4	R5	R6	R7	G0	G1	G2	G3	G4	G5	G6	G7	B0	B1	B2	B3	B4	B5	B6	B7				
		LSB							MSB							LSB							MSB						
Basic Color	Black	—	0	0	0	0	0	0	0	0	0	0	0	0	0	0	0	0	0	0	0	0	0	0	0	0			
	Blue	—	0	0	0	0	0	0	0	0	0	0	0	0	0	0	0	0	1	1	1	1	1	1	1	1			
	Green	—	0	0	0	0	0	0	0	0	1	1	1	1	1	1	1	1	0	0	0	0	0	0	0	0			
	Cyan	—	0	0	0	0	0	0	0	0	1	1	1	1	1	1	1	1	1	1	1	1	1	1	1	1			
	Red	—	1	1	1	1	1	1	1	1	0	0	0	0	0	0	0	0	0	0	0	0	0	0	0	0			
	Magenta	—	1	1	1	1	1	1	1	1	0	0	0	0	0	0	0	0	1	1	1	1	1	1	1	1			
	Yellow	—	1	1	1	1	1	1	1	1	1	1	1	1	1	1	1	1	0	0	0	0	0	0	0	0			
	White	—	1	1	1	1	1	1	1	1	1	1	1	1	1	1	1	1	1	1	1	1	1	1	1	1			
Gray Scale of Red	Black	GS0	0	0	0	0	0	0	0	0	0	0	0	0	0	0	0	0	0	0	0	0	0	0	0	0			
	↑	GS1	1	0	0	0	0	0	0	0	0	0	0	0	0	0	0	0	0	0	0	0	0	0	0	0			
	Darker	GS2	0	1	0	0	0	0	0	0	0	0	0	0	0	0	0	0	0	0	0	0	0	0	0	0			
	↑	↓																											
	↓	↓																											
	Brighter	GS253	1	0	1	1	1	1	1	1	0	0	0	0	0	0	0	0	0	0	0	0	0	0	0	0			
	↓	GS254	0	1	1	1	1	1	1	1	0	0	0	0	0	0	0	0	0	0	0	0	0	0	0	0			
	Red	GS255	1	1	1	1	1	1	1	1	0	0	0	0	0	0	0	0	0	0	0	0	0	0	0	0			
Gray Scale of Green	Black	GS0	0	0	0	0	0	0	0	0	0	0	0	0	0	0	0	0	0	0	0	0	0	0	0	0			
	↑	GS1	0	0	0	0	0	0	0	0	1	0	0	0	0	0	0	0	0	0	0	0	0	0	0	0			
	Darker	GS2	0	0	0	0	0	0	0	0	0	1	0	0	0	0	0	0	0	0	0	0	0	0	0	0			
	↑	↓																											
	↓	↓																											
	Brighter	GS253	0	0	0	0	0	0	0	0	1	0	1	1	1	1	1	1	0	0	0	0	0	0	0	0			
	↓	GS254	0	0	0	0	0	0	0	0	0	1	1	1	1	1	1	1	0	0	0	0	0	0	0	0			
	Green	GS255	0	0	0	0	0	0	0	0	1	1	1	1	1	1	1	1	0	0	0	0	0	0	0	0			
Gray Scale of Blue	Black	GS0	0	0	0	0	0	0	0	0	0	0	0	0	0	0	0	0	0	0	0	0	0	0	0	0			
	↑	GS1	0	0	0	0	0	0	0	0	0	0	0	0	0	0	0	0	1	0	0	0	0	0	0	0			
	Darker	GS2	0	0	0	0	0	0	0	0	0	0	0	0	0	0	0	0	0	1	0	0	0	0	0	0			
	↑	↓																											
	↓	↓																											
	Brighter	GS253	0	0	0	0	0	0	0	0	0	0	0	0	0	0	0	0	1	0	1	1	1	1	1	1			
	↓	GS254	0	0	0	0	0	0	0	0	0	0	0	0	0	0	0	0	0	1	1	1	1	1	1	1			
	Blue	GS255	0	0	0	0	0	0	0	0	0	0	0	0	0	0	0	0	1	1	1	1	1	1	1	1			

0: Low level voltage, 1: High level voltage

Each basic color can be displayed in 256 gray scales from 8 bit data signals. According to the combination of 24 bit data signals, the 16-million-color display can be achieved on the screen.

9. Optical Characteristics

Module characteristics

Ta = 25°C, VCC = +3.3V, AVDD = 5.0V

Parameter	Symbol	Condition	Min.	Typ.	Max.	Unit	Remark
Viewing angle range	Horizontal	θ_{21}, θ_{22}	-	60	-	Deg.	【Note1,4】
	Vertical	θ_{11}	-	40	-	Deg.	
		θ_{12}	-	60	-	Deg.	
Contrast ratio	CR	Optimum viewing angle	100	300	-	-	【Note2,4】
Response Time	Rise	τ_r	-	30	45	ms	【Note3,4】
	Decay	τ_d	-	30	45	ms	
Chromaticity of White	x	$\theta=0^\circ$	0.26	0.31	0.36	-	【Note4】
	y		0.29	0.34	0.39	-	
Luminance of white	X_{L1}	$\theta=0^\circ$	400	500	-	cd/m ²	$I_{LED}=20mA$ 【Note4】
Uniformity	U	$\theta=0^\circ$	70	80	-	%	【Note5】

※ The optical characteristics measurements are operated under a stable luminescence($I_{LED}=20mA$) and a dark condition. (Refer to following figure)

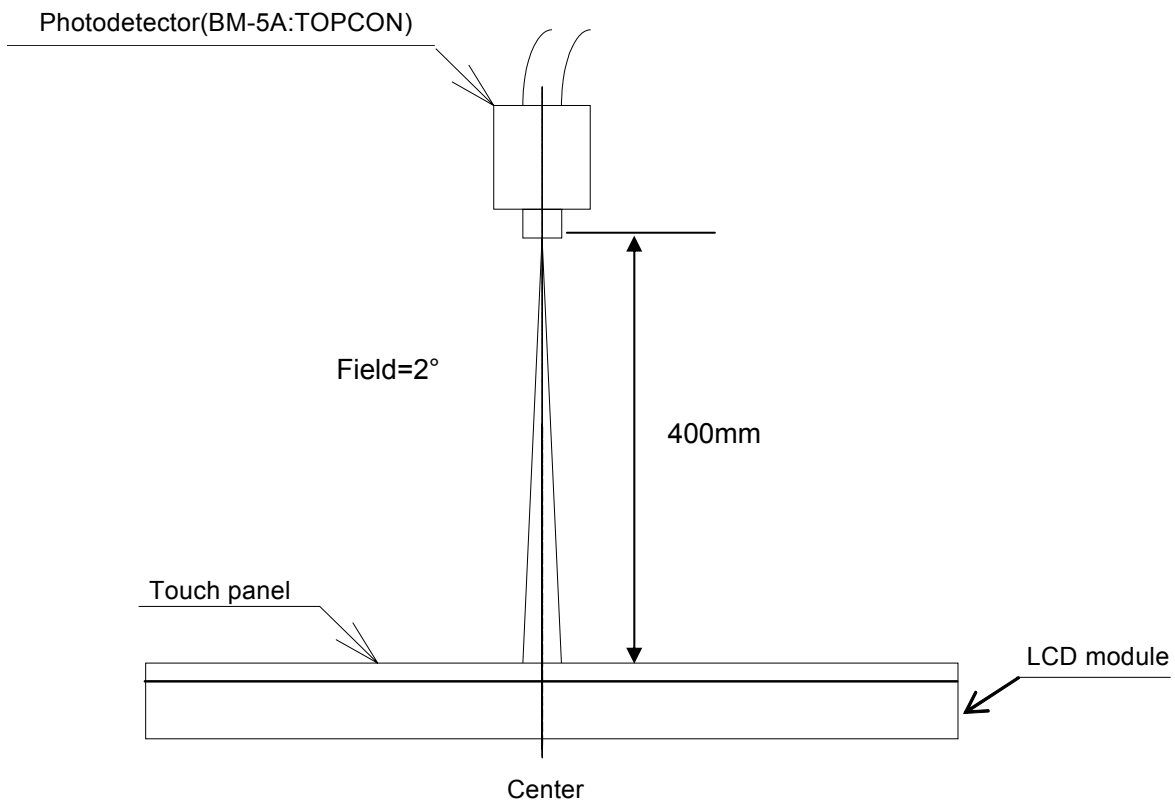

Measuring method (c) for optical characteristics

【 Note 1 】 Definitions of viewing angle range

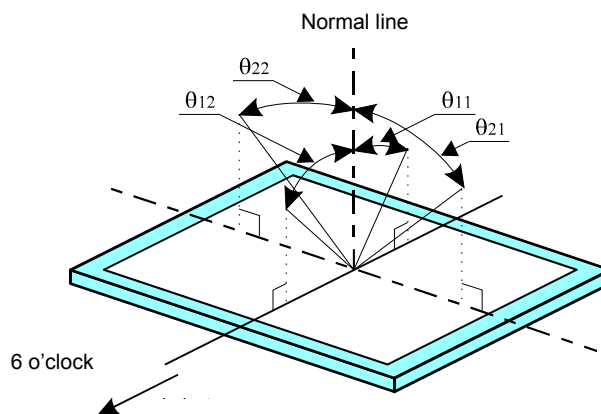

【 Note 2 】 Definition of contrast ratio

The contrast ratio is defined as the following

$$\text{Contrast ratio (CR)} = \frac{\text{Luminance (brightness) with all pixels white}}{\text{Luminance (brightness) with all pixels black}}$$

【 Note 3 】 Definition of response time

The response time is defined as the following figure and shall be measured by switching the input signal for "black" and "white"

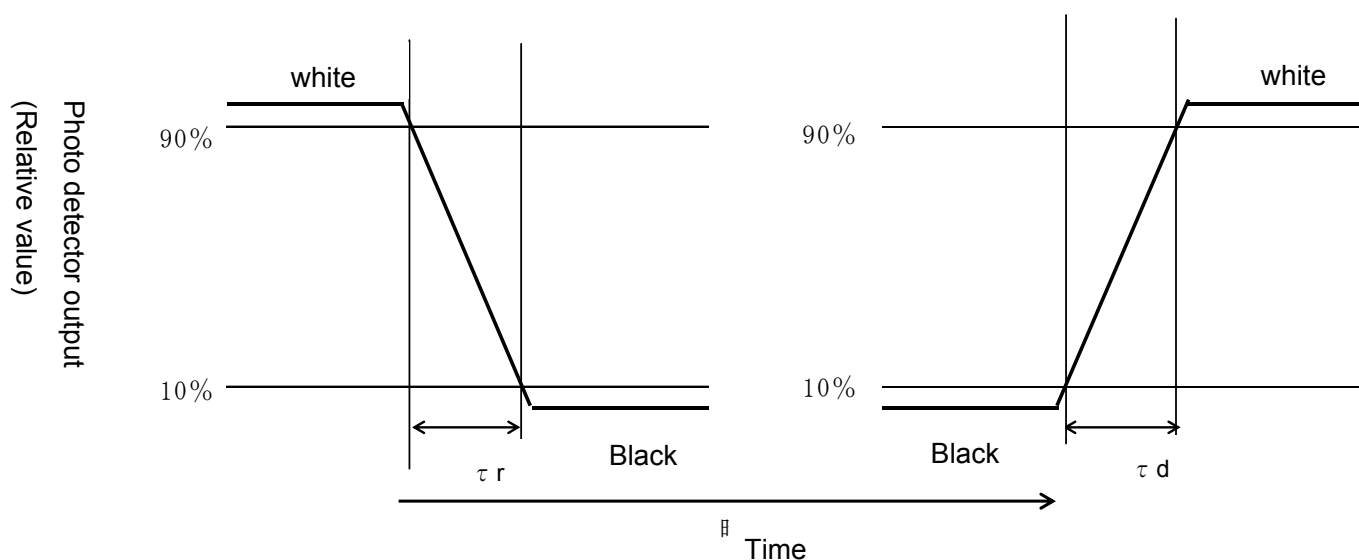

【 Note 4 】 This shall be measured at center of the screen.

【 Note 5 】 Definition of Uniformity.

$$\text{Uniformity} = \frac{\text{Minimum Brightness}}{\text{Maximum Brightness}} \times 100 (\%)$$

The brightness should be measured on the 9-point as shown in the following figure.

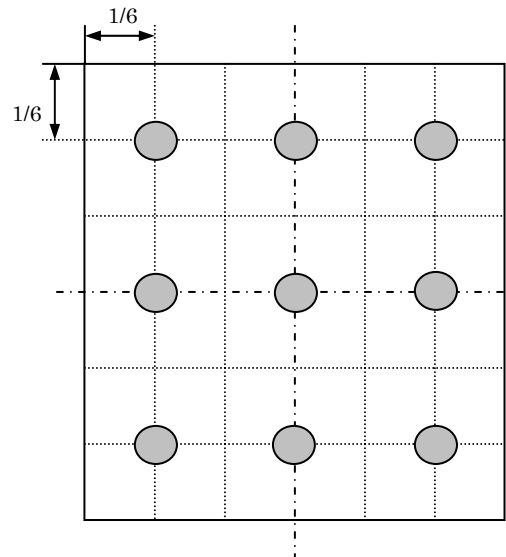

10. Touch panel characteristics

Parameter	Min.	Typ.	Max.	Unit	Remark
Input voltage	-	5.0	7.0	V	
Resistor between terminals (XL-XR)	200	463	900	Ω	Provisional specification
Resistor between terminals (YU-YD)	160	291	640	Ω	
Line linearity (X direction)	-	-	1.5	%	
Line linearity (Y direction)	-	-	1.5	%	
Insulation resistance	20	-	-	M Ω	at DC25V
Minimum tension for detecting	-	-	0.88	N	

11. Mechanical characteristics

11-1) FPC (for LCD panel) characteristics

- (1) Specific connector: FH12A-40S-0.5SH(55) (HIROSE)
- (2) Bending endurance of the bending slits portion
 No line of the FPC is broken for the bending test (Bending radius=0.6mm and angle=90°) in 30 cycles.

11-2) Design guidance for touch panel (T/P)

11-2-1) Example of housing design

- (1) If a consumer will put a palm on housing in normal usage, care should be taken as follows.
- (2) Keep the gap, for example 0.3 to 0.7mm, between bezel edge and T/P surface.
 The reason is to avoid the bezel edge from contacting T/P surface that may cause a "short" with bottom layer (See Fig.3)
- (3) Insertion a cushion material is recommended.
- (4) The cushion material should be limited just on the busbar insulation paste area.
 If it is over the transparent insulation paste area, a "short" may be occurred.
- (5) There is one where a resistance film is left in the T/P part of the end of the pole.
 Design to keep insulation from the perimeter to prevent from mis-operation and so on.

11-2-2) Mounting on display and housing bezel

- (1) In all cases, the T/P should be supported from the backside of the Plastic.
- (2) Do not to use an adhesive-tape to bond it on the front of T/P and hang it to the housing bezel.
- (3) Never expand the T/P top layer (PET-film) like a balloon by internal air pressure.
 The life of the T/P will be extremely short.
- (4) Top layer, PET, dimension is changing with environmental temperature and humidity.
 Avoid a stress from housing bezel to top layer, because it may cause "waving".
- (5) The input to the Touch panel sometimes distorts touch panel itself.

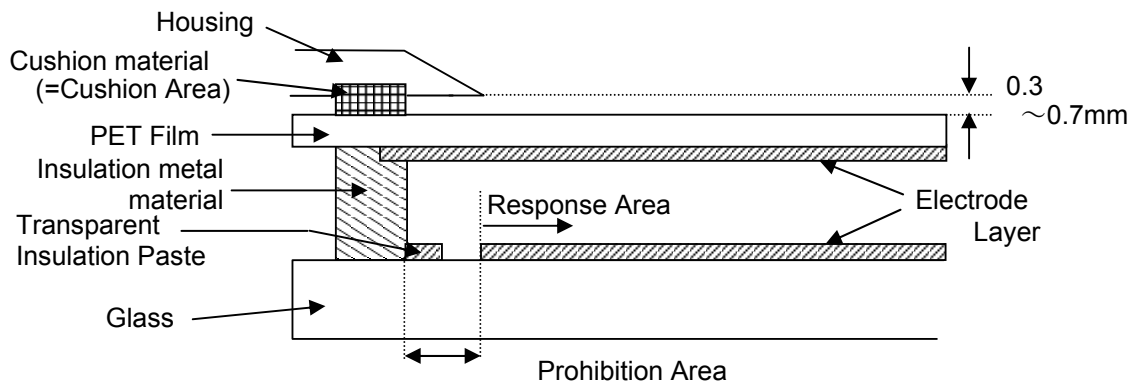

12. Handling of modules

12-1 Inserting the FPC into its connector and pulling it out.

- ① Be sure to turn off the power supply and the signals when inserting or disconnecting the cable.
- ② Please insert for too much stress not to join FPC in the case of insertion of FPC.

12-2 About handling of FPC

- ① The bending radius of the FPC should be more than 1.4mm, and it should be bent evenly.
- ② Do not dangle the LCD module by holding the FPC, or do not give any stress to it.

12-3 Mounting of the module

- ① The module should be held on to the plain surface. Do not give any warping or twisting stress to the module.
- ② Please consider that GND can ground a modular metal portion etc. so that static electricity is not charged to a module.

12-4 Cautions in assembly / Handling pre cautions.

As the polarizer can be easily scratched, be most careful in handling it.

① Work environments in assembly.

Working under the following environments is desirable:

- a) Implement more than 1MΩ conductive treatment (by placing a conductive mat or applying Conductive paint) on the floor or tiles.
- b) No dusts come in to the working room. Place an adhesive, anti-dust mat at the entrance of the room.
- c) Humidity of 50~70% and temperature of 15~27°C are desirable.
- d) All workers wear conductive shoes, conductive clothes, conductive fingerstalls and grounding belts without fail.
- e) Use a blower for electrostatic removal. Set it in a direction slightly tilt downward so that each Module can be well subjected to its wind. Set the blower at an optimum distance between the blower and the module.

② How to remove dust on the polarizer

- a) Blow out dust by the use of an N2 blower with antistatic measures taken. Use of an ionized air Gun is recommendable.
- b) When the panel surface is soiled, wipe it with soft cloth.

③ In the case of the module's metal part (shield case) is stained, wipe it with a piece of dry, soft cloth. If rather difficult, give a breath on the metal part to clean better.

④ If water dropped, etc. remains stuck on the polarizer for a long time, it is apt to get discolored or cause stains. Wipe it immediately.

⑤ As a glass substrate is used for the TFT-LCD panel, if it is dropped on the floor or hit by something hard, it may be broken or chipped off.

⑥ Since CMOS LSI is used in this module, take care of static electricity and take the human earth into consideration when handling.

12-5 Others

- ① Regarding storage of LCD modules, avoid storing them at direct sunlight-situation.

You are requested to store under the following conditions:

(Environmental conditions of temperature/humidity for storage)

(1) Temperature: 0~40°C

(2) Relative humidity : 95% or less

- As average values of environments (temperature and humidity) for storing, use the following control guidelines:

Summer season: 20~35°C, 85% or less Winter season: 5~15°C, 85% or less

- If stored under the conditions of 40°C and 95% RH, cumulative time of storage must be less than 240 hours.

- ① If stored at temperatures below the rated values, the inner liquid crystal may freeze, causing cell destruction. At temperatures exceeding the rated values for storage, the liquid crystal may become isotropic liquid, making it no longer possible to come back to its original state in some cases.
- ② If the LCD is broken, do not drink liquid crystal in the mouth. If the liquid crystal adheres to a hand or foot or to clothes, immediately cleanse it with soap.
- ③ If a water drop or dust adheres to the polarizer, it is apt to cause deterioration. Wipe it immediately.
- ④ Be sure to observe other caution items for ordinary electronic parts and components.

13. Delivery Form

13-1. Carton storage conditions

1) Carton piling-up: Max 8 rows

2) Environments

Temperature: 0~40°C

Humidity: 65% RH or less (at 40°C)

There should be no dew condensation even at a low temperature and high humidity.

3) Packing form: As shown in Figure 4.

※Cartons are weak against damp, and they are apt to be smashed easily due to the compressive pressure applied when piled up. The above environmental conditions of temperature and humidity are set in consideration of reasonable pile-up for storage.

13-2. Packing composition

Name	quantity	Note
Carton size	1	575×360×225 (mm)
Tray (The number of Module)	12	Material: Electrification prevention polypropylene 8 unit/tray: 80 unit/carton
Electrification prevention bag	2	Material: Electrification prevention polyethylene 680mm(length)×500mm(depth)×50μm(thin)

Carton weight (80 modules): Approx. 9.2 kg

14. Reliability test items

No.	Test item	Conditions
1	High temperature storage test	Ta = +85°C 240h
2	Low temperature storage test	Ta = -30°C 240h
3	High temperature & high humidity operation test	Ta = +40°C ; 95%RH 240h (No condensation)
4	High temperature operation test	Ta = +70°C 240h (The panel temp. must be less than 50°C)
5	Low temperature operation test	Ta = -10°C 240h
6	Vibration test (non- operating)	Frequency : 10~55Hz/Vibration width (one side) : 1.5mm Sweep time : 1minutes Test period : (2 hours for each direction of X,Y,Z)
7	Shock test	Direction: ±X, ±Y, ±Z, Time: Third for each direction. Impact value : 100G Action time 6ms
8	Thermal shock test	Ta=-25°C~80°C /10 cycles (30 min) (30min)
9	Electro static discharge test	±200V·200pF(0Ω) to Terminals(Contact) (1 time for each terminals) ±8kV · 150pF(330Ω) to Housing bezel or T/P(Contact) ±15kV · 150pF(330Ω) to Housing bezel or T/P(in Air)
10	Point activation test (Touch panel)	Hit it 1,000,000 times with a silicon rubber of R8 HS 60. Hitting force :2.4N Hitting speed : 3 times per second
11	Writing friction resistance test (Touch panel)	Slide Pen 100,000 times under following conditions: Pen: 0.8Rmm Placental stylus Load: 2.4N Speed: 3 strokes per second Stroke: 30mm Testing apparatus: shown in Fig (I)
12	FPC Bending Test	Bending 30 times by bending radius R0.6mm and angle=90°(LCD FPC, T/P FPC)

【Note】 Ta = Ambient temperature

【Check items】

(a)Test No.1~9

In the standard condition, there shall be no practical problems that may affect the display function.

(b)Test No.10~No.11

The measurements after the tests are satisfied Touch panel characteristics.

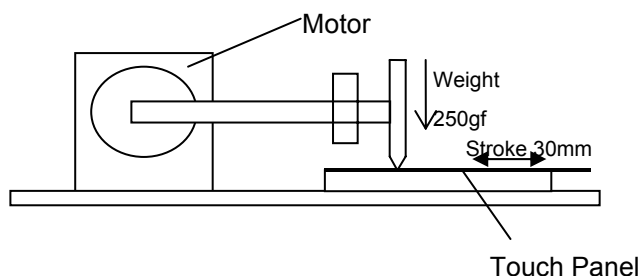

Fig.(I)

【Result Evaluation Criteria】

Under the display quality test conditions with normal operation state, these shall be no change which may affect practical display function.

15. Display Grade

The standard regarding the grade of color LCD displaying modules should be based on the delivery inspection standard.

16. Lot No. marking

The lot No. will be indicated on individual labels. The location is as shown

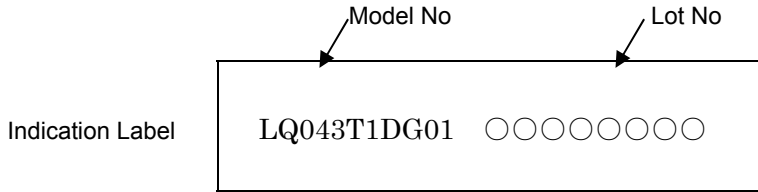

17. LCD module packing carton

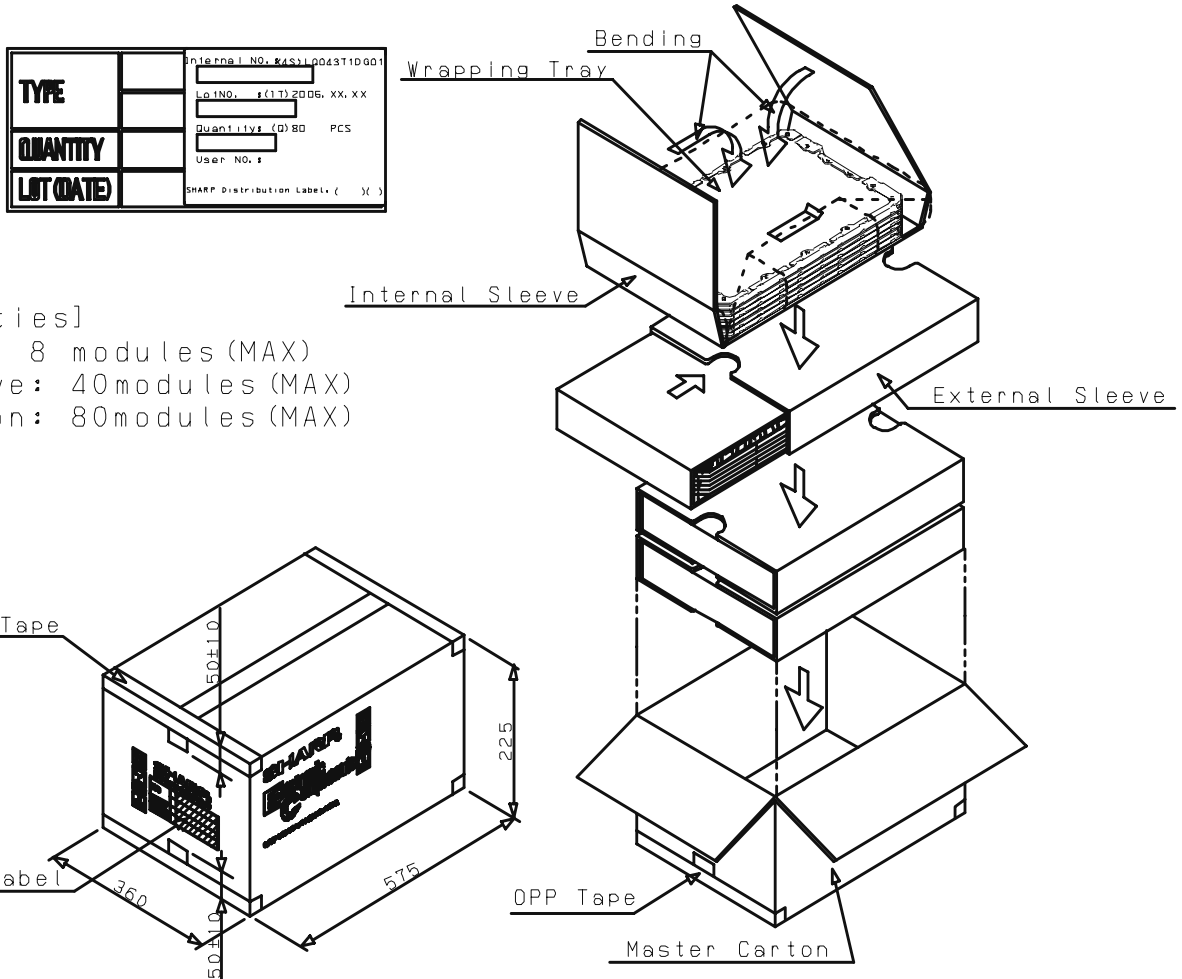

18. Others

- 1 Disassembling the module can cause permanent damage and you should be strictly avoided.
- 2 Please be careful that you don't keep the screen displayed fixed pattern image for a long time, since retention may occur.
- 3 If you pressed down a liquid crystal display screen with your finger and so on, the alignment disorder of liquid crystal will occur. And then it will become display fault.
Therefore, be careful not to touch the screen directly, and to consider not stressing to it.
- 4 If any problem arises regarding the items mentioned in this specification sheet or otherwise, it should be discussed and settled mutually in a good faith for remedy and/or improvement.

19. Outline dimension

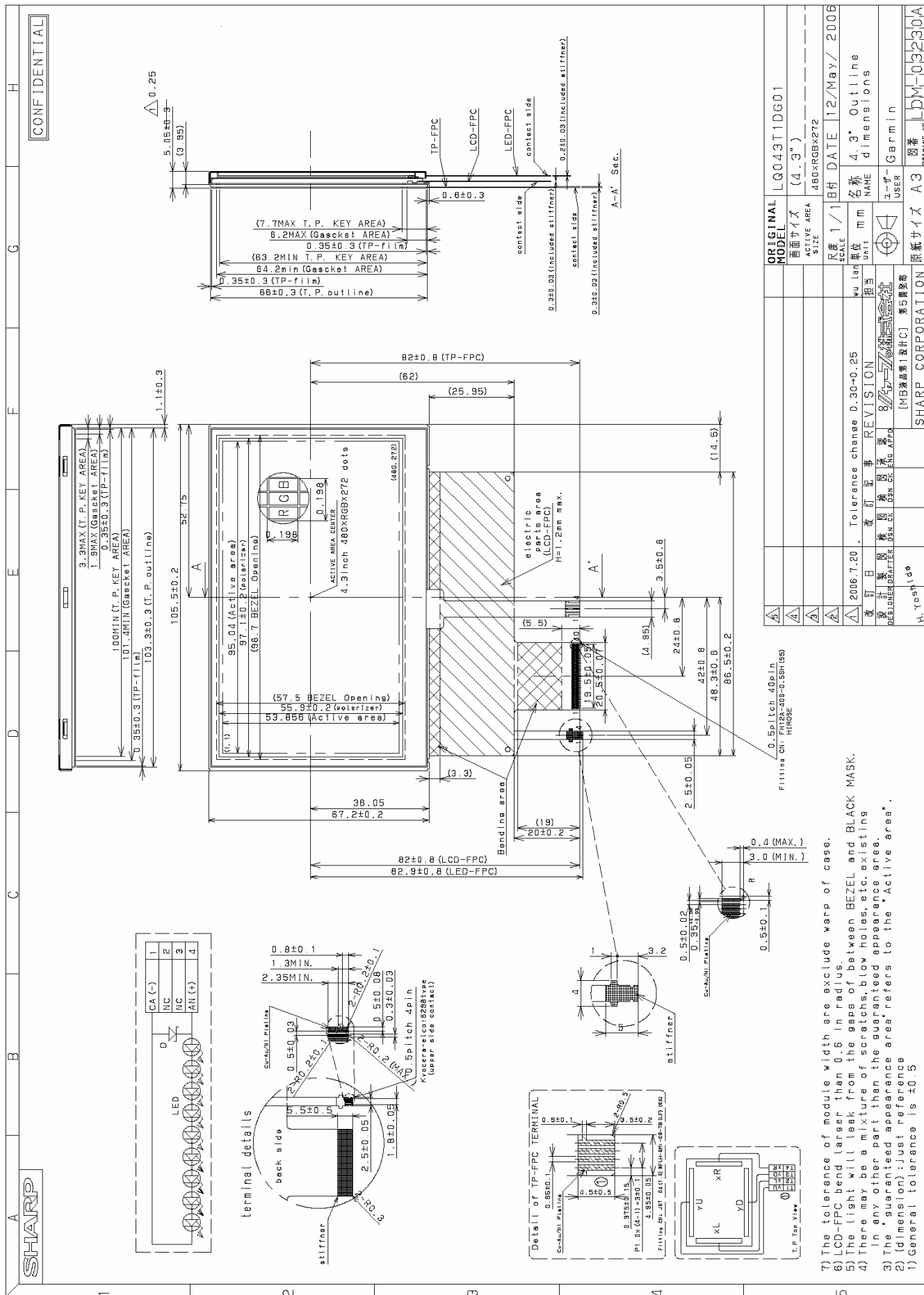

Fig.1

- 7) The tolerance of module width are exclude warp of case.
- 8) LCD-FPC bend (larger than 0.6 in radius).
- 9) The light will leak from the gaps of between BEZEL and BLACK MASK.
- 4) There may be a mixture of scratches, blow holes, etc. existing in any other part than the guaranteed appearance area.
- 3) The "guaranteed appearance area" refers to the "Active area".
- 2) (Dimension): Just reference
- 1) General tolerance is ±0.5