

PREPARED BY : DATE	SHARP MOBILE LIQUID CRYSTAL DISPLAY GROUP SHARP CORPORATION SPECIFICATION	SPEC No. LD-22706A
APPROVED BY : DATE		FILE No. LD-22706A
		ISSUE : 28-Jul-10
		PAGE : 21pages
		APPLICABLE GROUP MOBILE LIQUID CRYSTAL DISPLAY GROUP

REVISION :

DEVICE SPECIFICATION FOR
TFT-LCD Module
MODEL No.
LQ070Y3LW01

These parts have corresponded with the RoHS

CUSTOMER'S APPROVAL
BY _____

BY *K. Shiono*
K.Shiono
GENERAL MANAGER
ENGINEERING DEPARTMENT I
LIQUID CRYSTAL DISPLAY DIVISION III
LIQUID CRYSTAL DISPLAY GROUP
SHARP CORPORATION

No.		page
1	Application	1
2	Overview	2
3	Mechanical Specifications	2
4	Input Terminals	3
5	Absolute Maximum Ratings	9
6	Electrical Characteristics	10
7	Timing characteristics of input signals	12
8	Input Signals, Basic Display Colors and Gray Scale of Each Color ..	13
9	Optical Characteristics	14
10	Handling Precautions	16
11	Packing form	17
12	Reliability test items	17
13	Others	18
14	Storage conditions	19
Fig.1	Outline dimensions	20
Fig.3	Packing form	21

1. Application

This specification sheet applies to the color TFT-LCD module LQ070Y3LW01.

This specification sheet is the proprietary product of SHARP CORPORATION (SHARP) and include materials protected under copyright of SHARP. Do not reproduce or cause any third party to reproduce them in any form or by any means, electronic or mechanical, for any purpose, in whole or in part, without the express written permission of SHARP.

The device listed in this specification sheet was designed and manufactured for use in general electronic equipment.

In case of using the device for applications such as control and safety equipment for transportation (controls of aircraft, trains, automobiles, etc.), rescue and security equipment and various safety related equipment which require higher reliability and safety, take into consideration that appropriate measures such as fail-safe functions and redundant system design should be taken.

Do not use the device for equipment that requires an extreme level of reliability, such as aerospace applications, telecommunication equipment (trunk lines), nuclear power control equipment and medical or other equipment for life support.

SHARP assumes no responsibility for any damage resulting from the use of the device which does not comply with the instructions and the precautions specified in this specification sheet .

Contact and consult with a SHARP sales representative for any questions about this device.

2. Overview

This module is a color active matrix LCD module incorporating amorphous silicon TFT (Thin Film Transistor). It is composed of a color TFT-LCD panel, driver ICs, control circuit, power supply circuit and a White-LED Backlight unit. Graphics and texts can be displayed on a 800 × 480 × RGB dots panel with about 16 million colors by using LVDS (Low Voltage Differential Signaling) and supplying +3.3V DC supply voltage for TFT-LCD panel driving and supply voltage for backlight.

(Note: Backlight-driving DC/DC converter and the wire harness are not built in this module.)

- Fine images with stripe aligned 384,000 pixels on 7.0 inch diagonal screen.
- Color display capability of 16,194,277 colors with 24 bit data signal (6bit+2bit FRC for each RGB).
- Adapting a wide viewing angle technology.
- High contrast, thanks to active matrix drive system.
- Light and slim compact module achieved by (COG assemble technology.)
- These LCD modules have corresponded with the RoHS directive.

3. Mechanical specifications

Parameter	technical literatures	Unit
Display size	18 (7inch) Diagonal	cm
Active area	152.4 (H) × 91.4 (V)	mm
Pixel format	800 (H) × 480 (V) (1 pixel = R + G + B dot)	pixel
Aspect ratio	5 : 3	
Pixel pitch	0.1905 (H) × 0.1905 (V)	mm
Pixel configuration	R, G, B horizontal stripe	
Display mode	Normally black	
Unit outline dimensions	170.0 (W) × 110.0 (H) × 9.0 (D)	mm
Mass	175 (Typ.)	g
Surface treatment	Anti-glare and hard-coating 3H	

Outline dimensions are shown in Fig.1.

4. Input Terminals

4-1. TFT-LCD panel driving

CN1 (LVDS signals and +3.3V power supply)

Using connector : DF14H-20P-1.25H(56) (Hirose Electric Co., Ltd.)

Corresponding connector : DF14-20S-1.25C(conector) (Hirose Electric Co., Ltd.)

: DF14-2628SCF(terminal) (Hirose Electric Co., Ltd.)

Using LVDS receiver : Building into cotroll IC

Corresponding LVDS transmitter : THC63LVDM83R(Thine electronics) or Compatible product

CN1

Pin	Symbol	Function	Remark
1	VCC	+3.3V Power supply	
2	VCC	+3.3V Power supply	
3	GND	GND	
4	GND	GND	
5	RXIN0-	LVDS receiver signal CH0 (-)	LVDS
6	RXIN0+	LVDS receiver signal CH0 (+)	LVDS
7	GND	GND	
8	RXIN1-	LVDS receiver signal CH1 (-)	LVDS
9	RXIN1+	LVDS receiver signal CH1 (+)	LVDS
10	GND	GND	
11	RXIN2-	LVDS receiver signal CH2 (-)	LVDS
12	RXIN2+	LVDS receiver signal CH2 (+)	LVDS
13	GND	GND	
14	RXCKIN-	LVDS receiver signal CK (-)	LVDS
15	RXCKIN+	LVDS receiver signal CK (+)	LVDS
16	GND	GND	
17	RXIN3-	LVDS receiver signal CH3 (-)	LVDS
18	RXIN3+	LVDS receiver signal CH3 (+)	LVDS
19	GND	GND	
20	SELLVDS	LVDS SET	【*1】

【Note】To obtain the proper relation between LVDS signals and actual digital data signals, the digital signals should be inputted into the transmitter as described in the next section.

【*1】 SELLVDS is shown in 4-2.

4-2. Data Mapping

1) 8 bit input

【*1】 pin assignment with SELLVDS pin (THC63LVDM83R(Thine electronics) or Compatible product)

Transmitter		20Pin SELLVDS	
Pin No	Data	= H(3.3V)	= L(GND) or Open
51	TA0	R0 (LSB)	R2
52	TA1	R1	R3
54	TA2	R2	R4
55	TA3	R3	R5
56	TA4	R4	R6
3	TA5	R5	R7 (MSB)
4	TA6	G0 (LSB)	G2
6	TB0	G1	G3
7	TB1	G2	G4
11	TB2	G3	G5
12	TB3	G4	G6
14	TB4	G5	G7 (MSB)
15	TB5	B0 (LSB)	B2
19	TB6	B1	B3
20	TC0	B2	B4
22	TC1	B3	B5
23	TC2	B4	B6
24	TC3	B5	B7 (MSB)
27	TC4	(NA)	(NA)
28	TC5	(NA)	(NA)
30	TC6	DE	DE
50	TD0	R6	R0 (LSB)
2	TD1	R7 (MSB)	R1
8	TD2	G6	G0 (LSB)
10	TD3	G7 (MSB)	G1
16	TD4	B6	B0 (LSB)
18	TD5	B7 (MSB)	B1
25	TD6	(NA)	(NA)

< SELLVDS = H(3.3V) >

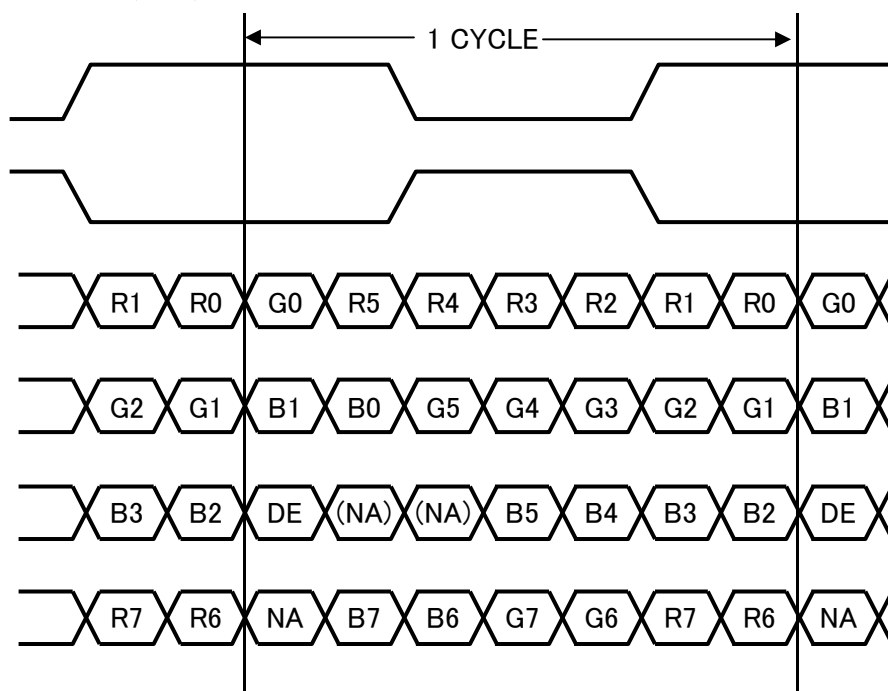

< SELLVDS = L(GND) or Open >

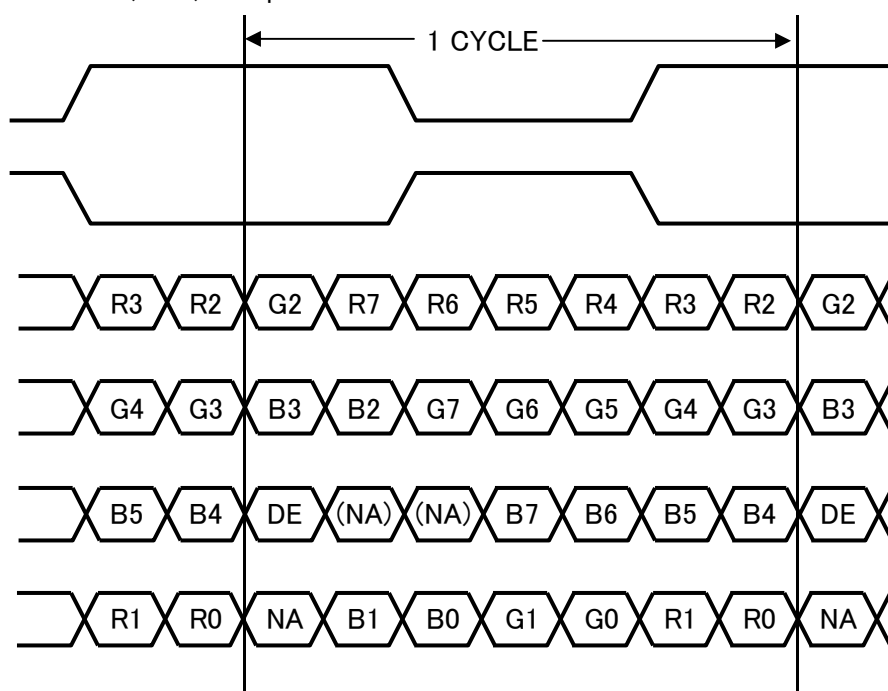

DE: DATA ENABLE

NA: Not Available

1) 6bit input

【*1】 pin assignment with SELLVDS (THC63LVDM83R(Thine electronics) or Compatible product)

Transmitter		20Pin SELLVDS	
Pin No	Data	= H(3.3V)	= L(GND) or Open
51	TA0	-	R0 (LSB)
52	TA1	-	R1
54	TA2	-	R2
55	TA3	-	R3
56	TA4	-	R4
3	TA5	-	R5 (MSB)
4	TA6	-	G0 (LSB)
6	TB0	-	G1
7	TB1	-	G2
11	TB2	-	G3
12	TB3	-	G4
14	TB4	-	G5 (MSB)
15	TB5	-	B0 (LSB)
19	TB6	-	B1
20	TC0	-	B2
22	TC1	-	B3
23	TC2	-	B4
24	TC3	-	B5 (MSB)
27	TC4	-	(NA)
28	TC5	-	(NA)
30	TC6	-	DE
50	TD0	-	GND
2	TD1	-	GND
8	TD2	-	GND
10	TD3	-	GND
16	TD4	-	GND
18	TD5	-	GND
25	TD6	-	(NA)

< SELLVDS = L(GND) or Open >

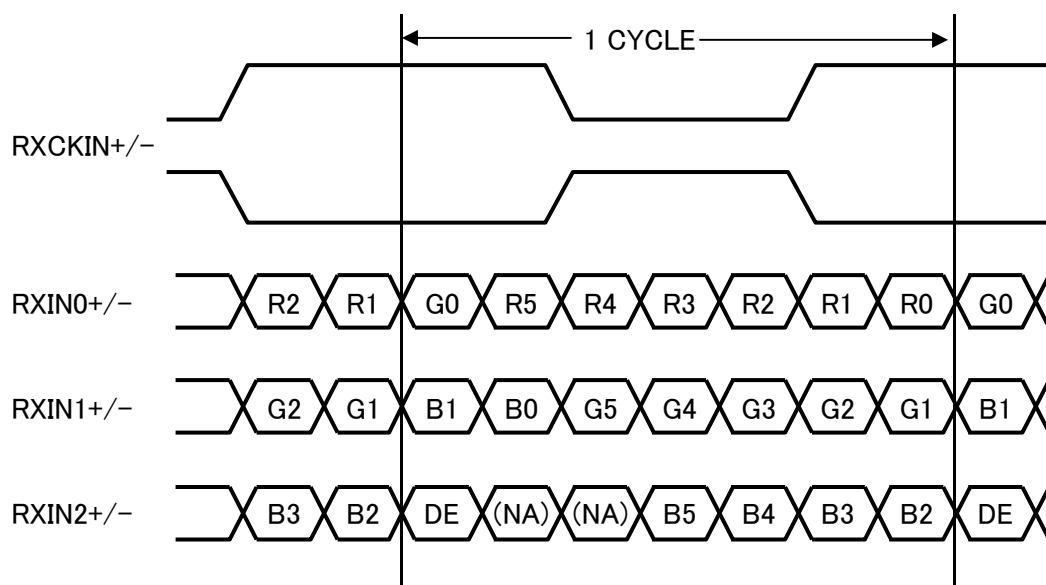

DE: DATA ENABLE

NA: Not Available

4-3. LED backlight

LED backlight connector

CN2 Using connector : 50156806 (Molex)

 Corresponding connector : 5013300600 (Molex)

Connector No.	Pin No.	symbol	function
CN2	1	NC	-
	2	+ch2	Power supply for LED (Ch2 High voltage side)
	3	+ch1	Power supply for LED (Ch1 High voltage side)
	4	-ch1	Power supply for LED (Ch1 Low voltage side)
	5	-ch2	Power supply for LED (Ch2 Low voltage side)
	6	NC	-

4-4. Interface block diagram

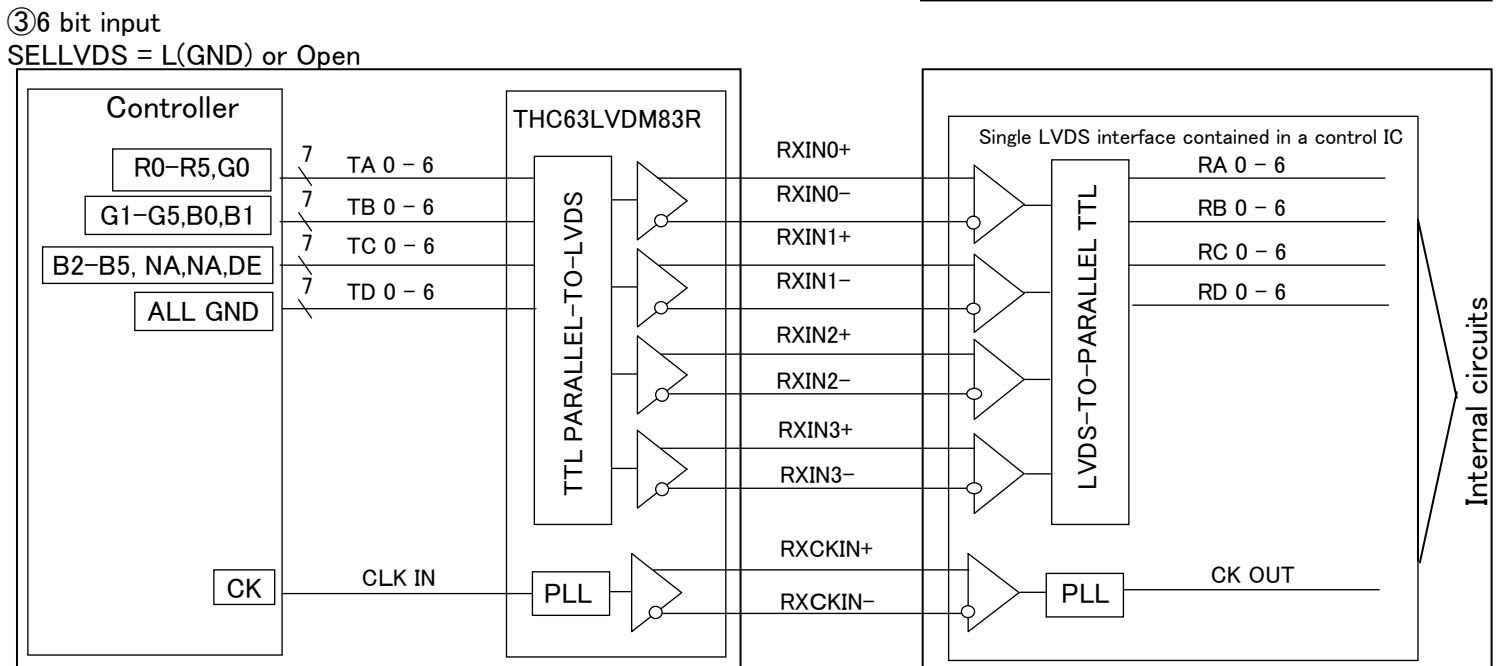
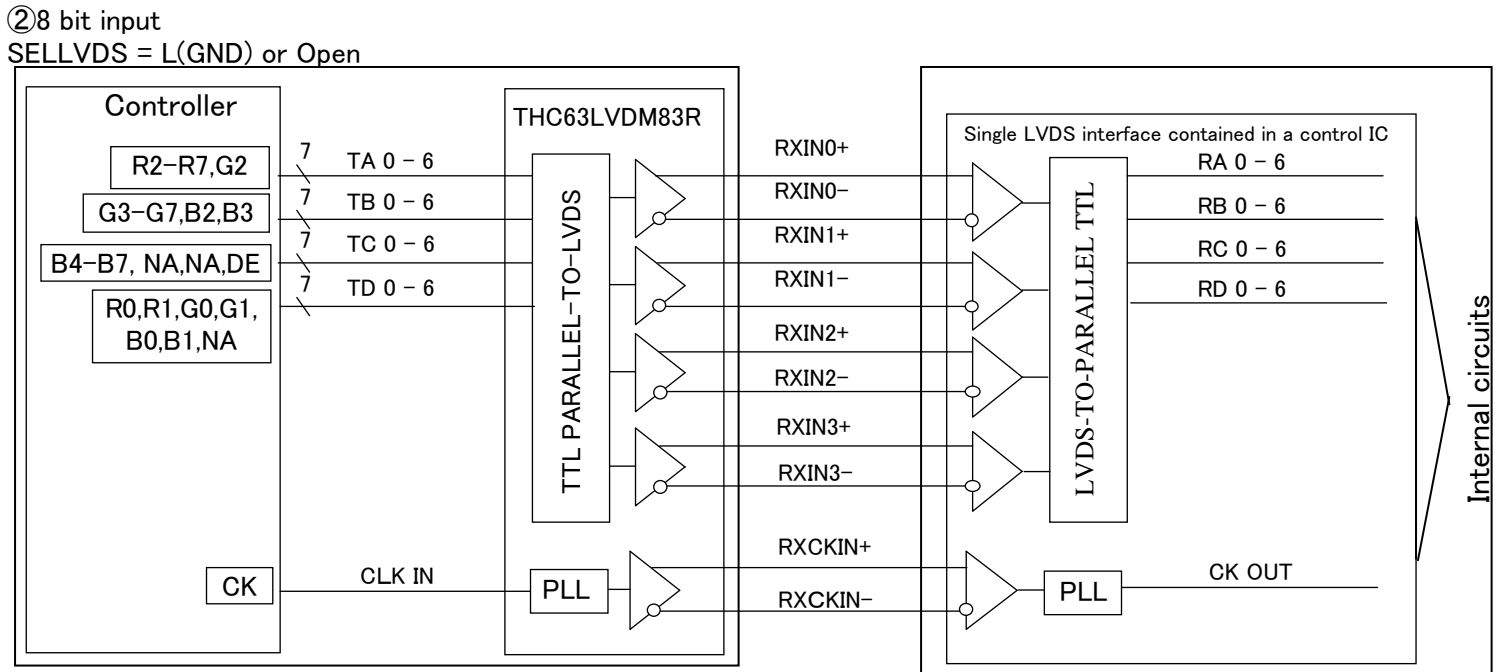
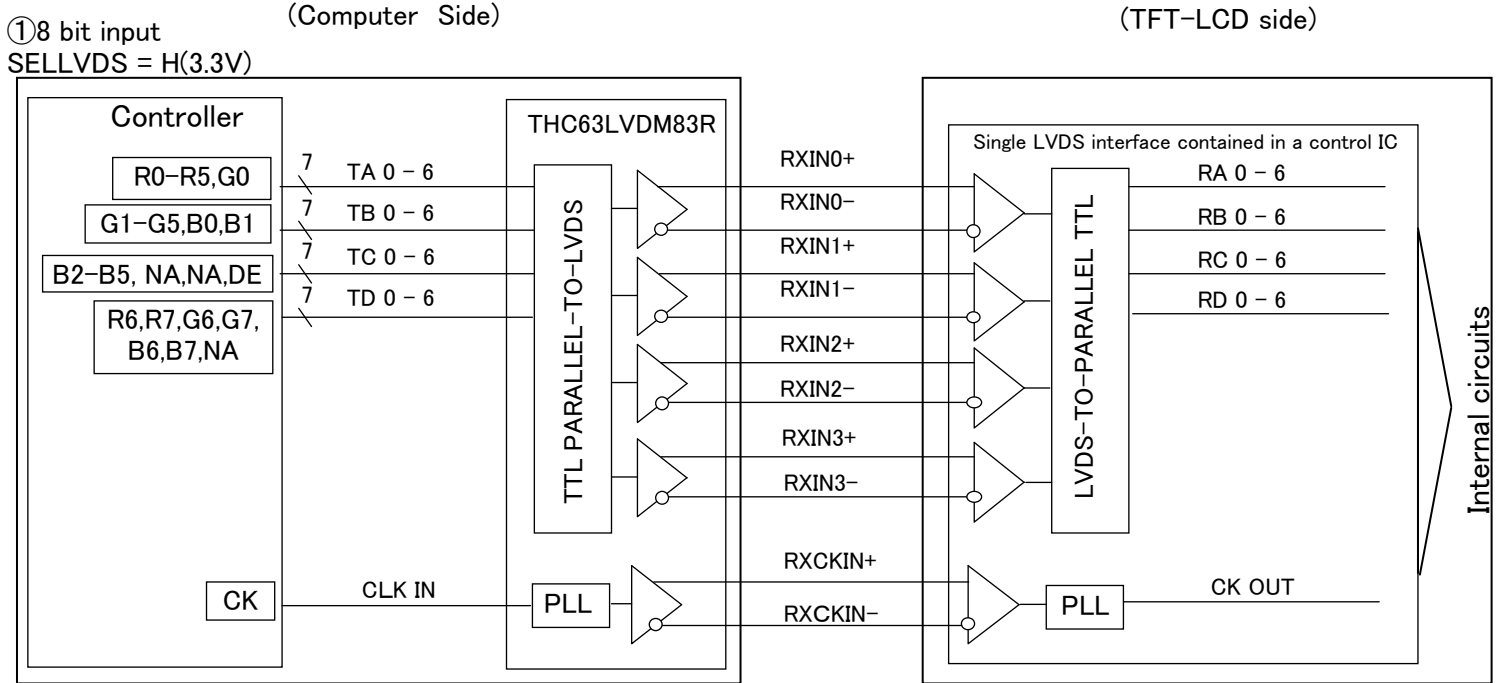

5. Absolute Maximum Ratings

Parameter	Symbol	Condition	Pin	Ratings	Unit	Remark
Supply voltage	V _{CC}	T _a =25°C	VCC	-0.3 ~ +4.0	V	【*1,2】
LVDS Input voltage	V _{IL}	T _a =25°C	RXINi-/+ RXCKIN-/+	-0.3~V _{CC} +0.3	V	i=0,1,2,3
Storage temperature	T _{STG}	—	—	-25 ~ +70	°C	【*1,3】
Operating temperature	T _{OPP}	—	—	-10 ~ +65	°C	

【*1】 Humidity: 95%RH Max.(T_a ≤ 40°C) Note static electricity.

Maximum wet-bulb temperature at 39°C or less. (T_a > 40°C) No condensation.

It may stop acting normally, when it operates it for a long time with having condensed.

It may cause the deterioration of display quality like non-uniformity in case of storage or usage condition in more than 65°C,

It may also cause the deterioration of display quality in case of the continuous usage under the high temperature and high humidity environment.

【*2】 The VCC power supply capacity must use the one of 2A or more.

【*3】 The minimum value of T_{opp} is defined as the ambient temperature.

The maximum value of T_{opp} is defined as the temperature of panel surface where is the highest.

6. Electrical Characteristics

6-1. TFT-LCD panel driving

 $T_a = +25^\circ\text{C}$

Parameter	Symbol	Min.	Typ.	Max.	Unit	Remark
Supply voltage	V_{CC}	3.0	3.3	3.6	V	【*1】
Current dissipation	I_{CC}	—	190	255	mA	【*2】
Input voltage range	V_L	0	—	2.4	V	LVDS signals
Permissible input ripple voltage	V_{RP}	—	—	100	mV _{p-p}	$V_{CC}=3.3\text{V}$
Differential input Threshold voltage	High	V_{TH}	—	$V_{CM} + 100$	mV	$V_{CM} = +1.2\text{V}$ 【*3】
	Low	V_{TL}	$V_{CM} - 100$	—	mV	
Terminal resistor	R_T	—	100	—	Ω	Differential input

【*1】 On-off conditions for supply voltage

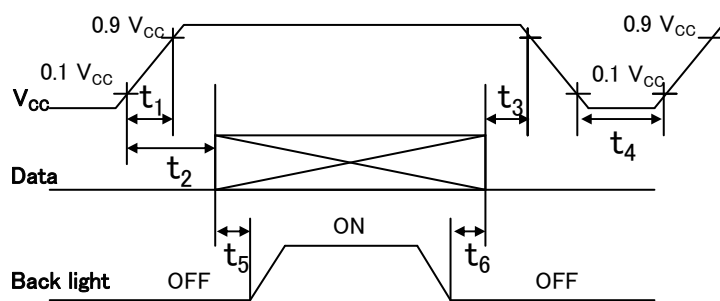

$$0 < t_1 \leq 10\text{ms}$$

$$0 < t_2 \leq 100\text{ms}$$

$$0 < t_3 \leq 1\text{s}$$

$$1\text{s} \leq t_4$$

$$180\text{ms} \leq t_5$$

$$5\text{ms} \leq t_6$$

V_{CC} -dip conditions

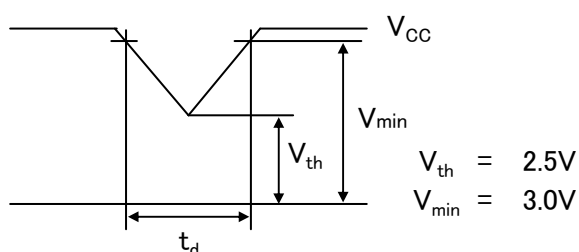

- $V_{th} < V_{CC} \leq V_{min}$
- $t_d \leq 10\text{ms}$
- $V_{CC} < V_{th}$

V_{CC} -dip conditions should also follow the On-off conditions for supply voltage

The relation between the data input and the backlight lighting will recommend the above-mentioned input sequence. When the backlight is turned on before the panel operates, there is a possibility of abnormally displaying. The liquid crystal module is not damaged.

【*2】 Current dissipation

Typical current situation : 253-gray-bar pattern

($V_{CC}=+3.3\text{V}$ 、 $f_{ck} = 33.26\text{MHz}$ 、 $T_a=25^\circ\text{C}$)

【*3】 V_{CM} : Common mode voltage of LVDS driver.

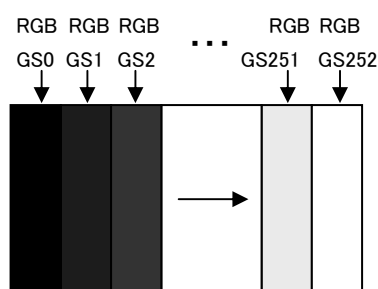

6-2. LED backlight

Ta=+25°C

Parameter	Symbol	Min.	Typ.	Max.	Unit	Remark
LED voltage	V _L	-	22.1	24.0	V	
LED current range	I _L	-	45	60	mA	【*1】
LED power consumption	W _L	-	2.0	-	W	【*2】
Life time (LCD module)	L _L	-	50,000	-	Hour	【*3】【*4】

*LED : CITIZEN ELECTRONICS CO.,LTD

【*1】 Value for one channel

The LED backlight is composed of 2 channels which 7 LED is connected in series.

【*2】 Calculated value for reference ($I_L \times V_L \times 2$ channel)

【*3】 ①Lighting condition:

- Atmosphere temperature : 50°C

- Lighting current : 45mA (Constant current drive / Continuous turning on)

②Definition of Life time:

Brightness becomes 50% of the original value. (under condition ①)

【*4】 In the method of the parallel connection of the input of each channel and the drive, an excessive current flows to the channel side where the voltage is low, and, as a result, there is a possibility of causing the LED longevity decrease.

It is preferable to do the fixed current drive only for each channel to each channel.

7. Timing characteristics of input signals

7-1. Timing characteristics

Parameter	Symbol	Min.	Typ.	Max.	Unit	Remark	
Clock	Frequency	1/Tc	28.0	33.26	36.0	MHz	
ENAB	Horizontal period	TH	1024	1056	1088	clock	【*1】
			28.4	31.7	38.9	μ s	
	Horizontal display period	THd	800	800	800	clock	
	Vertical period	TV	520	525	530	line	
			14.8	16.7	20.6	ms	
Vertical display period	TVd	480	480	480	line		

【*1】 In case of using the long vertical period, the deterioration of display quality, flicker etc. may occur.

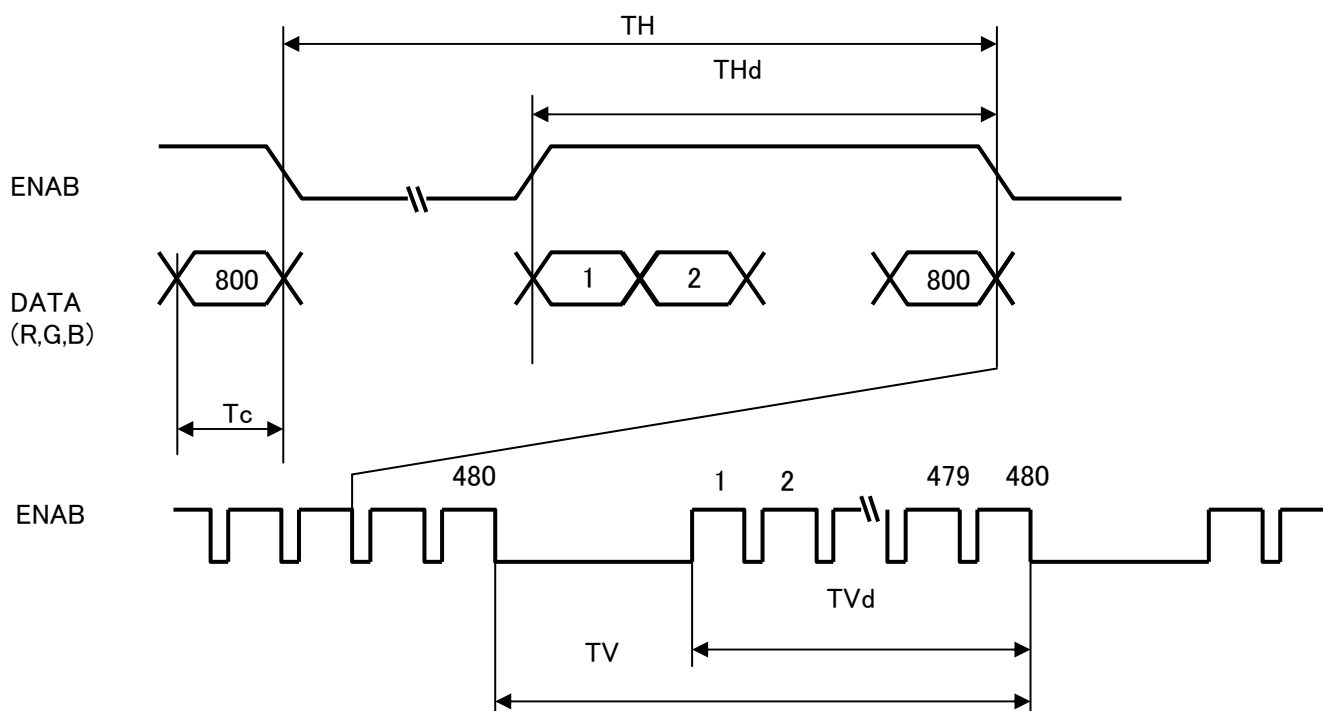

7-2. Input Data Signals and Display Position on the screen

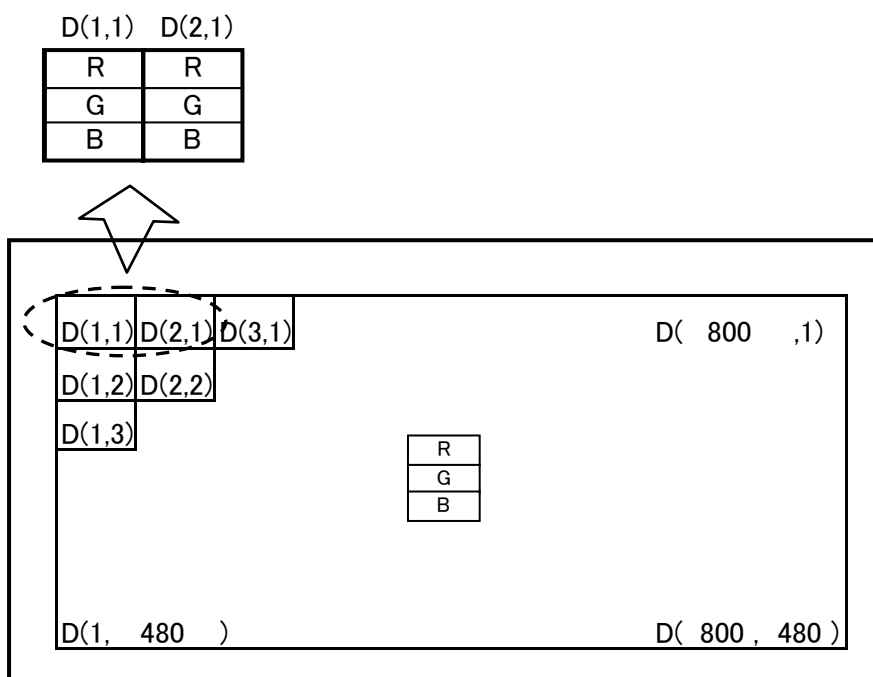

8. Input Signals, Basic Display Colors and Gray Scale of Each Color

Colors & Gray scale	Data signal																							
	Gray Scale	R0	R1	R2	R3	R4	R5	R6	R7	G0	G1	G2	G3	G4	G5	G6	G7	B0	B1	B2	B3	B4	B5	B6
Basic Color	Black	—	0	0	0	0	0	0	0	0	0	0	0	0	0	0	0	0	0	0	0	0	0	0
	Blue	—	0	0	0	0	0	0	0	0	0	0	0	0	0	0	0	X	X	1	1	1	1	1
	Green	—	0	0	0	0	0	0	0	X	X	1	1	1	1	1	1	0	0	0	0	0	0	0
	Cyan	—	0	0	0	0	0	0	0	X	X	1	1	1	1	1	1	X	X	1	1	1	1	1
	Red	—	X	X	1	1	1	1	1	0	0	0	0	0	0	0	0	0	0	0	0	0	0	0
	Magenta	—	X	X	1	1	1	1	1	0	0	0	0	0	0	0	0	X	X	1	1	1	1	1
	Yellow	—	X	X	1	1	1	1	1	X	X	1	1	1	1	1	1	0	0	0	0	0	0	0
	White	—	X	X	1	1	1	1	1	X	X	1	1	1	1	1	1	X	X	1	1	1	1	1
Gray Scale of Red	Black	GS0	0	0	0	0	0	0	0	0	0	0	0	0	0	0	0	0	0	0	0	0	0	
	↑	GS1	1	0	0	0	0	0	0	0	0	0	0	0	0	0	0	0	0	0	0	0	0	
	Darker	GS2	0	1	0	0	0	0	0	0	0	0	0	0	0	0	0	0	0	0	0	0	0	
	↑	↑	↑							↑							↑							
	↓	↓	↓							↓							↓							
	Brighter	GS250	1	0	0	1	1	1	1	0	0	0	0	0	0	0	0	0	0	0	0	0	0	0
	↓	GS251	1	1	0	1	1	1	1	0	0	0	0	0	0	0	0	0	0	0	0	0	0	0
Red	GS252	X	X	1	1	1	1	1	0	0	0	0	0	0	0	0	0	0	0	0	0	0	0	
Gray Scale of Green	Black	GS0	0	0	0	0	0	0	0	0	0	0	0	0	0	0	0	0	0	0	0	0	0	
	↑	GS1	0	0	0	0	0	0	0	1	0	0	0	0	0	0	0	0	0	0	0	0	0	
	Darker	GS2	0	0	0	0	0	0	0	0	1	0	0	0	0	0	0	0	0	0	0	0	0	
	↑	↑	↑							↑							↑							
	↓	↓	↓							↓							↓							
	Brighter	GS250	0	0	0	0	0	0	0	1	0	0	1	1	1	1	1	0	0	0	0	0	0	0
	↓	GS251	0	0	0	0	0	0	0	1	1	0	1	1	1	1	1	0	0	0	0	0	0	0
Green	GS252	0	0	0	0	0	0	0	X	X	1	1	1	1	1	1	0	0	0	0	0	0	0	
Gray Scale of Blue	Black	GS0	0	0	0	0	0	0	0	0	0	0	0	0	0	0	0	0	0	0	0	0	0	
	↑	GS1	0	0	0	0	0	0	0	0	0	0	0	0	0	0	0	1	0	0	0	0	0	
	Darker	GS2	0	0	0	0	0	0	0	0	0	0	0	0	0	0	0	0	1	0	0	0	0	
	↑	↑	↑							↑							↑							
	↓	↓	↓							↓							↓							
	Brighter	GS250	0	0	0	0	0	0	0	0	0	0	0	0	0	0	0	1	0	0	1	1	1	1
	↓	GS251	0	0	0	0	0	0	0	0	0	0	0	0	0	0	0	1	1	0	1	1	1	1
Blue	GS252	0	0	0	0	0	0	0	0	0	0	0	0	0	0	0	X	X	1	1	1	1	1	

0 :Low level voltage 1 :High level voltage X :Don't care

Each basic color can be displayed in 253 gray scales from 8 bit data signals. According to the combination of total 24 bit data signals, the 16-million-color display can be achieved on the screen.

9. Optical Characteristics

$T_a=+25^{\circ}\text{C}$, $V_{cc}=+3.3\text{V}$

Parameter		Symbol	Condition	Min.	Typ.	Max.	Unit	Remark
Viewing angle range	Horizontal	θ_{21}, θ_{22}	$CR > 10$	75	85	-	Deg.	【*1,2,4】
	Vertical	θ_{11}, θ_{12}		75	85	-	Deg.	
Contrast ratio		CR	$\theta = 0^{\circ}$	560	800	-		【*2,4】
Response Time	White Black	$\tau_r + \tau_d$		-	35	-	ms	【*3,4】
Chromaticity of White		W_x		0.26	0.31	0.36		【*4】
		W_y		0.29	0.34	0.39		
Luminance of white		Y_{L1}		280	360	-	cd/m^2	【*4】
White Uniformity			-	-	1.25		【*5】	

※The measurement shall be executed 30 minutes after lighting at rating.

The optical characteristics shall be measured in a dark room or equivalent state with the method shown in Fig.2 below.

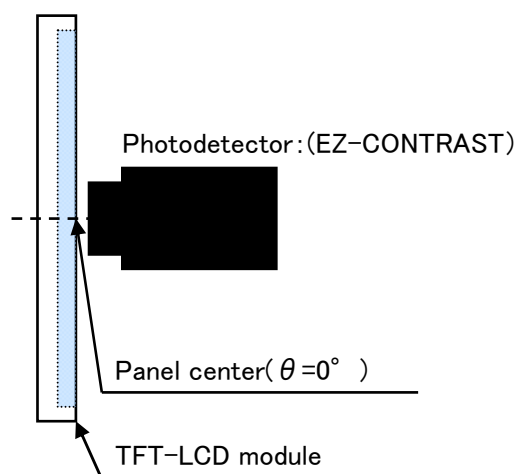

fig.2-1 Measuring method of Viewing angle range.

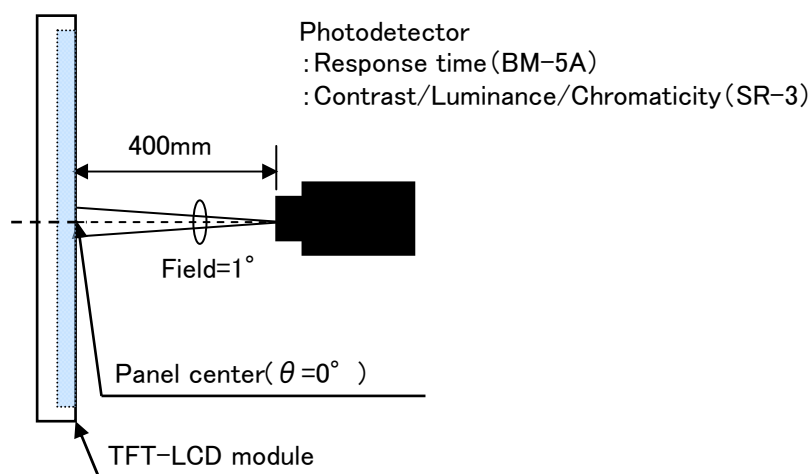
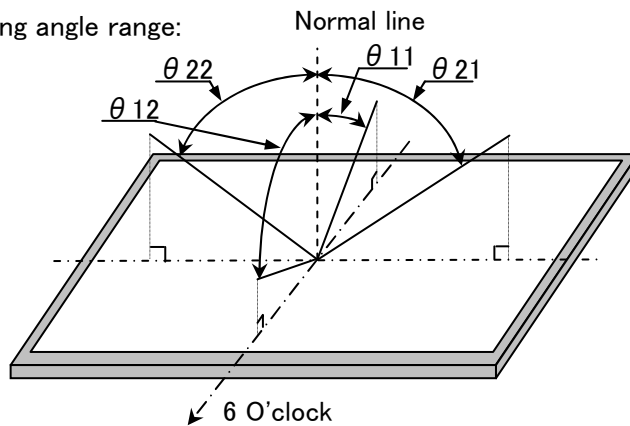

fig.2-2 Measuring method of contrast, luminance, response time, and Chromaticity.

Fig.2 Optical characteristics measurement method

【*1】Definitions of viewing angle range:



【*2】Definition of contrast ratio:

The contrast ratio is defined as the following.
$$\text{Contrast (CR)} = \frac{\text{Luminance with all pixels white}}{\text{Luminance with all pixels black}}$$

【*3】Definition of response time:

The response time is defined as the following figure and shall be measured by switching the input signal for "black" and "white".

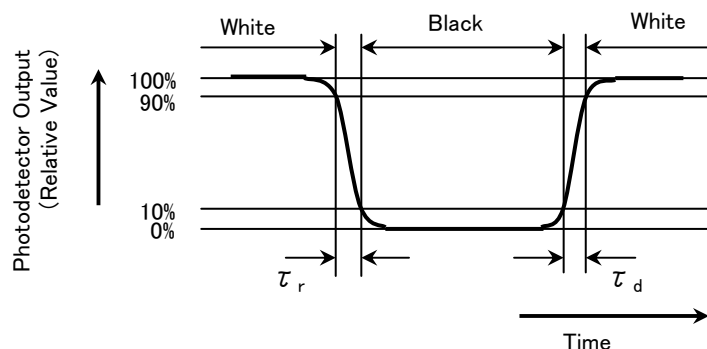

【*4】This shall be measured at center of the screen.

【*5】Definition of white uniformity:

White uniformity is defined as the following with five measurements. (①~⑤)

$$\delta_w = \frac{\text{Maximum luminance of 5 points(①~⑤)}}{\text{Minimum luminance of 5 points(①~⑤)}}$$

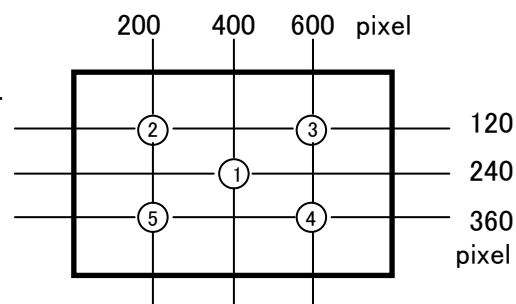

10. Handling Precautions

- a) Be sure to turn off the power supply when inserting or disconnecting the cable.
- b) Be sure to design the cabinet so that the module can be installed without any extra stress such as warp or twist.
- c) Since the front polarizer is easily damaged, pay attention not to scratch it.
- d) Wipe off water drop immediately. Long contact with water may cause discoloration or spots.
- e) When the panel surface is soiled, wipe it with absorbent cotton or other soft cloth.
- f) Since the panel is made of glass, it may break or crack if dropped or bumped on hard surface. Handle with care.
- g) Since CMOS LSI is used in this module, take care of static electricity and injure the human earth when handling. Observe all other precautionary requirements in handling components.
- h) Since there is a circuit board in the module back, stress is not added at the time of a design assembly. Please make it like. If stress is added, there is a possibility that circuit parts may be damaged.
- i) Protection film is attached to the module surface to prevent it from being scratched .
Peel the film off slowly , just before the use, with strict attention to electrostatic charges.
Blow off 'dust' on the polarizer by using an ionized nitrogen.
- j) The polarizer surface on the panel is treated with Anti-Glare for low reflection. In case of attaching protective board over the LCD, be careful about the optical interface fringe etc. which degrades display quality.
- k) It causes an irregular display and the defective indication, etc., when always put constant pressure on the back of the module. Please do not make the structure to press the back of the module.
- l) Do not expose the LCD panel to direct sunlight. Lightproof shade etc. should be attached when LCD panel is used under such environment.
- m) Connect GND to stabilize against EMI and external noise.
- n) When handling LCD modules and assembling them into cabinets, please avoid that long-terms storage in the environment of oxidization or deoxidization gas and the use of such materials as reagent, solvent, adhesive, resin, etc. which generate these gasses, may cause corrosion and discoloration of the modules. Do not use the LCD module under such environment.
- o) Liquid crystal contained in the panel may leak if the LCD is broken. Rinse it as soon as possible if it gets inside your eye or mouth by mistake.
- p) Notice : Never take to pieces the module , because it will cause failure. Please don't remove the fixed tape, insulating tape etc. that was pasted on the original module. (except for protection film of the panel)
- q) Be careful when using it for long time with fixed pattern display as it may cause accidental image. (Please use a screen saver etc., in order to avoid an afterimage.)
- r) If a minute particle enters in the module and adheres to an optical material, it may cause display non-uniformity issue, etc. Therefore, fine-pitch filters have to be installed to cooling and inhalation hole if you intend to install a fan.
- s) An abnormal display by changing in quality of the polarizing plate might occur regardless of contact or no contact to the polarizing plate, because of epoxy resin (amine system curing agent) that comes out from the material and the packaging material used for the set side, the silicon adhesive (dealcoholization system and oxime system), and the tray blowing agents (azo-compound), etc. Please confirm adaptability with your employed material.
- t) Screw hole M2 in the Fig.1 is just the subsidiary for fixing.

11. Packing form

- a) Piling number of cartons : MAX. 7
- b) Package quantity in one carton: 20pcs
- c) Carton size(TYP): 595mm(W) × 265mm(D) × 225mm(H)
- d) Total mass of one carton filled with full modules(20pcs): 6kg

Packing form are shown in Fig 3.

12. Reliability test items

No.	Test item	Conditions	Remark
1	High temperature storage test	Ambient temperature 70°C 240H	【Note1】
2	Low temperature strage test	Ambient temperature -25°C 240H	【Note1】
3	High temperature & high humidity operation test	Ambient temperature 40°C、Humidity 95% RH 240H (No condensation.)	【Note1】
4	High temperature operation test	Panel surface 65°C 240H	【Note1】
5	Low temperature operation test	Ambient temperature -10°C 240H	【Note1】
6	Vibration test (non-operating)	<Sin wave> Frequency : 10~57Hz/Vibration width (one side) : 0.076mm : 57~500Hz/Gravity : 9.8m/s ² Sweep time : 11minutes Test period : 3H(X, Y, Z direction 1H)	【Note1】 【Note2】
7	Shock test (non-operating)	Max. gravity: 490m/s ² Pulse width: 11ms Direction: ±X, ±Y, ±Z Test period : 1time/1direction	【Note1】

【Note1】 Under the display quality test conditions with normal operation state, these shall be no change which may affect practical display function. (normal operation state: Temperature:15~35°C, Humidity:45~75%, Atmospheric pressure:86~106kpa)

【Note2】 The directions of X, Y, Z are defined as below.

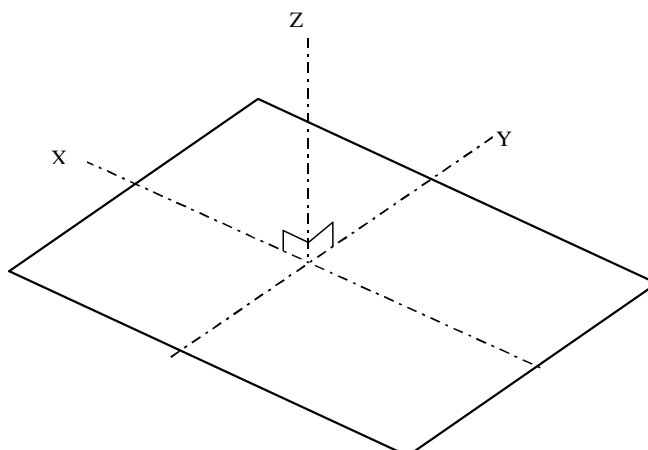

13. Others

13-1. Lot No Label:

Module serial label

The label that displays SHARP·Model No.(LQ070Y3LW01)·Lot No. is stuck on the back of the module.

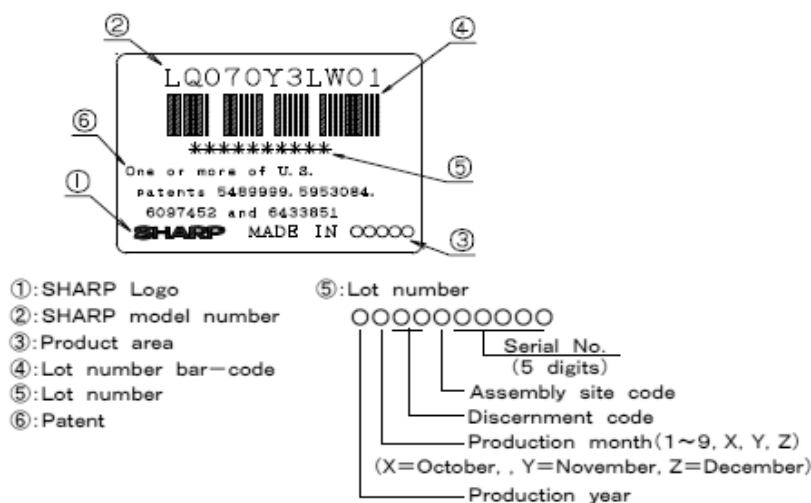

13-2. Packing box Label:

The label that displays ①Model number (LQ070Y3LW01) ②Lot number ③Quantity of module is stuck on the packing box. Moreover, the display of bar code also applies to this.

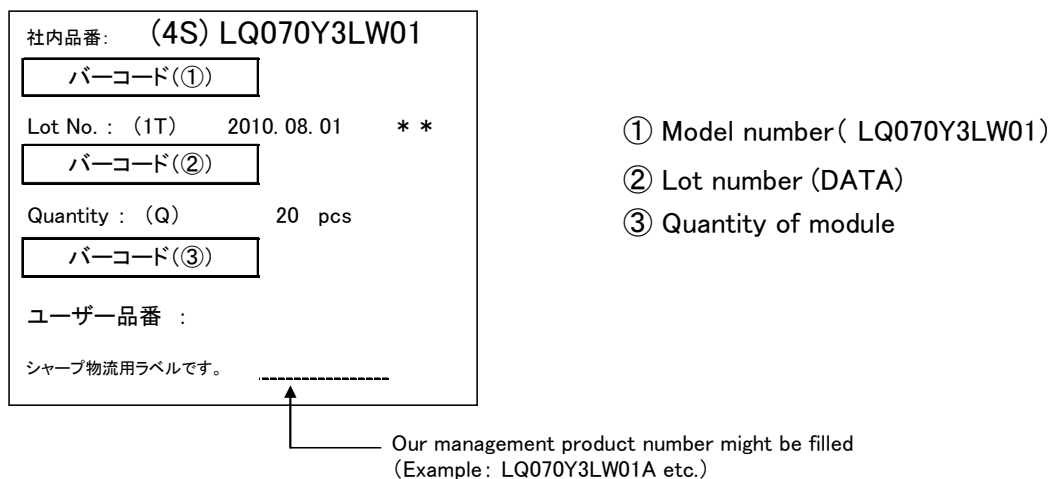

A right picture is written to the packing box of module for the RoHS restriction.

※ R.C.(RoHs Compliance)means these parts have corresponded with the RoHs directive.

This module corresponds from the first sample to RoHS Directive.

R.C.

13-3. The ozone-depleting substances is not used.

13-4. If any problem occurs in relation to the description of this specification sheet, it shall be resolved through discussion with spirit of cooperation.

14. Storage conditions

Environmental condition range of storage temperature and humidity

Temperature 0 to 40 degrees Celsius

Relative humidity 95% and below

【Note】Please refer below as a mean value of the environmental conditions.

5 to 35 degrees Celsius humidity , 85% and below

Please maintain within 240 hours of accumulated length of storage time, with conditions of 40 degrees Celsius and room humidity of 95%.

Direct sun light

Please keep the product in a dark room or cover the product to protect from direct sun light.

Atmospheric condition

腐食 Please refrain from keeping the product with possible corrosive gas or volatile flux.

Prevention of dew

Please store the product carton either on a wooden pallet or a stand / rack to prevent dew.

Do not place directly on the floor. In addition, to obtain moderate ventilation in between the pallet's top and bottom surfaces, pile the cartons up in a single direction and in order.

Please place the product cartons away from the storage wall.

Storage period

Within above mentioned conditions, maximum storage period should be one year.

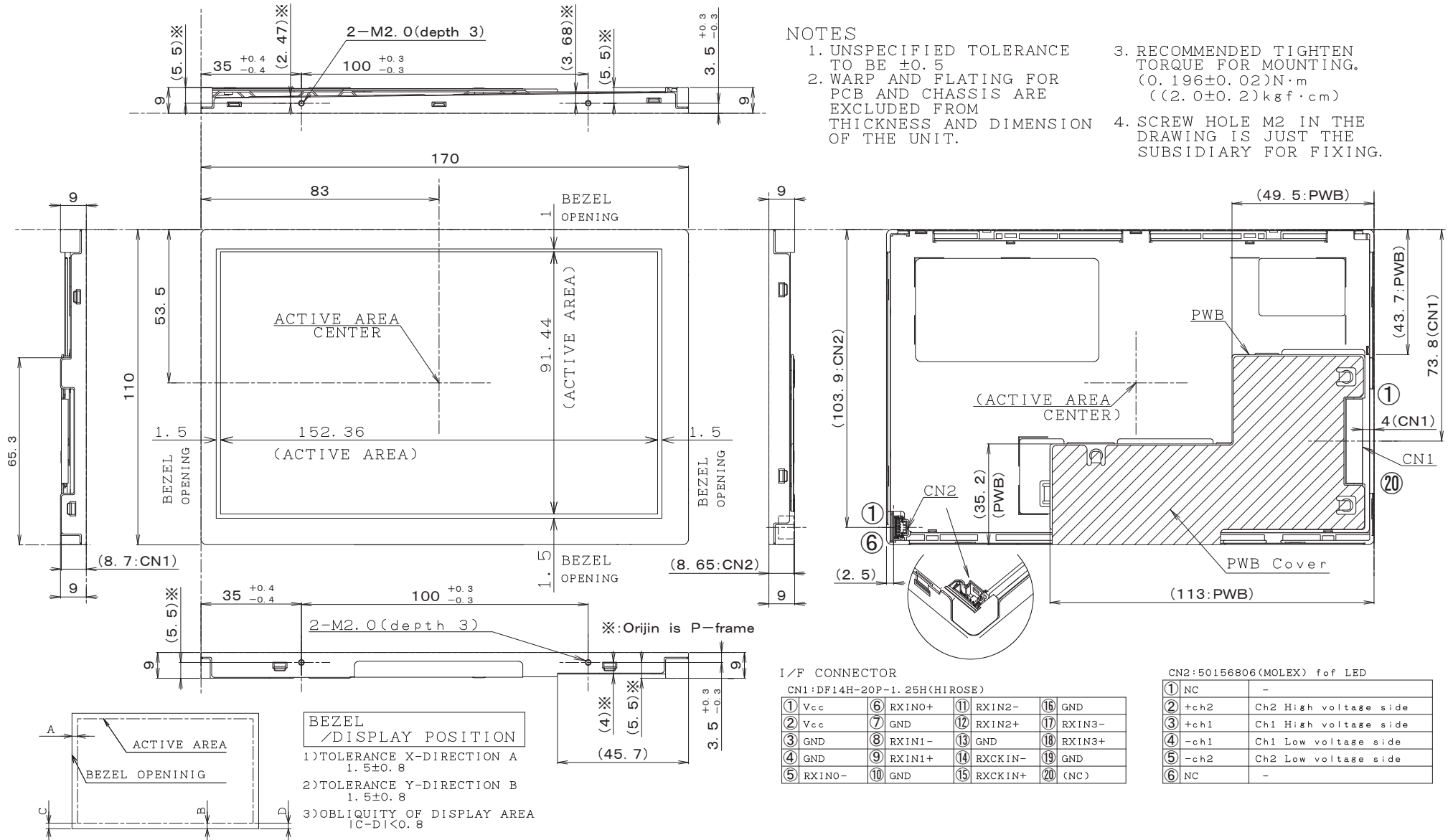

Fig. 1 OUTLINE DIMENSIONS LQ070Y3LW01

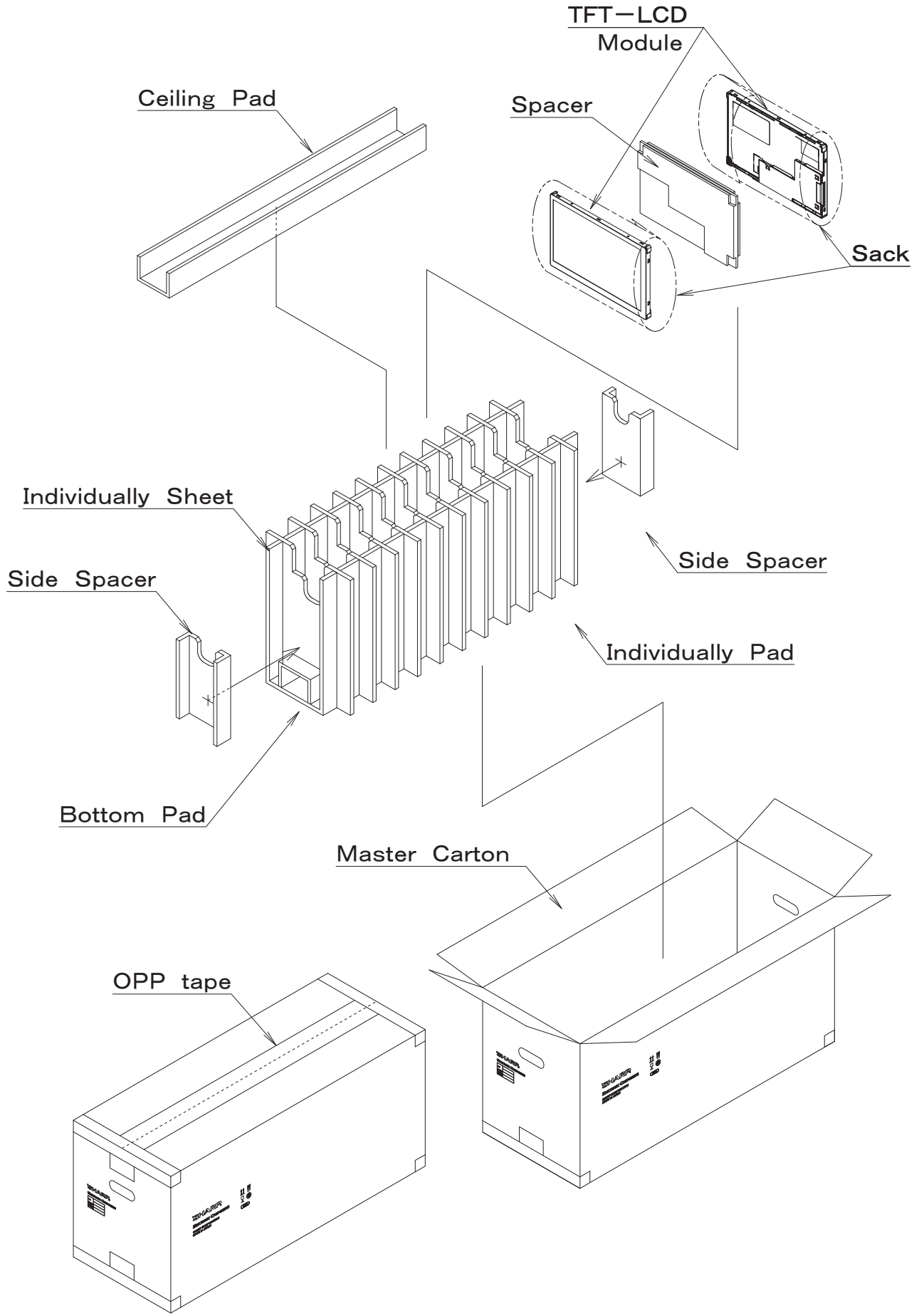

Fig 3. Packing Form

LCD Specification

LCD Group



NORTH AMERICA

Sharp Microelectronics of the Americas
5700 NW Pacific Rim Blvd.
Camas, WA 98607, U.S.A.
Phone: (1) 360-834-8700
Fax: (1) 360-834-8903
www.sharpsma.com

TAIWAN

Sharp Electronic Components
(Taiwan) Corporation
8F-A, No. 16, Sec. 4, Nanking E. Rd.
Taipei, Taiwan, Republic of China
Phone: (886) 2-2577-7341
Fax: (886) 2-2577-7326/2-2577-7328

CHINA

Sharp Microelectronics of China
(Shanghai) Co., Ltd.
28 Xin Jin Qiao Road King Tower 16F
Pudong Shanghai, 201206 P.R. China
Phone: (86) 21-5854-7710/21-5834-6056
Fax: (86) 21-5854-4340/21-5834-6057
Head Office:
No. 360, Bashen Road,
Xin Development Bldg. 22
Waigaoqiao Free Trade Zone Shanghai
200131 P.R. China
Email: smc@china.global.sharp.co.jp

EUROPE

Sharp Microelectronics Europe
Division of Sharp Electronics (Europe) GmbH
Sonninstrasse 3
20097 Hamburg, Germany
Phone: 49 (0)180 507 35 07
Fax: (49) 40-2376-2232
www.sharpsme.com

SINGAPORE

Sharp Electronics (Singapore) PTE., Ltd.
438A, Alexandra Road, #05-01/02
Alexandra Technopark,
Singapore 119967
Phone: (65) 271-3566
Fax: (65) 271-3855

KOREA

Sharp Electronic Components
(Korea) Corporation
RM 501 Geosung B/D, 541
Dohwa-dong, Mapo-ku
Seoul 121-701, Korea
Phone: (82) 2-711-5813 ~ 8
Fax: (82) 2-711-5819

JAPAN

Sharp Corporation
Electronic Components & Devices
22-22 Nagaïke-cho, Abeno-Ku
Osaka 545-8522, Japan
Phone: (81) 6-6621-1221
Fax: (81) 6117-725300/6117-725301
www.sharp-world.com

HONG KONG

Sharp-Roxy (Hong Kong) Ltd.
Level 26, Tower 1, Kowloon Commerce Centre,
No. 51, Kwai Cheong Road, Kwai Chung,
New Territories, Hong Kong
Phone: (852) 28229311
Fax: (852) 28660779
www.sharp.com.hk
Shenzhen Representative Office:
Room 602-603, 6/F,
International Chamber of Commerce Tower,
168 Fuhua Rd. 3, CBD,
Futian District, Shenzhen 518048,
Guangdong, P.R. China
Phone: (86) 755-88313505
Fax: (86) 755-88313515

SPECIFICATIONS ARE SUBJECT TO CHANGE WITHOUT NOTICE.

Suggested applications (if any) are for standard use; See Important Restrictions for limitations on special applications. See Limited Warranty for SHARP's product warranty.

The Limited Warranty is in lieu, and exclusive of, all other warranties, express or implied.

ALL EXPRESS AND IMPLIED WARRANTIES, INCLUDING THE WARRANTIES OF MERCHANTABILITY, FITNESS FOR USE AND FITNESS FOR A PARTICULAR PURPOSE, ARE SPECIFICALLY EXCLUDED. In no event will SHARP be liable, or responsible in any way, for any incidental or consequential economic or property damage.