



MODEL NO. : TM121SDS01

ISSUED DATE: 2012/05/06

VERSION : 1.4

- Preliminary Specification
- Final Product Specification

Customer : _____

Approved by	Notes

SHANGHAI AVIC Confirmed :

Prepared by	Checked by	Approved by
Pean Wu	/	Hyman Chen

This technical specification is subjected to change without notice

The information contained herein is the exclusive property of SHANGHAI AVIC OPTOELECTRONICS Corporation, and shall not be distributed, reproduced, or disclosed in whole or in part without prior written permission of SHANGHAI AVIC OPTOELECTRONICS Corporation.



TABLE OF CONTENTS

1 OUTLINE.....	4
2 GENERAL SPECIFICATIONS.....	5
3 ABSOLUTE MAXIMUM RATINGS.....	6
4 BLOCK DIAGRAM.....	7
5 MECHANICAL SPECIFICATIONS.....	8
6 ELECTRICAL CHARACTERISTICS.....	9
7 CONNECTIONS AND FUNCTIONS FOR INTERFACE PINS.....	11
8 DISPLAY COLORS AND INPUT DATA SIGNALS.....	14
9 INTERFACE TIMING.....	15
10 OPTICS.....	19
11 MARKINGS.....	22
12 PACKING, TRANSPORTATION AND DELIVERY.....	24
13 PRECAUTIONS.....	26
14 OUTDRAWING.....	29



RECORD OF REVISION

Rev	Issued Date	Description	Editor
1.0	2011-6-16	Preliminary Release	Wei Zhang
1.1	2011-8-22	Change the INTERFACE PINS	Hyman Chen
1.2	2012-1-5	Final Product Specification	Hyman Chen
1.3	2012-2-10	Modify the ABSOLUTE MAXIMUM RATINGS	Hyman Chen
1.4	2012-5-6	Modify viewing angle	Pean Wu

AVIC CONFIDENTIAL



1 OUTLINE

1.1 STRUCTURE AND PRINCIPLE

TM121SDS01 module is composed of the amorphous silicon thin film transistor liquid crystal display (a-Si TFT LCD) panel structure with driver LSIs for driving the TFT (Thin Film Transistor) array and a backlight. The a-Si TFT LCD panel structure is injected liquid crystal material into a narrow gap between the TFT array glass substrate and a color-filter glass substrate.

Color (Red, Green, Blue) data signals from a host system (e.g. PC, signal generator, etc.) are modulated into best form for active matrix system by a signal processing board, and sent to the driver LSIs which drive the individual TFT arrays. The TFT array as an electro-optical switch regulates the amount of transmitted light from the backlight assembly, when it is controlled by data signals. Color images are created by regulating the amount of transmitted light through the TFT array of red, green and blue dots.

1.2 APPLICATIONS

- Monitor for industrial display

1.3 FEATURES

- a-Si TFT active matrix
- LVDS interface
- R.G.B input 8bit, 16.2 millions colors (6bit+FRC)
- R.G.B input 6bit selectable, 262K colors
- Resolution SVGA (800× 600 pixels)
- Wide viewing angle 80°/80°/65°/75° (L/R/U/D)
- Contrast ratio 700 :1
- Module size 279.0 (H) ×209.0 (V) ×9.0 (D) mm
- Fast response time (Ton+ Toff= 35 ms)
- Color gamut (55%)
- Edge light type backlight (White-LED)
- LED drive included
- RoHS compliance



2 GENERAL SPECIFICATIONS

Display area	246.0 (H) × 184.5 (V) mm (typ.)
Diagonal size of display	30.7 cm (12.1 inches)
Drive system	a-Si TFT active matrix
Display color	16.2 M color (6bit+FRC), and 262K color selectable
Pixel	800 (H) × 600(V) pixels
Pixel arrangement	RGB vertical stripe
Pixel pitch	0.3075 (H) × 0.3075 (V) mm
Module size	279.0 (H) × 209.0 (V) × 9.0 (D) mm
Contrast ratio	700 :1 (typ.)
Viewing angle(L/R/U/D)	80°/ 80°/ 65°/ 75° (typ.)
Color gamut	55 % (typ.)
Response time	35 ms (typ.)
Luminance	450 cd/m ² (typ.)
Transmissive mode	Normally White
Surface Treatment	Anti Glare
Signal system	LVDS 1port
Power supply voltage	LCD panel signal processing board: 3.3V
Backlight	White-LED
Power consumption	6.8 W (typ)



3 ABSOLUTE MAXIMUM RATINGS

Parameter	Symbol	Rating	Unit	Remarks
Power Supply Voltage	VDD	-0.3 ~ +3.6	V	Ta = 25°C
Input voltage for signals	Vi	-0.3 ~ +3.6 and Vi < VDD + 0.3	V	Ta = 25°C
Light bar peak forward current	I _F	≤ 150	mArms	Note 3
Storage temperature	T _{st}	-30 ~ +80	°C	Note 4
Operating temperature	T _{op}	-20 ~ +70	°C	Note 4, 5
Absolute humidity	AH	≤ 70	g/m ³	Ta > 50°C
Operating altitude	-	≤ 4,850	m	-20°C ≤ Ta ≤ 70°C
Storage altitude	-	≤ 13,600	m	-30°C ≤ Ta ≤ 80°C

Note1: Display signals are DA0+/-, DA1+/-, DA2+/-, DA3+/-, CKA+/-, DB0+/-, DB1+/-, DB2+/-, DB3+/-, and CKB+/-.

Note2: Function signal is MSL.

Note3: Temperature and relative humidity range is shown in the figure below.

- (a) 90%RH Max. (Ta ≤ 40°C)
- (b) Wet-bulb temperature should be 39°C Max. (Ta > 40°C)
- (c) No condensation.

Note4: The temperature of panel display surface area should be -20°C Min and 80°C Max.

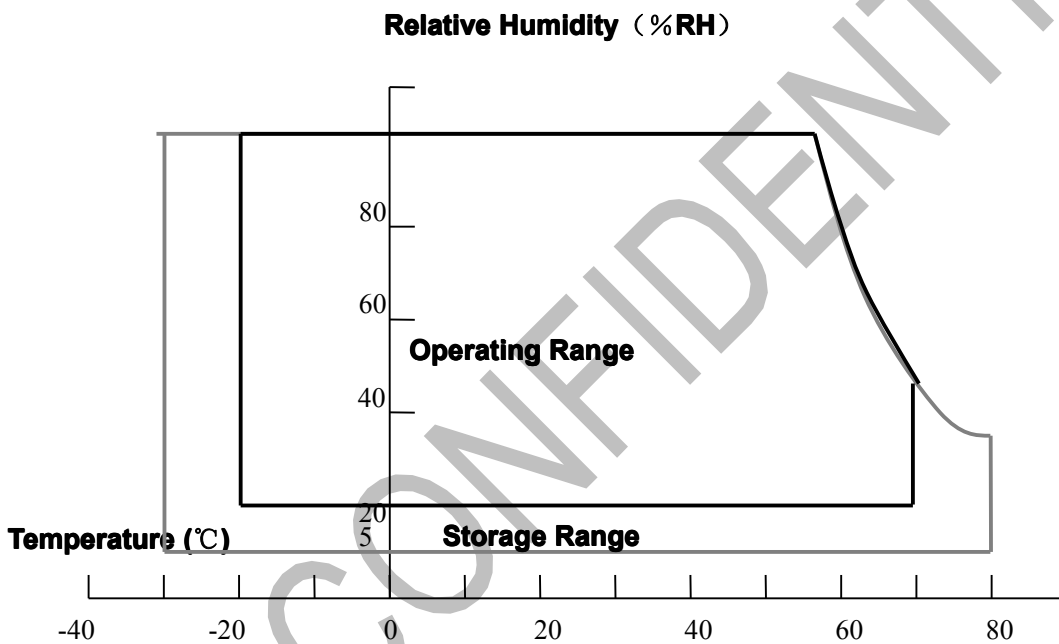



4 BLOCK DIAGRAM

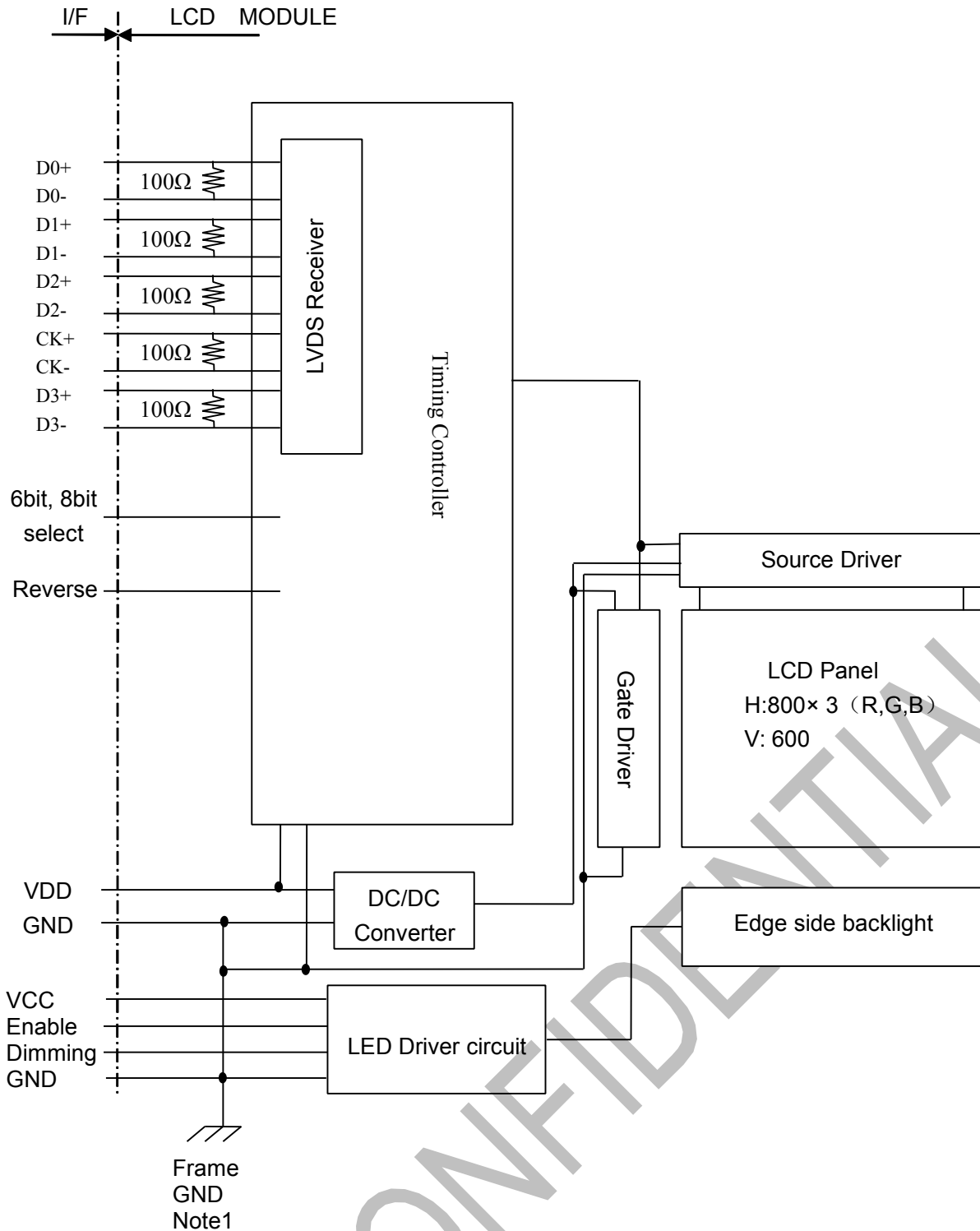

Note1: System ground (GND), Frame ground in the product should be connected together in customer equipment.



5 MECHANICAL SPECIFICATIONS

Parameter	Specification	Unit
Module size	279.0± 0.5 (W) × 209.0 ± 0.5 (H) × 9.0(D)	mm
Display area	246.0(H) × 184.5(V) mm (typ.), [Diagonal 307.5 mm (12.1 inches)]	mm
Weight	425	g

AVIC CONFIDENTIAL



6 ELECTRICAL CHARACTERISTICS

6.1 DRIVING FOR LCD

Parameter	Symbol	min.	typ.	max.	Unit	Remarks
Power supply voltage	VDD	3.0	3.3	3.6	V	-
Power supply current	IDD	-	270	325	mA	at VDD = 3.3V Note 1
Permissible ripple voltage	VRP	-	-	100	mV	VDD
Differential input voltage	Vid	250		450	mV	
Differential input threshold voltage for LVDS receiver	Low	VTL	-100	-	mV	VCM = 1.25V Note2
	High	VTH	-	-	100	
Input voltage width for LVDS receiver	Vi	0	-	2.4	V	-
LVDS Terminating resistor	RT	-	100	-	Ω	-
Rush current	I _{rush}	-	-	1.5	A	Note3

Note 1: All black pattern

Note 2: Common mode voltage for LVDS receiver

Note 3: Measurement Conditions:

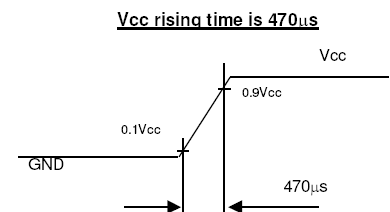
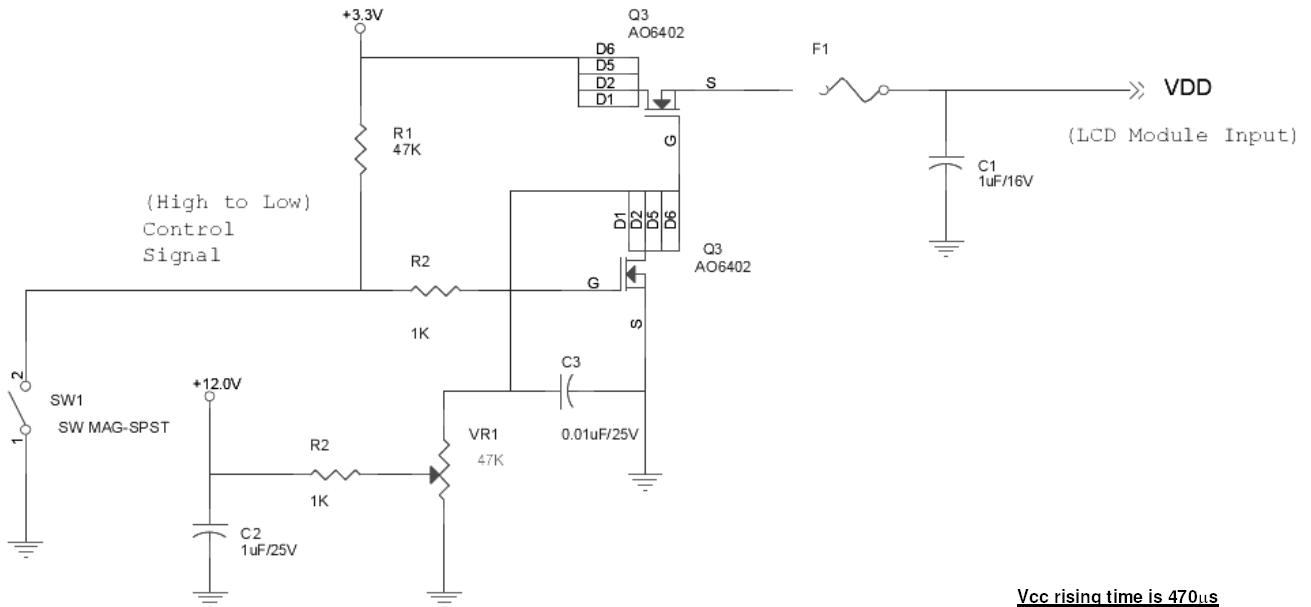

**6.2 DRIVING FOR BACKLIGHT**

(Ta=25°C) Note1

Parameter	Symbol	min.	typ.	max.	Unit	Remarks
Light bar operation voltage (for reference)	V _{LED}	25	-	33	Vrms	Operating with fixed driving current
Light bar operation current (pin)	I _{LED}	-	80	-	mArms	Note1
Light bar operating lifetime	Hr	50000	-	-	Hour	I _{LED} =80mA,Note3

Note1: The backlight of this product is made up of 1 light bar, LED to be 3020, 20pieces, 10 serials and 2 parallels.

Note2: The light bar can work normally if the PWM dimming ratio range is from 0% to 100% and the operation current is 80mA.

Note3: The operating lifetime is mean time to half-luminance. In case the product works under room temperature environment.

AVIC CONFIDENTIAL



7 CONNECTIONS AND FUNCTIONS FOR INTERFACE PINS

7.1 LVDS

CN1: MSB240420HE (Produced by STM) or equivalent.

Pin	Name	Description
1	VDD	3.3V Power Supply
2	VDD	3.3V Power Supply
3	GND	Ground
4	6-8Bit SEL	Select 6 or 8 Bits LVDS Input (VCC:8Bits ; GND/NC: 6Bits)
5	RIN0-	Negative(-) LVDS differential data input
6	RIN0+	Positive(+) LVDS differential data input
7	GND	Ground
8	RIN1-	Negative(-) LVDS differential data input
9	RIN1+	Positive(+) LVDS differential data input
10	GND	Ground
11	RIN2-	Negative(-) LVDS differential data input
12	RIN2+	Positive(+) LVDS differential data input
13	GND	Ground
14	CLKIN-	Clock Signal(-)
15	CLKIN+	Clock Signal(+)
16	GND	Ground
17	RIN3-	Negative(-) LVDS differential data input (Used for 8Bits LVDS Input; NC for 6Bits)
18	RIN3+	Positive(+) LVDS differential data input (Used for 8Bits LVDS Input; NC for 6Bits)
19	REVERSE	Display Reversed Function (VCC: Display Reverse; GND/NC: Normal Display)
20	NC/GND	Test Function Pin(Do not set this pin to High)



7.2 BACKLIGHT

CN2: MSB24038P5 (Produced by STM) or equivalent.

Pin	Symbol	Signal Name
1	VCC	12V
2	GND	GND
3	Enable	5V-On / 0V-Off
4	Dimming	PWM Dimming
5	NC	NC

PWM Dimming:

Parameter		Symbol	min.	typ.	max.	Unit
PWM Input Threshold Voltage	Logic-High	V_{PWMH}	1.2	-	-	V
	Logic-Low	V_{PWML}	-	-	0.4	V
PWM Input Frequency		$1/T_{PWM}$	100	200	10K	Hz

7.3 POSITION OF PLUGS AND A SOCKET

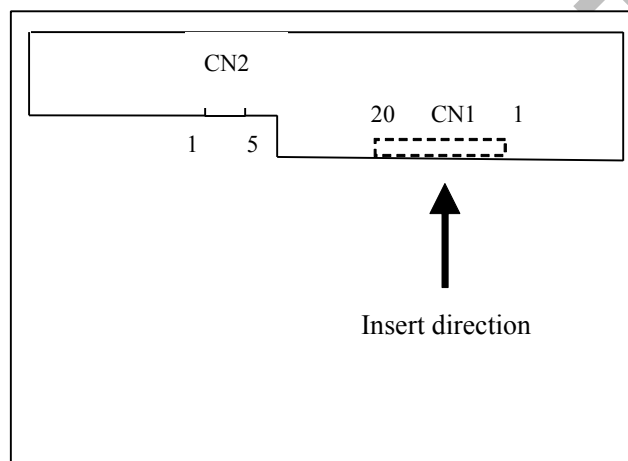



7.4 CONNECTION BETWEEN RECEIVER AND TRANSMITTER FOR LVDS

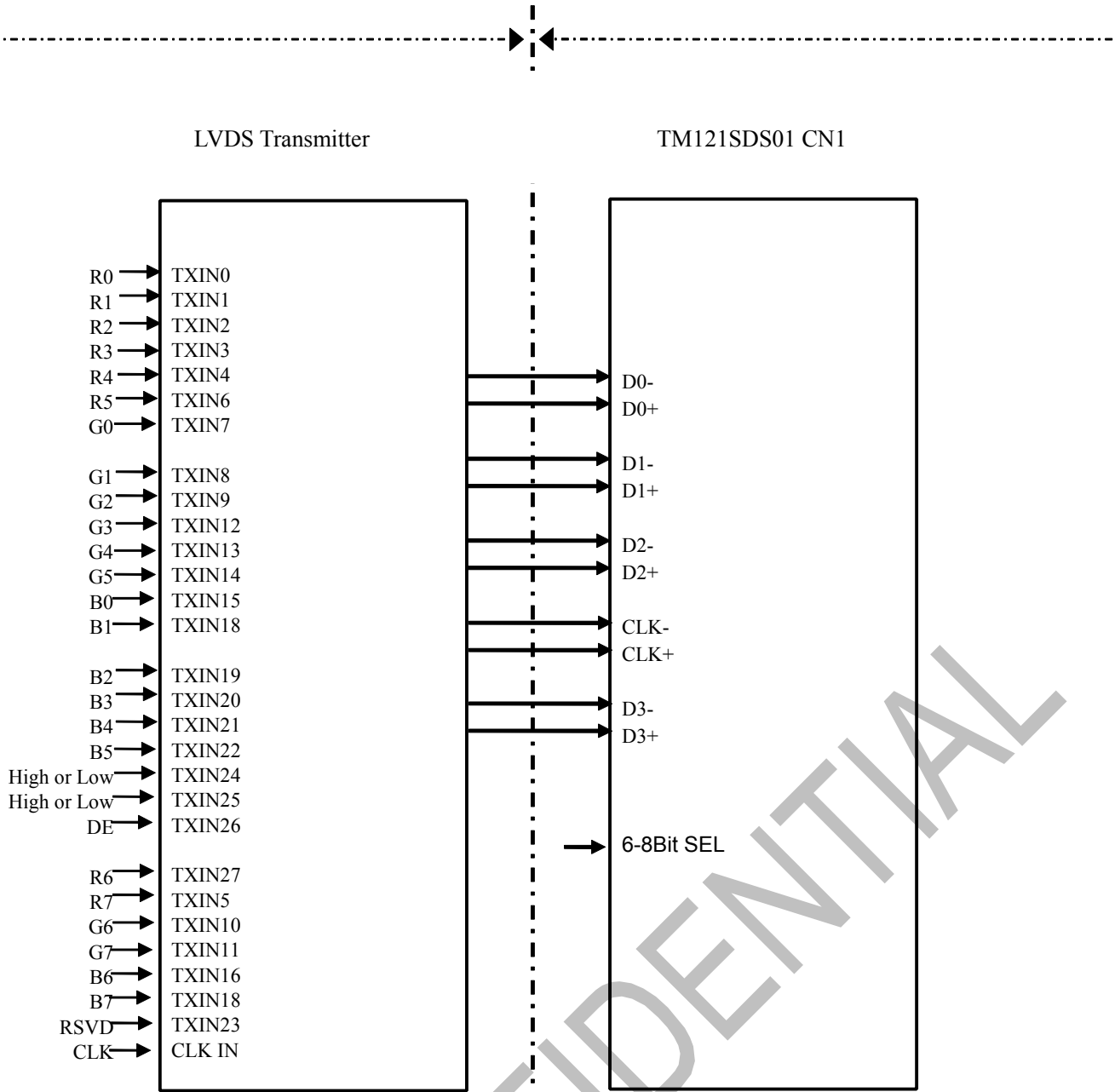

Note1: The lowest bit (R0, G0, B0), the upper bit (R7, G7, B7)

Note2: Connecting cable between LCD panel's connector and transmitter should use 100Ω twisted line.

Note3: If only Hsync and Vsync, the product don't work. Make sure DE signal has been input.



8 DISPLAY COLORS AND INPUT DATA SIGNALS

This product can display in equivalent to 16.2M colors in 256 scales. Also the relation between display colors and input data signals is as the following table.

Display colors		Data signal (0:Low level, 1:High Level)																							
		R7	R6	R5	R4	R3	R2	R1	R0	G7	G6	G5	G4	G3	G2	G1	G0	B7	B6	B5	B4	B3	B2	B1	B0
Basic Color	Black	0	0	0	0	0	0	0	0	0	0	0	0	0	0	0	0	0	0	0	0	0	0	0	0
	Blue	0	0	0	0	0	0	0	0	0	0	0	0	0	0	0	0	1	1	1	1	1	1	1	1
	Red	1	1	1	1	1	1	1	1	0	0	0	0	0	0	0	0	0	0	0	0	0	0	0	0
	Magenta	1	1	1	1	1	1	1	1	0	0	0	0	0	0	0	0	1	1	1	1	1	1	1	1
	Green	0	0	0	0	0	0	0	0	1	1	1	1	1	1	1	1	0	0	0	0	0	0	0	0
	Cyan	0	0	0	0	0	0	0	0	1	1	1	1	1	1	1	1	1	1	1	1	1	1	1	1
	Yellow	1	1	1	1	1	1	1	1	1	1	1	1	1	1	1	1	0	0	0	0	0	0	0	0
	White	1	1	1	1	1	1	1	1	1	1	1	1	1	1	1	1	1	1	1	1	1	1	1	1
Red grayscale	Black	0	0	0	0	0	0	0	0	0	0	0	0	0	0	0	0	0	0	0	0	0	0	0	0
		0	0	0	0	0	0	0	1	0	0	0	0	0	0	0	0	0	0	0	0	0	0	0	0
	Dark ↑	0	0	0	0	0	0	1	0	0	0	0	0	0	0	0	0	0	0	0	0	0	0	0	0
	↓	:	:	:	:	:	:	:	:	:	:	:	:	:	:	:	:	:	:	:	:	:	:	:	
	Bright	1	1	1	1	1	1	0	1	0	0	0	0	0	0	0	0	0	0	0	0	0	0	0	0
	Red	1	1	1	1	1	1	1	0	0	0	0	0	0	0	0	0	0	0	0	0	0	0	0	0
	1	1	1	1	1	1	1	1	0	0	0	0	0	0	0	0	0	0	0	0	0	0	0	0	
Green grayscale	Black	0	0	0	0	0	0	0	0	0	0	0	0	0	0	0	0	0	0	0	0	0	0	0	0
		0	0	0	0	0	0	0	0	0	0	0	0	0	0	0	1	0	0	0	0	0	0	0	0
	Dark ↑	0	0	0	0	0	0	0	0	0	0	0	0	0	0	1	0	0	0	0	0	0	0	0	0
	↓	:	:	:	:	:	:	:	:	:	:	:	:	:	:	:	:	:	:	:	:	:	:	:	
	Bright	0	0	0	0	0	0	0	0	1	1	1	1	1	1	0	1	0	0	0	0	0	0	0	0
	Green	0	0	0	0	0	0	0	0	1	1	1	1	1	1	1	0	0	0	0	0	0	0	0	0
	0	0	0	0	0	0	0	0	1	1	1	1	1	1	1	1	0	0	0	0	0	0	0	0	
Blue grayscale	Black	0	0	0	0	0	0	0	0	0	0	0	0	0	0	0	0	0	0	0	0	0	0	0	0
		0	0	0	0	0	0	0	0	0	0	0	0	0	0	0	0	0	0	0	0	0	0	0	1
	Dark ↑	0	0	0	0	0	0	0	0	0	0	0	0	0	0	0	0	0	0	0	0	0	0	1	0
	↓	:	:	:	:	:	:	:	:	:	:	:	:	:	:	:	:	:	:	:	:	:	:	:	
	Bright	0	0	0	0	0	0	0	0	0	0	0	0	0	0	0	0	1	1	1	1	1	1	0	1
	Blue	0	0	0	0	0	0	0	0	0	0	0	0	0	0	0	0	1	1	1	1	1	1	1	0
	0	0	0	0	0	0	0	0	0	0	0	0	0	0	0	0	1	1	1	1	1	1	1	1	



9 INTERFACE TIMING

9.1 TIMING CHARACTERISTICS

Parameter		Symbol	min.	typ.	max.	Unit	Remarks
Clock	Frequency	1/tc	33.16	39.80	49.74	MHz	LVDS transmitter input
		tc	30.16	25.13	20.10	ns	
	Rise time, Fall time	-	Refer to the timing characteristics of LVDS transmitter			ns	Note 1
	Duty	-				-	
Horizontal signals	Cycle	th	14.8	18.0	26.5	μs	55.5kHz(typ.)
			920	1056	1240	CLK	
	Display period	thd	800			CLK	-
Vertical signals	Cycle	tv	13.3	16.67	20	ms	60.0Hz(typ.)
			608	628	650	H	
	Display period	tvd	600			H	-
DE/Data	Setup time	-	Refer to the timing characteristics of LVDS transmitter			ns	Note 1
	Hold time	-				ns	
	Rise time, Fall time	-				ns	

Note1: See the data sheet of LVDS transmitter.



9.2 INPUT SIGNAL TIMING CHART

Horizontal timing

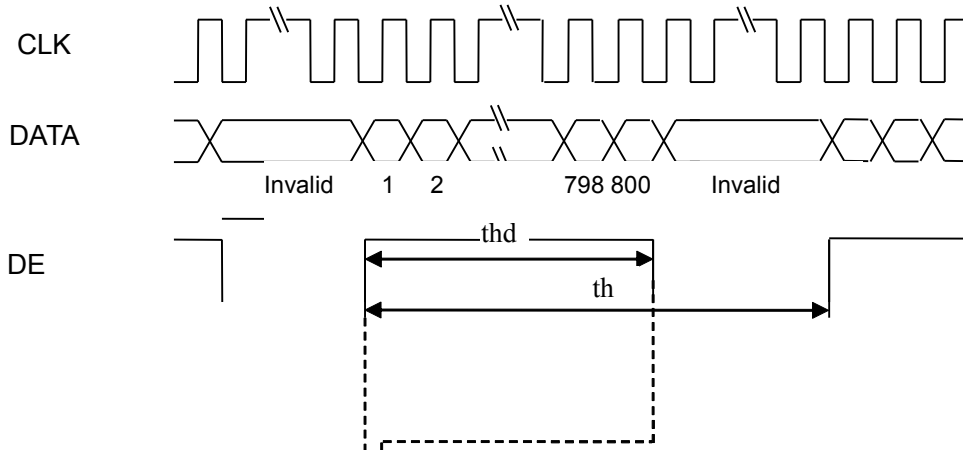

Vertical timing

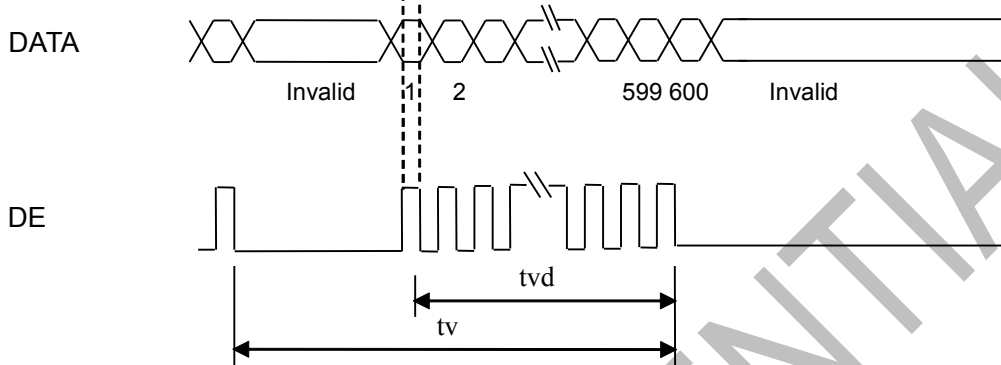



9.3 PIXEL DATA ALIGNMENT OF DISPLAY IMAGE

The following chart is the coordinates of per pixel

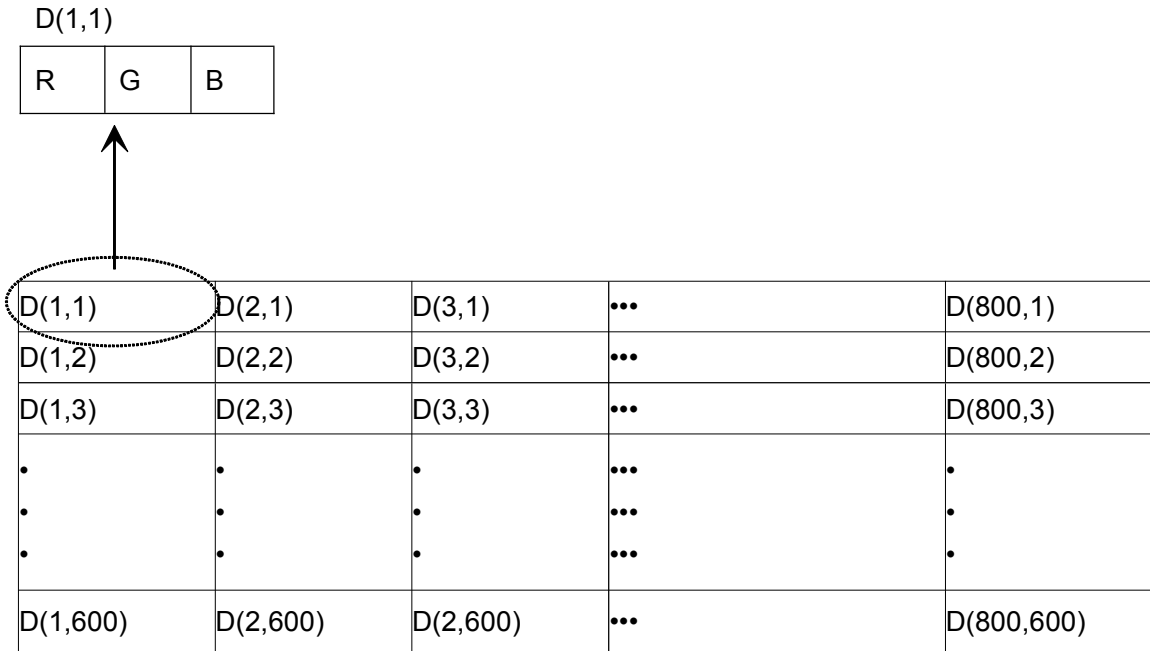

9.4 POWER SUPPLY VOLTAGE SEQUENCE

9.4.1 The sequence of backlight and power

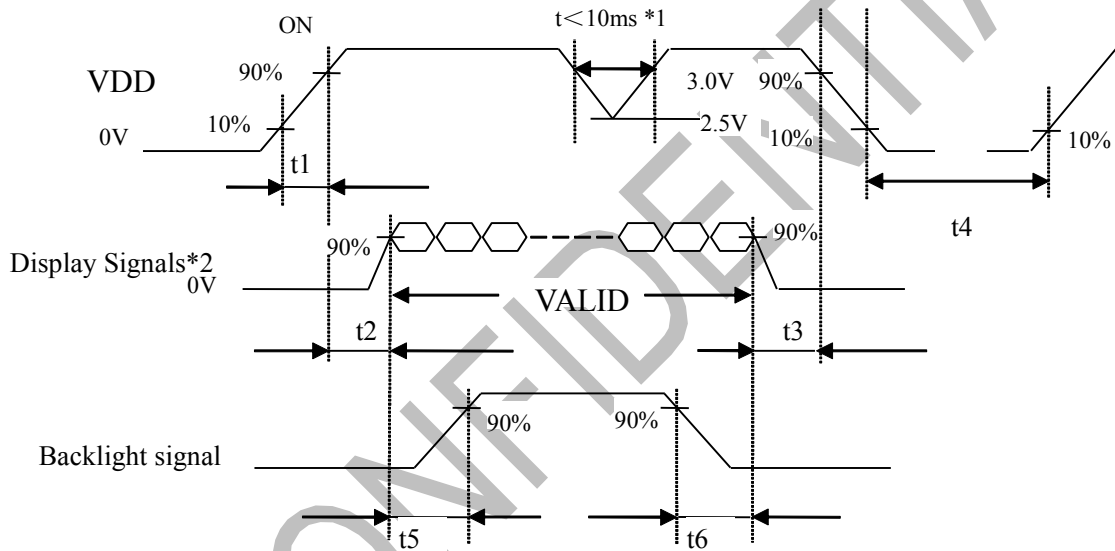

Timing Specifications:

t1 :0.47ms<t1 <10ms;

t2 :0.5 ms<t2 <50ms;



t3 :0ms<t3 <50ms;
 t4 :t4 >1000ms;
 t5 :t5 >200ms;
 t6 :t6 >200ms;

*1. When VDD is on, but the value is lower than 2.5V, a protection circuit may work, then the module may not display.

*2 The signal line is not connected with the module, at the end of cable the terminal resistor of 100Ω should be added.

Note1: Display signals (D0+/-, D1+/-, D2+/-, D3+/- and CK+/-) must be “0” voltage, exclude the VALID period (See above sequence diagram). If these signals are higher than 0.3 V, the internal circuit is damaged.

If some of display signals of this product are cut while this product is working, even if the signal input to it once again, it might not work normally. If customer stops the display signals, they should cut VDD.

Note2: When VDD is on, it should be set above 2.5V.

Note3: The backlight power supply voltage should be inputted within the valid period of display and function signals, in order to avoid unstable data display.

9.4.2 Power supply voltage ripple

When the power supply is designed, the next form can give the reference. If the voltage ripple is over the value in next form, the noise should be seen in display area.

Ripple (Measured at input terminal of power supply)

	VDD (3.3V to drive the panel)
Ripple voltage	≤200mVP-P (Including spike noise)

9.4.3 Fuse

Parameter	Fuse		Rating	Fusing current	Remarks
	Type	Supplier			
VDD	FCC16152ABTP	KAMAYA	1.5A 32V	3.0A	Note1

Note1: There are different power supply systems from the power input terminal. The power supply capacity should be less than the fusing current. If the power supply capacity is above the fusing current, the fuse may blow in a short time, and then nasty smell, smoking and so on may occur.

**10 OPTICS**

10.1 Optical characteristics

Note1 ,Note2

Parameter Note1	Condition	Symbol	min.	typ.	max.	Unit	Remarks	
Luminance	White at center $\theta R=0^\circ, \theta L=0^\circ$ $\theta U=0^\circ, \theta D=0^\circ$	L	400	450	-	cd/m ²	-	
Contrast ratio	White/Black at center $\theta R=0^\circ, \theta L=0^\circ$ $\theta U=0^\circ, \theta D=0^\circ$	CR	500	700	-	-	Note3	
Luminance uniformity	White $\theta R=0^\circ, \theta L=0^\circ$ $\theta U=0^\circ, \theta D=0$	LU	-	1.25	(1.33)	-	Note4	
Chromaticity	White	X coordinate	Wx	0.283	0.313	0.343	-	Note5
		Y coordinate	Wy	0.299	0.329	0.359	-	
	Red	X coordinate	Rx	0.559	0.589	0.619	-	
		Y coordinate	Ry	0.309	0.339	0.369	-	
	Green	X coordinate	Gx	0.298	0.328	0.358	-	
		Y coordinate	Gy	0.562	0.592	0.622	-	
Blue	X coordinate	Bx	0.121	0.151	0.181	-		
	Y coordinate	By	0.065	0.095	0.125	-		
Color gamut	$\theta R=0^\circ, \theta L=0^\circ,$ $\theta U=0^\circ, \theta D=0$ At center, against NTSC	C	50	55	-	%		
Response time	White to black	Ton	-	10	(20)	ms	Note6	
	Black to white	Toff	-	25	(30)	ms	Note7	
	Ton+ Toff	-	-	35	(50)	ms		
Viewing angle	Right	$\theta U=0^\circ, \theta D=0^\circ, CR \geq 10$	θR	70	80	-	°	Note8
	Left	$\theta U=0^\circ, \theta D=0^\circ, CR \geq 10$	θL	70	80	-	°	
	Up	$\theta R=0^\circ, \theta L=0^\circ, CR \geq 10$	θU	55	65	-	°	
	Down	$\theta R=0^\circ, \theta L=0^\circ, CR \geq 10$	θD	65	75	-	°	

Note1: The values in upper table are only initial characteristics.

Note2: Measurement conditions are as follows.

Ta= 25°C, VDD= 3.3V, IBL= 80mA/led, Display mode: VGA,

Horizontal cycle=55.56KHz, Vertical cycle=60.0Hz

Optical characteristics are measured at luminance saturation after 30minutes from working the product in the dark room. Also measurement method for luminance is as follows.

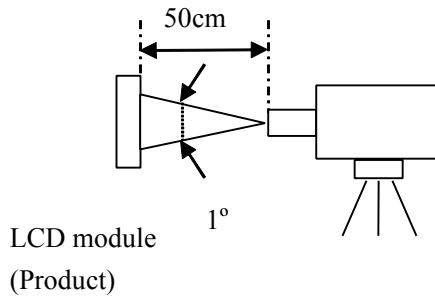

Luminance Meter (TOPCON BM-5A)
Spectroradiometer(TOPCON SR-3)

Note 3: See “10.2 Definition of contrast ratio”.

Note 4: See “10.3 Definition of luminance uniformity”.

Note 5: CIE 1931 Chromaticity Diagram Standard.

Note 6: Product surface temperature: TopF = 33.0 °C

Note 7: See “10.4 Definition of response time”.

Note 8: See “10.5 Definition of viewing angle”.

10.2 Definition of contrast ratio

The contrast ratio is calculated by using the following formula.

$$\text{Contrast ratio (CR)} = \frac{\text{Luminance of white screen}}{\text{Luminance of black screen}}$$

10.3 Definition of luminance uniformity

The luminance uniformity is calculated by using the following formula.

$$\text{Luminance uniformity (LU)} = \frac{\text{Maximum luminance from ① to ⑨}}{\text{Minimum luminance from ① to ⑨}}$$

The luminance is measured at near the 9 points shown below.

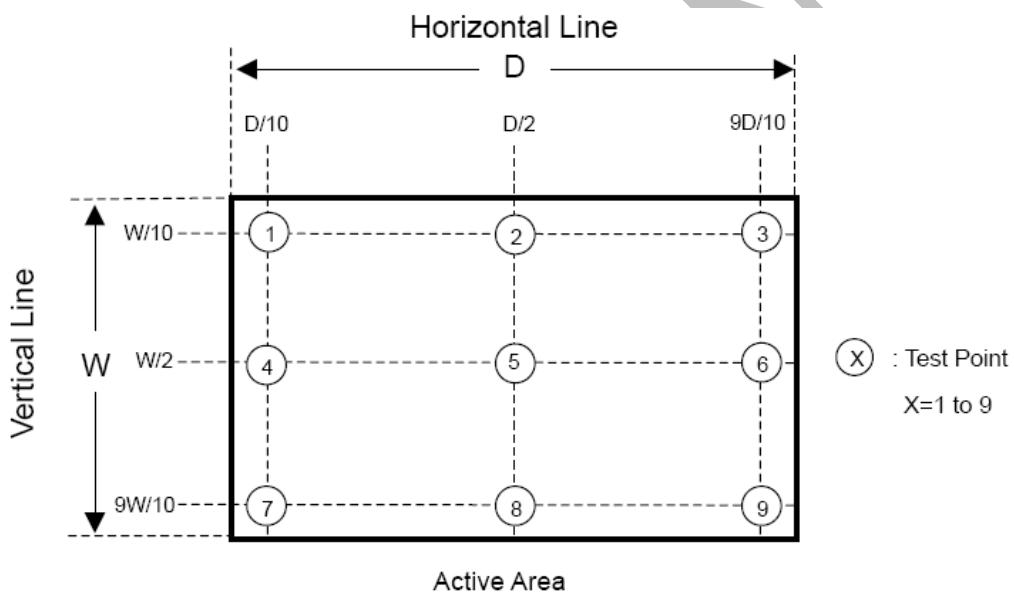



10.4 Definition of response times

Response time is measured, the luminance changes from “white” to “black”, or “black” to “white” on the same screen point, by photo-detector. Ton is the time it takes the luminance change from 90% down to 10%. Also Toff is the time it takes the luminance change from 10% up to 90%. (See the following diagram.)

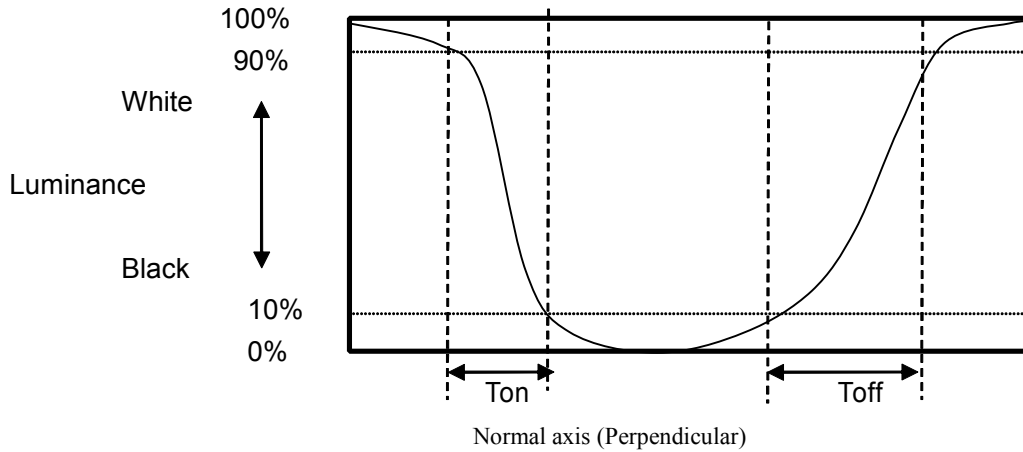

10.5 Definition of viewing angles

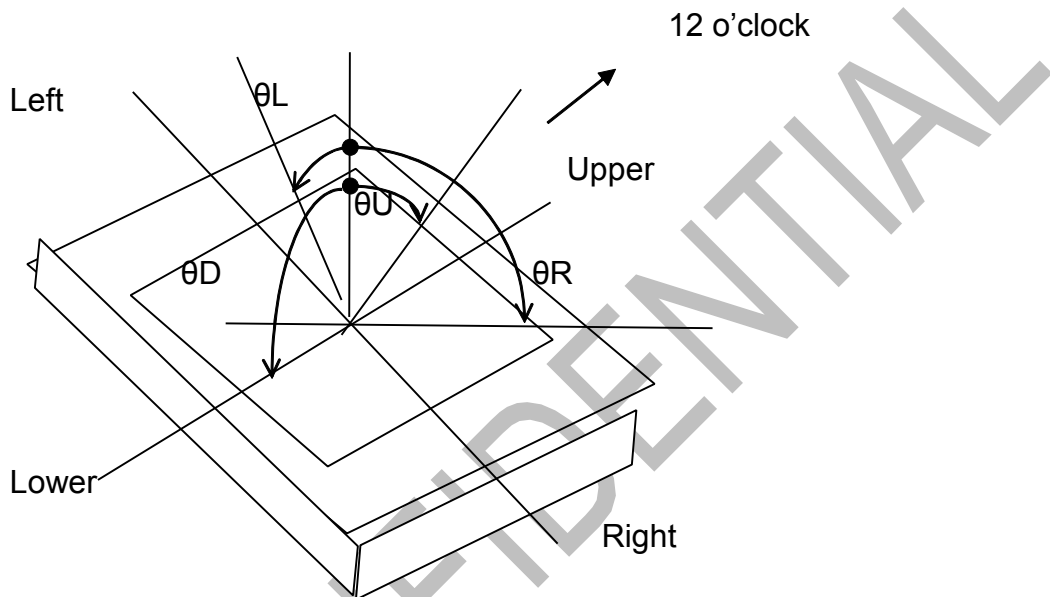



11 MARKINGS

The various markings are attached to this product. See “11.2 INDECATION LOCATIONS” for attachment positions.

11.1 PRODUCT LABEL



Note1: The meaning of OEM number, Example: S190M50A12SA1SA109A0001

<u>S190M50A</u>	<u>12</u>	<u>SA1SA1</u>	<u>09A</u>	<u>0001</u>
Module Number	Source & Gate Driver IC Code	Location Line#	Date code	Serial Number

Date code:

1st Character Year Codes

Month	2010	2011	2012	2013	2014	2015	2016	2017	2018	So on
Code	0	1	2	3	4	5	6	7	8	

2nd Character Month Codes

Month	January	February	March	April	May	June	July	August	September	October	November	December
Code	1	2	3	4	5	6	7	8	9	A	B	C

3rd Character Day Codes

Day	1st	2nd	3rd	4th	5th	6th	7th	8th	9th	10th	11st
Code	1	2	3	4	5	6	7	8	9	A	B
Day	12nd	13rd	14th	15th	16th	17th	18th	19th	20th	21st	22nd
Code	C	D	E	F	G	H	I	J	K	L	M
Day	23rd	24nd	25st	26nd	27rd	28th	29th	30th	31st		
Code	N	O	P	Q	R	S	T	U	V		

Note2: Do not attach anything such as label and so on, on the product label! In case repair the product, AVIC needs the contents of product label such as the lot number, inspection date and so on, to identify the warranty period with individual product. If AVIC cannot decipher the contents of product label, such repair shall be entitled to charge. Also AVIC may give a new lot number to reconditioned products.



11.2 INDICATION LOCATIONS

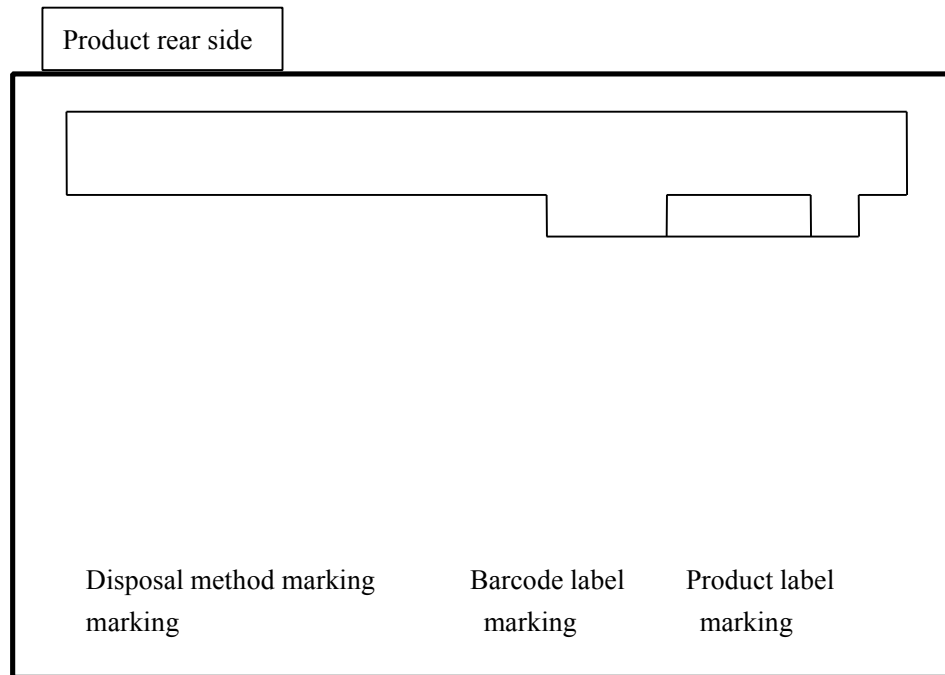



12 PACKING, TRANSPORTATION AND DELIVERY

AVIC will pack products to deliver to customer in accordance with AVIC packing specifications, and will deliver products to customer in such a state that products will not suffer from a damage during transportation .The delivery conditions are as follows.

12.1 PACKING

(1) Packing box

8 products are packed up with the maximum in a packing box(See “12.5 OUTLINE FIGURE FOR PACKING”).

Products are put into a plastic bag for prevention of moisture with cushion, and then the bag is sealed up with heat sealing.

The type name and quality are shown on outside of the packing box, either labeling or printing.

(2) Pallet Packing (See”12.5 OUTLINE FIGURE FOR PACKING “)

- ① Packing boxes are tired on a cardboard pallet.(8 boxes×4 tiers maximum)
- ② Cardboard sleeve and top cap are attached to the packing boxes, then they are fixed by a band.

12.2 INSPECTION RECORD SHEET

Inspection record sheets are included in the packing box with delivery products to customer. It is summarized to a number of products for pass/fail assessment.

12.3 TRANSPORTATION

The product is transported by vehicle, aircraft or shipment in the state of pallet packing.

12.4 SIZE AND WEIGHT FOR PACKING BOX

Parameter	Packing box	Unit
Size	577 (L) ×421 (W) ×326 (H) (typ.)	mm
Weight	0.425 (typ.)	kg
Total weight	13.1 (typ.) (with 20 products)	kg



12.5 OUTLINE FIGURE FOR PACKING

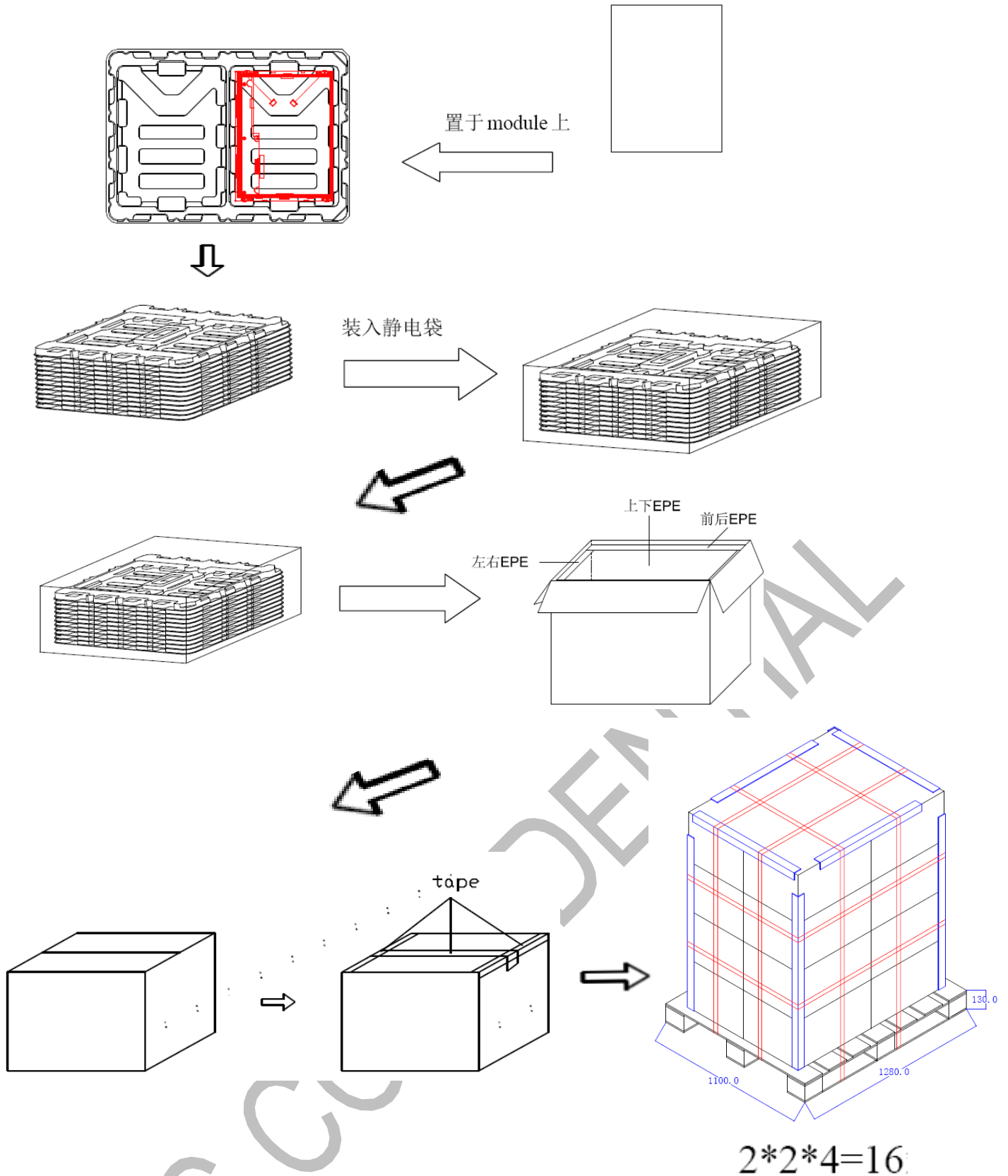



13 PRECAUTIONS

13.1 MEANING OF CAUTION SIGNS

The following caution signs have very important meaning .**Be sure to read “13.2 CAUTIONS” and “13.3 ATTENTIONS”, after understanding these contents!**



This sign have the meaning that customer will be injured by himself or the product will sustain a damage, if customer has wrong operations.



This sign has the meaning that customer will get an electrical shock, if customer has wrong operations.



This sign has the meaning that customer will be injured by himself, if customer has wrong operations.

13.2 CAUTIONS



Do not touch lamp cables while turn on .Customers will be in danger of an electric shock



*** Do not touch the working backlight and IC. Customers will be in danger of burn injury.**
*** Do not shock and press the LCD panel and the backlight! There is a danger of breaking, because they are made of glass.(shock :To be not greater 294m/s² and to be not greater 11ms, Pressure: To be not greater 19.6N)**

13.3 ATTENTIONS



13.3.1 Handling of the product

Take hold of both ends without touch the circuit board when customer pulls out products (LCD modules) from inner packing box. If customer touches it, products may be broken down or out of adjustment, because of stress to mounting parts.

Do not hook cables nor pull connection cables such as flexible cable and so on , for fear of damage.

If customer puts down the product temporarily, the product puts on flat subsoil as a display side turns down.

Take the measures of electrostatic discharge such as earth band, ionic shower and so on, when customer deal with the product, because products may be damaged by electrostatic.

The torque for mounting screws must never exceed 0.34N-m. Higher torque values might result in distortion of the bezel.

The product must be installed using mounting holes without undue stress such as bends or twist (See outline

The information contained herein is the exclusive property of SHANGHAI AVIC OPTOELECTRONICS Corporation, and shall not be distributed, reproduced, or disclosed in whole or in part without prior written permission of SHANGHAI AVIC OPTOELECTRONICS Corporation.



drawings). And do not add undue stress to any portion (such as bezel flat area) except mounting hole portion. Bends or twist described above and undue stress to any portion except mounting hole portion may cause display un-uniformity.

Do not press or rub on the sensitive display surface. If customer clean on the panel surface, AVIC recommends using the cloth with ethanolic liquid such as screen cleaner for LCD.

Do not push-pull the interface connectors while the product is working, because wrong power sequence may break down the product.

Do not bend or unbend the lamp cable at the near part of the lamp holding rubber, to avoid the damage for high voltage side of the lamp. This damage may cause a lamp breaking and abnormal operation of high voltage circuit.

13.3.2 Environment

Do not operate or store in high temperature, high humidity, dewdrop atmosphere or corrosive gases. Keep the product in antistatic pouch in room temperature, because of avoidance for dusts and sunlight, if customer stores the product.

In order to prevent dew condensation occurring by temperature difference, the product packing box must be opened after leave under the environment of an unpacking room temperature enough. Because a situation of dew condensation occurring is changed by the environment temperature and humidity, evaluate the leaving time sufficiently. (Recommendation leaving time: 6 hour or more with packing state)

Do not operate in a high magnetic field. Circuit boards may be broken down by it.

This product is not designed as radiation hardened.

Use an original protection sheet on the product surface (polarizer). Adhesive type protection sheet should be avoided, because it may change color or properties of the polarizer.

13.3.3 Characteristics

The following items are neither defects nor failures.

ambient temperature.

The LCD may be seemed luminance non-uniformity, flicker, vertical seam or small spot by display patterns.

Optical characteristics (e.g. luminance, display uniformity, etc.) gradually is going to change depending on operating time, and especially low temperature, because the LCD has cold cathode fluorescent lamps.

Do not display the fixed pattern for a long time because it may cause image sticking. Use a screen saver, if the fixed pattern is displayed on the screen.

The display color may be changed by viewing angle because of the use of condenser sheet in the backlight.

Optical characteristics may be changed by input signal timings.

The interference noise of input signal frequency for this product and luminance control frequency of customer's backlight inverter may appear on a display. Set up luminance control frequency of backlight inverter so that the interference noise does not appear.

13.4 Other

- ① All GND and VCC terminals should be used without a non-connected line.
- ② Do not disassemble a product or adjust volume without permission of AVIC.

Pay attention not to insert waste materials inside of products, if customer uses screw nails.

The information contained herein is the exclusive property of SHANGHAI AVIC OPTOELECTRONICS Corporation, and shall not be distributed, reproduced, or disclosed in whole or in part without prior written permission of SHANGHAI AVIC OPTOELECTRONICS Corporation.



Pack the product with original shipping package, because of avoidance of some damages during transportation, when customer returns it to AVIC for repair and so on .

Not only the module but also the equipment should be packed and transported as the module. becomes vertical .Otherwise, there is the fear that a display dignity decreases by an impact or vibrations.

AVIC CONFIDENTIAL



14 OUTDRAWING

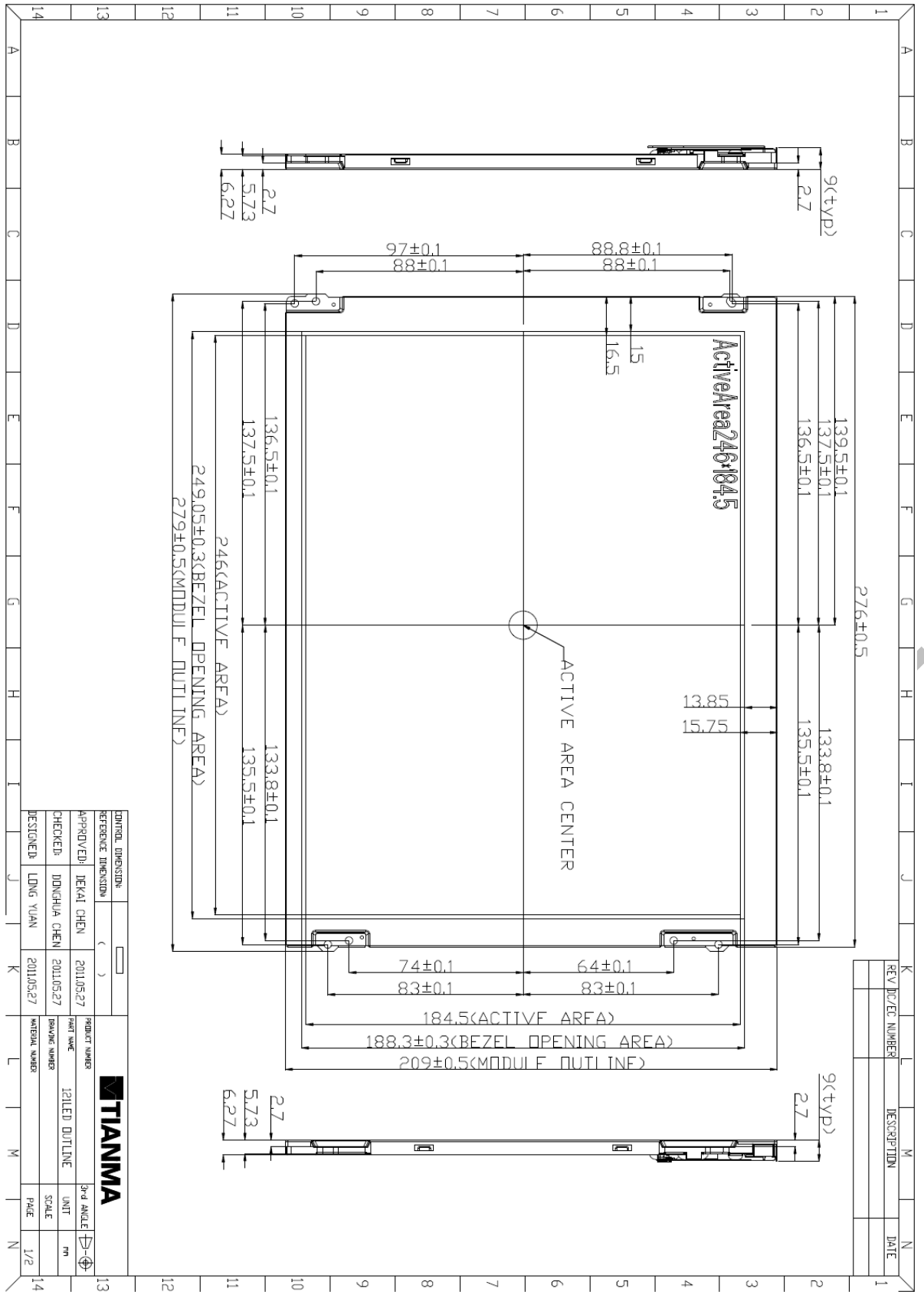

The information contained herein is the exclusive property of SHANGHAI AVIC OPTOELECTRONICS Corporation, and shall not be distributed, reproduced, or disclosed in whole or in part without prior written permission of SHANGHAI AVIC OPTOELECTRONICS Corporation.

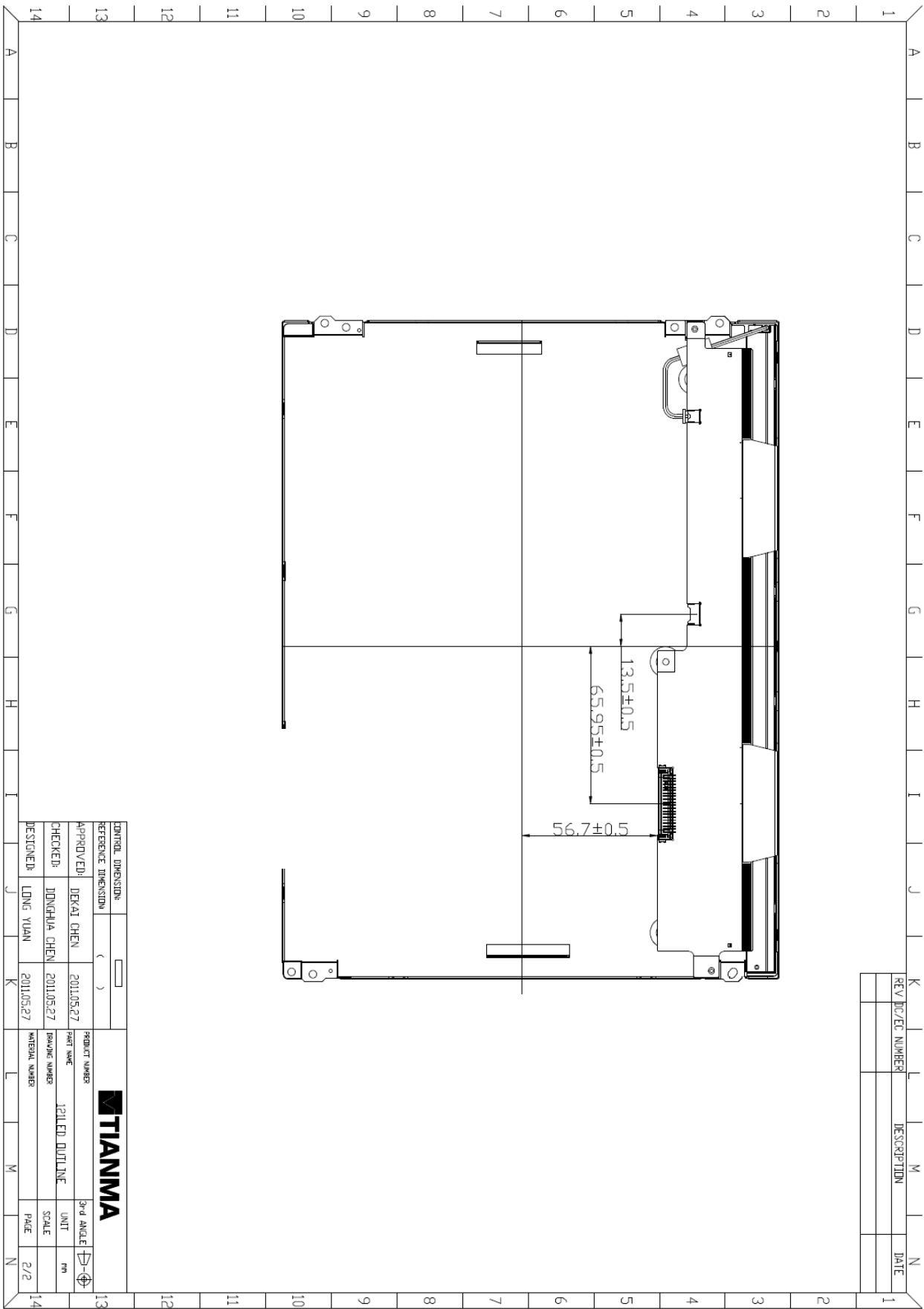

The information contained herein is the exclusive property of SHANGHAI AVIC OPTOELECTRONICS Corporation, and shall not be distributed, reproduced, or disclosed in whole or in part without prior written permission of SHANGHAI AVIC OPTOELECTRONICS Corporation.